

Prüfbericht-Nr.: <i>Test report no.:</i>	CN25J408 002	Auftrags-Nr.: <i>Order no.:</i>	326172903	Seite 1 von 10 <i>Page 1 of 10</i>
Kunden-Referenz-Nr.: <i>Client reference no.:</i>	2367253	Auftragsdatum: <i>Order date:</i>	2026-02-09	
Auftraggeber: <i>Client:</i>	FENECON GmbH Gewerbepark 6, 94547 Iggenbach, Deutschland			
Prüfgegenstand: <i>Test item:</i>	Hybrid Inverter			
Bezeichnung / Typ-Nr.: <i>Identification / Type no.:</i>	FINV-100-1-DAH			
Auftrags-Inhalt: <i>Order content:</i>	A3 Certificate			
Prüfgrundlage: <i>Test specification:</i>	VDE-AR-N 4105/11.18 DIN VDE V 0124-100/06.20			
Wareneingangsdatum: <i>Date of sample receipt:</i>	2026-02-09			
Prüfmuster-Nr.: <i>Test sample no.:</i>	A004207861-001			
Prüfzeitraum: <i>Testing period:</i>	2026-02-09-2026-02-10			
Ort der Prüfung: <i>Place of testing:</i>	TÜV Rheinland (Shanghai) Co., Ltd. No.177, Lane 777 West Guangzhong Road, Jing'an District, Shanghai, China			
Prüflaboratorium: <i>Testing laboratory:</i>	TÜV Rheinland (Shanghai) Co., Ltd.			
Prüfergebnis*: <i>Test result*:</i>	Pass			
geprüft von: tested by: Andy Y.F. Zhang/Alexander Sun	genehmigt von: <i>authorized by:</i> Ruiyang Ding			
Datum: <i>Date:</i> 2026-02-10	Ausstellungsdatum: <i>Issue date:</i> 2026-02-10			
Stellung / Position: Trainee / Project Engineer	Stellung / Position: Authorizer			
Sonstiges / Other:	The test data is originally from test report CN25J408 001. No extra testing is required. The FINV-100-1-DAH is identical to GW100K-ET-G10 of GoodWe Technologies Co., Ltd, except for model name, trademark and license holder. See following pages for details. This report does not evidence compliance of the provided sample with the relevant standards but only with the referred tests. This test report documents the findings of examination conducted on the delivered product mentioned above only. This report does not entitle the applicant to carry any safety mark on this or similar products. Further for sales or other application purposes of the tested product, any reference to TÜV Rheinland or a test through TÜV Rheinland is only permissible with prior written consent of TÜV Rheinland.			
Zustand des Prüfgegenstandes bei Anlieferung: <i>Condition of the test item at delivery:</i>	Prüfmuster vollständig und unbeschädigt <i>Test item complete and undamaged</i>			
* Legende: P(ass) = entspricht o.g. Prüfgrundlage(n) F(ail) = entspricht nicht o.g. Prüfgrundlage(n) N/A = nicht anwendbar N/T = nicht getestet				
* Legend: P(ass) = passed a.m. test specification(s) F(ail) = failed a.m. test specification(s) N/A = not applicable N/T = not tested				
<p>Dieser Prüfbericht bezieht sich nur auf das o.g. Prüfmuster und darf ohne Genehmigung der Prüfstelle nicht auszugsweise vervielfältigt werden. Dieser Bericht berechtigt nicht zur Verwendung eines Prüfzeichens. <i>This test report only relates to the above mentioned test sample. Without permission of the test center this test report is not permitted to be duplicated in extracts. This test report does not entitle to carry any test mark.</i></p>				

Prüfbericht-Nr.: **CN25J408 002**
Test report no.:

Seite 2 von 10
Page 2 of 10

Anmerkungen
Remarks

1	<p>Alle eingesetzten Prüfmittel waren zum angegebenen Prüfzeitraum gemäß eines festgelegten Kalibrierungsprogramms unseres Prüfhauses kalibriert. Sie entsprechen den in den Prüfprogrammen hinterlegten Anforderungen. Die Rückverfolgbarkeit der eingesetzten Prüfmittel ist durch die Einhaltung der Regelungen unseres Managementsystems gegeben. Detaillierte Informationen bezüglich Prüfkonditionen, Prüfequipment und Messunsicherheiten sind im Prüflabor vorhanden und können auf Wunsch bereitgestellt werden.</p> <p><i>The equipment used during the specified testing period was calibrated according to our test laboratory calibration program. The equipment fulfils the requirements included in the relevant standards. The traceability of the test equipment used is ensured by compliance with the regulations of our management system. Detailed information regarding test conditions, equipment and measurement uncertainty is available in the test laboratory and could be provided on request.</i></p>
2	<p>Wie vertraglich vereinbart, wurde dieses Dokument nur digital unterzeichnet. Der TÜV Rheinland hat nicht überprüft, welche rechtlichen oder sonstigen diesbezüglichen Anforderungen für dieses Dokument gelten. Diese Überprüfung liegt in der Verantwortung des Benutzers dieses Dokuments. Auf Verlangen des Kunden kann der TÜV Rheinland die Gültigkeit der digitalen Signatur durch ein gesondertes Dokument bestätigen. Diese Anfrage ist an unseren Vertrieb zu richten. Eine Umweltgebühr für einen solchen zusätzlichen Service wird erhoben. Informationen zur Verifizierung der Authentizität unserer Dokumente erhalten Sie auf folgender Webseite: go.tuv.com/digital-signature</p> <p><i>As contractually agreed, this document has been signed digitally only. TÜV Rheinland has not verified and unable to verify which legal or other pertaining requirements are applicable for this document. Such verification is within the responsibility of the user of this document. Upon request by its client, TÜV Rheinland can confirm the validity of the digital signature by a separate document. Such request shall be addressed to our Sales department. An environmental fee for such additional service will be charged. For information on verifying the authenticity of our documents, please visit the following website: go.tuv.com/digital-signature</i></p>
3	<p>Prüfklausel mit der Note * wurden an qualifizierte Unterauftragnehmer vergeben und sind unter der jeweiligen Prüfklausel des Berichts beschrieben. Abweichungen von Prüfspezifikation(en) oder Kundenanforderungen sind in der jeweiligen Prüfklausel im Bericht aufgeführt.</p> <p><i>Test clauses with remark of * are subcontracted to qualified subcontractors and described under the respective test clause in the report. Deviations of testing specification(s) or customer requirements are listed in specific test clause in the report.</i></p>
4	<p>Die Entscheidungsregel für Konformitätserklärungen basierend auf numerischen Messergebnissen in diesem Prüfbericht basiert auf der "Null-Grenzwert-Regel" und der "Einfachen Akzeptanz" gemäß ILAC G8:2019 und IEC Guide 115:2021, es sei denn, in der auf Seite 1 dieses Berichts genannten angewandten Norm ist etwas anderes festgelegt oder vom Kunden gewünscht. Dies bedeutet, dass die Messunsicherheit nicht berücksichtigt wird und daher auch nicht im Prüfbericht angegeben wird. Zu weiteren Informationen bezüglich des Risikos durch diese Entscheidungsregel siehe ILAC G8:2019.</p> <p><i>The decision rule for statements of conformity, based on numerical measurement results, in this test report is based on the "Zero Guard Band Rule" and "Simple Acceptance" in accordance with ILAC G8:2019 and IEC Guide 115:2021, unless otherwise specified in the applied standard mentioned on Page 1 of this report or requested by the customer. This means that measurement uncertainty is not taken in account and hence also not declared in the test report. For additional information to the resulting risk based of this decision rule please refer to ILAC G8:2019.</i></p>



Prüfbericht-Nr.: CN25J408 002
Test Report No.:

Seite 3 von 10
Page 3 of 10

Produktbeschreibung
Product description

Copy of marking plate:

The artwork below may be only a draft. The use of certification marks on a product must be authorized by the respective NCBs that own these marks.

	
Product	PV-Bat-Inverter
Model	FINW-100-1-DAH
PV	
Max. Input Voltage	1000Vd.c.
MPPT Operating Voltage Range	160...950Vd.c.
Max. MPPT Current	42Ad.c.*8
Max. MPPT Short Circuit Current	55Ad.c.*8
Battery	
Battery Voltage Range	300...800Vd.c.
Max. Continuous Charging Current	110Ad.c.*2
Max. Continuous Discharging Current	110Ad.c.*2
Battery Type	LFP(LiFePO ₄)
On-grid	
Nominal Voltage	220/380, 230/400, 240/415Va.c.,3L/N/PE
Nominal Frequency	50/60Hz
Rated Power	100kW
Rated Apparent Power to Grid	100kVA
Max. Apparent Power to Grid	110kVA
Rated Current to Grid	152.0A@380Va.c. 144.4A@400Va.c. 139.2A@415Va.c.
Max. Current to Grid	167.2A@380Va.c. 158.8A@400Va.c. 153.1A@415Va.c.
Rated Apparent Power from Grid	100kVA
Max. Apparent Power from Grid	110kVA
Rated Current from Grid	152.0A
Max. Current from Grid	167.2A
Power Factor	-1(0.8lagging to 0.8leading)
Back-up(with STS)	
Nominal Output Voltage	220/380, 230/400, 240/415Va.c.,3L/N/PE
Nominal Output Frequency	50/60Hz
Rated Output Apparent Power	100kVA
Max. Output Apparent Power	110kVA
Rated Output Current	152.0A@380Va.c. 144.4A@400Va.c. 139.2A@415Va.c.
Max. Output Current	167.2A@380Va.c. 158.8A@400Va.c. 153.1A@415Va.c.
Operating Temperature Range	-35~+60°C
Non-isolated, IP66, Protective Class: I, OVC: DC II/AC III	
XXXXXXXXXX	
	
Check Code:	
FENECON GmbH Gewerbepark 6 94547 Iggenbach Deutschland www.fenecon.de service@fenecon.de	
	

Prüfbericht-Nr.: CN25J408 002
Test Report No.:

Seite 4 von 10
 Page 4 of 10

Produktbeschreibung
Product description

Possible test case verdicts:

- test case does not apply to the test object.....: N/A
- test object was not evaluated for the requirement.....: N/E
- test object does meet the requirement.....: Pass (P)
- test object does not meet the requirement: Fail (F)

Testing:

Date of receipt of test items: See cover page
 Date(s) of performance of tests: See cover page

General remarks:

"(see Attachment #)" refers to additional information appended to the report.
 "(see appended table)" refers to a table appended to the report.
 The tests results presented in this report relate only to the object tested.
 This report shall not be reproduced except in full without the written approval of the testing laboratory.
 List of test equipment must be kept on file and available for review.
 Additional test data and/or information provided in the attachments to this report.
 Throughout this report a comma / point is used as the decimal separator.
 Generator reference system:

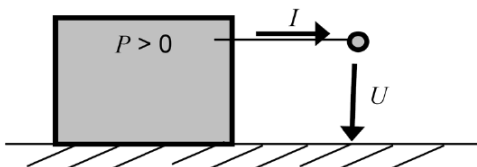

Produktbeschreibung
Product description

General product information:

Product Description:

The equipment FINV-100-1-DAH is three-phase hybrid inverter (bi-directional converter) designed to work with PV panels up to 1000Vd.c and batteries up to 800Vd.c. It is responsible for converting the direct current generated by photovoltaic panels and batteries into Three-phase 380/400/415V, 50/60 Hz alternative current for feeding into the electrical power distribution grid.

The PCEs don't provide galvanic separation between the PV/Battery input and AC output circuit (Non-isolation or transformer-less type).

The default mode is grid-connected, for off-grid mode, it must be realized through an external STS device. As part of the certification process, the product was considered without the STS module.

The phase conductor and neutral conductor of AC output circuit are equipped with two relays in series respectively, which can be switched off when the inverter shut down for the redundant protection.

External overcurrent device for Battery ports and AC ports shall be provided in field installation and specified in the installation manual.

Functional safety assessment is conducted for the output relay topology solution and AC type battery retarder relay according to IEC 60730-1 Annex H, see test report CN25NMW4 001 for details.

Block Diagram:

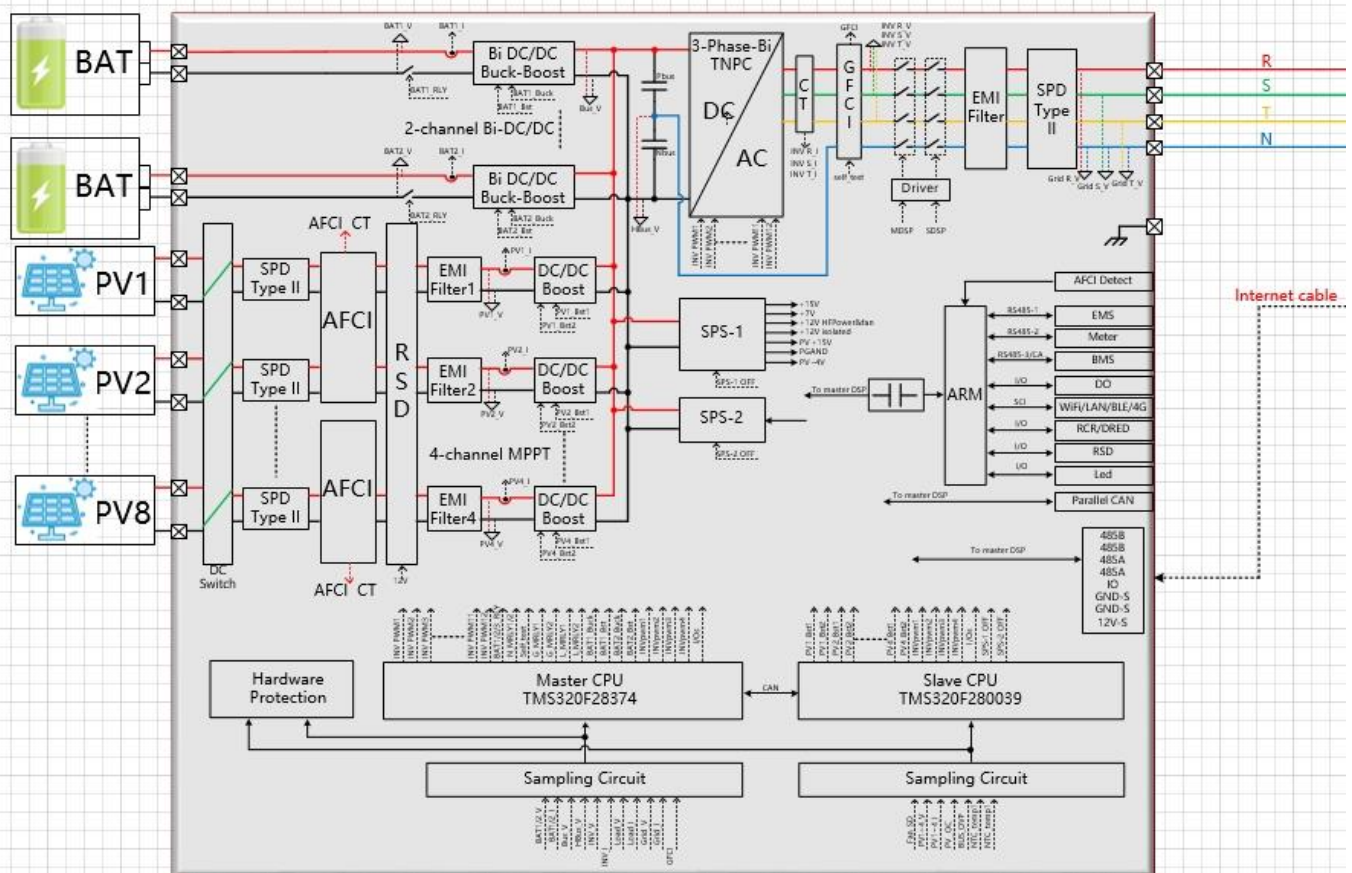

Block Diagram

Prüfbericht-Nr.: CN25J408 002
Test Report No.:

Seite 6 von 10
Page 6 of 10

Produktbeschreibung
Product description

Firmware version: 010101

Serial Number: 9075KNBC257L8001(for model FINV-100-1-DAH)

Temperature: 25°C

Relative humidity: 65%

Throughout the test report following abbreviations may be used:

cl	clearance	s-c	short-circuit
dcr	creepage distance	o-c	open-circuit
dti	distance through insulation	o-l	overload
BI	basic insulation	SI	supplementary insulation
DI	double insulation	RI	reinforced insulation

Model Name	Original Model Name
FINV-100-1-DAH	GW100K-ET-G10

History of amendments and modifications:

Test Report No.	Date (yyyy-mm-dd)	Remark(s)
CN25J408 001	2025-09-08	Original report
CN25J408 002	2026-02-06	FENECON GmbH Co-license

The test data is originally from test report CN2J408 001. No extra testing is required. The FINV-100-1-DAH is identical to GW100K-ET-G10 of GoodWe Technologies Co., Ltd, except for model name, trademark and license holder. See following pages for details.

Prüfbericht-Nr.: CN25J408 002
Test Report No.:

Seite 7 von 10
Page 7 of 10

Produktbeschreibung
Product description

Model list:

MODELS LIST		FINV-100-1-DAH
PV Side	V _{MAX} PV [Vdc]	1000
	I _{sc} PV [A]	55*8
	MPP Voltage Range [Vdc]	160~950
	Max. Input Current [A]	42*8
	MPP Full Power Voltage Range [Vdc]	500~850
	Start-up Voltage [Vdc]	200
	MPPT strings	2
	MPPT tracking	8
	Backfeed Current [A]	0
	Overvoltage Category (OVC)	II
AC Side	Rated Output Voltage [Vac]	220/380, 230/400, 240/415, 3L/N/PE
	Rated Output Frequency [Hz]	50/60
	Rated Output Power [kW]	100
	Max. Apparent Power [kVA]	110
	Rated Output Current [A]	152.0@380Vac 144.4@400Vac 139.2@415Vac
	Max. Output Current [A]	167.2 @380Vac 158.8 @400Vac 153.1 @415Vac
	Power Factor	~1 [0.8lagging-0.8leading]
Overvoltage Category (OVC)	III	
Back up	Max. Apparent power [kVA]	110
	Rated Output Voltage [Vac]	220/380, 230/400, 240/415, 3L/N/PE
	Max. Output Current [A]	167.2 @380Vac 158.8 @400Vac 153.1 @415Vac
	Rated Output Frequency [Hz]	50/60
	Overvoltage Category (OVC)	III
Battery Side	Battery Type	Li-ion battery
	V _{MAX} BAT [Vdc]	800
	Voltage Range [Vdc]	300~800
	Start Voltage [Vdc]	300
	Max. Charge/Discharge Current [A]	110*2/110*2

Prüfbericht-Nr.: CN25J408 002
Test Report No.:

Seite 8 von 10
Page 8 of 10

Produktbeschreibung
Product description

	Max. Charge/Discharge Power (kW)	110/110
	Overvoltage Category (OVC)	II
System	Type of inverter	Transformerless
	Protective Class	I
	Enclosure Protection (IP)	IP66
	Operating Temperature Range [°C]	-35 to +60 (>45 derating)
	Pollution degree (PD)	PD2(inside), PD3(outside)
	Altitude [m]	Up to 4000
	Size [mm]	995×758×358 (W*H*D)
	Weight [kg]	97

Prüfbericht-Nr.: CN25J408 002
Test Report No.:

Seite 9 von 10
Page 9 of 10

Produktbeschreibung
Product description

2	Maße / Gewicht <i>Dimensions / Weight</i>	Please refer to the user manual.
3	Bedienelemente <i>Operating elements</i>	N/A
4	Ausstattung / Zubehör <i>Equipment / Accessories</i>	N/A
5	Verwendete Materialien <i>Used materials</i>	N/A
6	Sonstiges <i>Other</i>	N/A

1	Anwendungsbereich Scope Details zur Ausgestaltung der messtechnischen Nachweise und zur Dokumentation der Messergebnisse sind in DIN VDE-V 0124-100 (VDE V 0124-100):2020-06 beschrieben. <i>Details on the design of the measuring certificates and the documentation of the measurement results are described in DIN VDE-V 0124-100 (VDE V 0124-100):2020-06.</i>
---	--

Prüfbericht-Nr.: CN25J408 001
Test Report No.:

Seite 10 von 10
Page 10 of 10

ZUSATZ-DOKUMENTATION
ADDITIONAL DOCUMENTATION

See CN25J408 002 Attachment 1 for test report of VDE V 0124-100: 2020-181 pages.
See CN25J408 002 Attachment 2 for Photo documentation-5 pages.

Prüfbericht-Nr.: CN25J408 002 Attachment 1
Test Report No.:

Seite 1 von 181
Page 1 of 181

Produktbeschreibung
Product description

See test report CN25J408 002 for details.

Prüfbericht-Nr.: CN25J408 002 Attachment 1
Test Report No.:

Seite 2 von 181
Page 2 of 181

Absatz	Anforderungen-Prüfungen	Messergebnisse-Bemerkungen	Bewertung
Clause	Requirements-Tests	Measuring results-Remarks	Evaluation

1	Anwendungsbereich Scope		
	Diese DIN-VDE-Vornorm dient dem Nachweis der elektrischen Eigenschaften von Erzeugungseinheiten (EZE) nach der VDE-AR N 4105:2018-11 und gegebenenfalls anderen Netzanschlussbedingungen. <i>This DIN VDE preliminary standard serves to verify the electrical properties of power generation units (PGU) in accordance with VDE-AR N 4105:2018-11 and, if applicable, other grid connection conditions.</i>		
5	Prüfungen Tests		
5.1	Allgemeines General information		P
5.2	Nachweis zulässiger Netzurückwirkungen Verification of permitted network reaction		P
5.3	Nachweis des Symmetrieverhaltens von Umrichtern Verification of symmetry behaviour of inverter		P
5.4	Nachweis des Verhaltens der Erzeugungseinheit am Netz Verification of behaviours of PGU on grid		P
5.5	Nachweis des NA-Schutzes Verification of NS-protections		N/A
5.6	Zuschaltbedingungen und Synchronisierung Connection conditions and synchronuzation		P
5.7	Nachweis der PAV,E-überwachung Verification of PAV,E-monitoring		P
5.8	Nachweis der dynamischen Netzstützung Verifiatiion of dynamic network supporting		P

Prüfbericht-Nr.: CN25J408 002 Attachment 1
Test Report No.:

Seite 3 von 181
Page 3 of 181

ZUSATZ-DOKUMENTATION
ADDITIONAL DOCUMENTATION

See following data for details.

Prüfbericht-Nr.: CN25J408 002 Attachment 1
Test report no.:

Seite 4 von 181
 Page 4 of 181

Test items	Remark
5.2 Verification of permitted network reaction	Pass
5.2.2 Rapid voltage change (Kimax)	Pass
5.2.3 Flicker	Pass
5.2.4 Harmonics and Inter-harmonics (I inter, I higher)	Pass
5.2.5 Commutation notches	Pass
5.2.6 DC current feeding to network (Idc)	Pass
5.3 Verification of symmetry behaviours of inverter	Pass
5.3.2 Tests of three-phase inverter (Imbalance)	Pass
5.3.3 Symmetry operation with a symmetry device	N/A
5.4 Verification of behaviours of PGU on network	Pass
5.4.2 Measurement of active- and reactive power ranges (P&Q range)	Pass
5.4.3 Active power reduction through setting provision (P control)	Pass
5.4.4 Active power output of PGU by over-frequency (LFSM-O)	Pass
5.4.5 Active power output of ESS by over-frequency (LFSM-O)	N/A
5.4.6 Active power output of PGU by under-frequency (LFSM-U)	Pass
5.4.7 Active power output of ESS by under-frequency (LFSM-U)	N/A
5.4.8.2 Tests of reactive power / displacement factor setting accuracy (Fixed $\cos\phi$)	Pass
5.4.8.3 Tests of displacement factor- / active power character curve ($\cos\phi(P)$)	Pass
5.4.8.4 Tests of reactive power-voltage character curve (Q(U))	Pass
5.5 Verification of NS-protection*	N/A
5.5.2 NS-protection	N/A
5.5.3 Central NS-protecton	N/A
5.5.4 Integrated NS-protection	N/A
5.5.6 Interface switch (Functional safety)	N/A
5.5.7 Protection devices and protection settings (OV/UV, OF/UF)	N/A
5.5.9 Constructional features of NS protection	N/A
5.5.10 Islanding detection	N/A
5.6 Connection conditions and synchronization (Reconnection)	Pass
5.7 Verification of $P_{AV,E}$ monitoring	Pass
5.8 Verification of dynamic network supporting (FVRT)	Pass
Note(s): *The verification on integrated interface switch is only implemented on unit less than 30kVA. For unit over 30kVA, the integrated switch shall be functioned together with central NS protection and verified additionally.	

Prüfbericht-Nr.: CN25J408 002 Attachment 1	Seite 5 von 181
<i>Test report no.:</i>	<i>Page 5 of 181</i>

5.2.2	TABLE: Rapid voltage change (Kimax)			P
Test Conditions	Measurements			Limit
	U/Un	I/In	Ki	Ki
Starting to 50%Pn	1.00	0.48	0.48	≤ 1.2
Starting to 100% Pn	1.00	0.97	0.97	≤ 1.2
Stopping at 100% Pn	1.00	1.00	1.00	≤ 1.2
Note(s):				

5.2.3	TABLE: Flicker							P	
L1									
Test Condition	Measurement								
	30°		50°		70°		85°		
P/Pn [%]	Pst	C _{ψk}	Pst	C _{ψk}	Pst	C _{ψk}	Pst	C _{ψk}	
10	0.0004	0.0064	0.0004	0.0063	0.0004	0.0063	0.0004	0.0065	
20	0.0004	0.0059	0.0004	0.0059	0.0004	0.0059	0.0004	0.0059	
30	0.0005	0.0074	0.0005	0.0074	0.0005	0.0074	0.0005	0.0074	
40	0.0005	0.0068	0.0005	0.0068	0.0005	0.0069	0.0005	0.0069	
50	0.0089	0.1334	0.0089	0.1337	0.0089	0.1337	0.0089	0.1336	
60	0.0008	0.0119	0.0009	0.0129	0.0009	0.0128	0.0009	0.0133	
70	0.0095	0.1422	0.0095	0.1423	0.0095	0.1422	0.0095	0.1421	
80	0.0004	0.0064	0.0004	0.0065	0.0004	0.0066	0.0004	0.0066	
90	0.0004	0.0060	0.0004	0.0061	0.0004	0.0062	0.0004	0.0063	
100	0.0092	0.1382	0.0093	0.1394	0.0091	0.1366	0.0091	0.1358	
100	0.0095	0.1425	0.0095	0.1425	0.0095	0.1427	0.0095	0.1427	
100	0.0093	0.1391	0.0093	0.1391	0.0093	0.1395	0.0093	0.1396	
L2									
Test Condition	Measurement								
	30°		50°		70°		85°		
P/Pn [%]	Pst	C _{ψk}	Pst	C _{ψk}	Pst	C _{ψk}	Pst	C _{ψk}	
10	0.0004	0.0064	0.0004	0.0062	0.0004	0.0062	0.0004	0.0063	
20	0.0004	0.0059	0.0004	0.0059	0.0004	0.0060	0.0004	0.0060	
30	0.0005	0.0070	0.0005	0.0071	0.0005	0.0071	0.0005	0.0071	
40	0.0005	0.0068	0.0005	0.0068	0.0005	0.0068	0.0005	0.0068	
50	0.0091	0.1365	0.0091	0.1366	0.0091	0.1365	0.0091	0.1366	
60	0.0009	0.0130	0.0008	0.0127	0.0009	0.0141	0.0010	0.0145	
70	0.0093	0.1395	0.0093	0.1398	0.0093	0.1397	0.0093	0.1397	
80	0.0004	0.0054	0.0004	0.0055	0.0004	0.0056	0.0004	0.0056	
90	0.0092	0.1387	0.0092	0.1385	0.0092	0.1385	0.0092	0.1385	
100	0.0095	0.1431	0.0096	0.1433	0.0096	0.1435	0.0096	0.1434	
100	0.0093	0.1402	0.0093	0.1399	0.0093	0.1395	0.0093	0.1394	
100	0.0094	0.1411	0.0094	0.1406	0.0093	0.1402	0.0093	0.1401	

Prüfbericht-Nr.: CN25J408 002 Attachment 1
 Test report no.:

Seite 6 von 181
 Page 6 of 181

L3								
Test Condition	Measurement							
	30°		50°		70°		85°	
P/Pn [%]	Pst	C _{ψk}	Pst	C _{ψk}	Pst	C _{ψk}	Pst	C _{ψk}
10	0.0006	0.0093	0.0006	0.0093	0.0006	0.0093	0.0006	0.0093
20	0.0006	0.0093	0.0006	0.0093	0.0006	0.0093	0.0006	0.0093
30	0.0007	0.0098	0.0007	0.0098	0.0007	0.0098	0.0007	0.0098
40	0.0006	0.0092	0.0006	0.0093	0.0006	0.0093	0.0006	0.0093
50	0.0089	0.1341	0.0090	0.1345	0.0090	0.1344	0.0089	0.1339
60	0.0010	0.0157	0.0011	0.0161	0.0010	0.0157	0.0010	0.0151
70	0.0094	0.1414	0.0094	0.1416	0.0095	0.1418	0.0095	0.1418
80	0.0008	0.0116	0.0008	0.0117	0.0008	0.0118	0.0008	0.0118
90	0.0093	0.1392	0.0093	0.1388	0.0093	0.1389	0.0093	0.1390
100	0.0092	0.1383	0.0092	0.1381	0.0092	0.1387	0.0092	0.1387
100	0.0094	0.1414	0.0094	0.1414	0.0094	0.1414	0.0094	0.1414
100	0.0093	0.1389	0.0092	0.1387	0.0092	0.1387	0.0092	0.1387

Note(s): PGU and ESS with nominal current > 75A (Per FGW TR3 Ver25)

5.2.4	TABLE: linter & lhigher											P
Harmonics												
P/P _n [%]	0	10	20	30	40	50	60	70	80	90	100	Limit
Order No.	I/In [%]											
2	0.001	0.050	0.040	0.052	0.076	0.092	0.096	0.110	0.128	0.151	0.224	--
3	0.003	0.046	0.061	0.060	0.079	0.093	0.089	0.094	0.095	0.093	0.101	--
4	0.000	0.035	0.038	0.049	0.037	0.045	0.043	0.045	0.049	0.055	0.063	--
5	0.009	0.569	0.801	0.713	0.795	0.770	0.738	0.752	0.787	0.825	0.869	--
6	0.000	0.032	0.035	0.038	0.042	0.053	0.057	0.061	0.061	0.057	0.066	--
7	0.012	0.322	0.381	0.445	0.546	0.532	0.499	0.468	0.436	0.423	0.414	--
8	0.001	0.064	0.102	0.115	0.118	0.130	0.140	0.152	0.156	0.136	0.144	--
9	0.004	0.160	0.206	0.199	0.113	0.111	0.160	0.186	0.211	0.222	0.230	--
10	0.000	0.067	0.108	0.123	0.128	0.130	0.112	0.104	0.102	0.094	0.092	--
11	0.011	0.832	0.985	0.649	0.248	0.207	0.338	0.430	0.511	0.543	0.552	--
12	0.000	0.046	0.051	0.060	0.072	0.090	0.092	0.098	0.105	0.098	0.110	--
13	0.020	0.614	0.715	0.948	0.452	0.132	0.340	0.480	0.546	0.548	0.555	--
14	0.000	0.057	0.072	0.076	0.087	0.101	0.129	0.148	0.156	0.139	0.160	--
15	0.003	0.056	0.065	0.136	0.185	0.155	0.171	0.155	0.126	0.099	0.110	--
16	0.001	0.053	0.081	0.080	0.104	0.128	0.112	0.109	0.103	0.092	0.102	--
17	0.029	0.411	0.624	0.756	0.591	0.382	0.199	0.241	0.355	0.387	0.418	--
18	0.001	0.050	0.059	0.066	0.078	0.096	0.099	0.105	0.108	0.103	0.116	--
19	0.012	0.528	0.587	0.479	0.558	0.465	0.351	0.366	0.427	0.461	0.496	--
20	0.001	0.052	0.072	0.076	0.087	0.093	0.109	0.123	0.135	0.130	0.148	--
21	0.007	0.052	0.056	0.121	0.119	0.136	0.135	0.147	0.144	0.127	0.128	--
22	0.001	0.050	0.069	0.068	0.075	0.095	0.096	0.098	0.100	0.092	0.104	--
23	0.028	0.314	0.272	0.368	0.351	0.322	0.336	0.294	0.274	0.321	0.368	--
24	0.001	0.046	0.052	0.058	0.067	0.081	0.088	0.094	0.101	0.101	0.116	--
25	0.037	0.265	0.291	0.435	0.325	0.273	0.326	0.291	0.281	0.292	0.317	--
26	0.001	0.045	0.052	0.055	0.066	0.079	0.086	0.095	0.106	0.107	0.125	--
27	0.019	0.041	0.059	0.052	0.062	0.106	0.095	0.095	0.096	0.093	0.111	--
28	0.001	0.043	0.049	0.049	0.055	0.070	0.079	0.085	0.094	0.093	0.112	--
29	0.037	0.121	0.340	0.235	0.197	0.199	0.240	0.208	0.194	0.183	0.199	--
30	0.002	0.038	0.041	0.044	0.050	0.065	0.073	0.080	0.088	0.091	0.111	--
31	0.043	0.136	0.186	0.116	0.161	0.218	0.209	0.225	0.244	0.233	0.253	--
32	0.002	0.034	0.039	0.040	0.046	0.061	0.066	0.074	0.082	0.086	0.104	--
33	0.014	0.034	0.037	0.044	0.076	0.058	0.079	0.071	0.077	0.083	0.098	--
34	0.001	0.033	0.034	0.037	0.042	0.054	0.061	0.067	0.074	0.075	0.092	--
35	0.021	0.120	0.093	0.152	0.132	0.165	0.156	0.176	0.201	0.203	0.210	--
36	0.001	0.045	0.047	0.050	0.056	0.063	0.066	0.070	0.075	0.078	0.090	--
37	0.012	0.084	0.073	0.102	0.108	0.090	0.085	0.110	0.131	0.118	0.111	--
38	0.001	0.028	0.028	0.031	0.035	0.045	0.050	0.056	0.060	0.061	0.071	--
39	0.014	0.047	0.043	0.050	0.043	0.053	0.059	0.061	0.064	0.061	0.068	--
40	0.001	0.025	0.025	0.029	0.013	0.042	0.044	0.049	0.041	0.043	0.042	--

Prüfbericht-Nr.: CN25J408 002 Attachment 1	Seite 8 von 181
<i>Test report no.:</i>	Page 8 of 181

Inter-harmonics												
P/Pn [%]	0	10	20	30	40	50	60	70	80	90	100	Limit
f [Hz]	I/In [%]											
75	0.001	0.031	0.033	0.036	0.041	0.050	0.055	0.058	0.060	0.056	0.065	--
125	0.002	0.029	0.032	0.036	0.041	0.050	0.055	0.057	0.060	0.059	0.066	--
175	0.000	0.035	0.038	0.041	0.049	0.059	0.064	0.066	0.068	0.064	0.072	--
225	0.005	0.039	0.042	0.047	0.053	0.065	0.070	0.071	0.074	0.070	0.078	--
275	0.000	0.044	0.048	0.053	0.061	0.074	0.079	0.081	0.083	0.076	0.085	--
325	0.002	0.044	0.048	0.054	0.062	0.076	0.082	0.085	0.086	0.080	0.089	--
375	0.001	0.055	0.060	0.068	0.080	0.097	0.103	0.105	0.106	0.097	0.107	--
425	0.004	0.060	0.067	0.076	0.090	0.109	0.115	0.118	0.120	0.108	0.121	--
475	0.001	0.064	0.072	0.082	0.097	0.119	0.124	0.127	0.130	0.116	0.130	--
525	0.011	0.067	0.075	0.087	0.104	0.126	0.133	0.136	0.138	0.123	0.137	--
575	0.001	0.070	0.079	0.091	0.109	0.132	0.139	0.142	0.145	0.130	0.144	--
625	0.021	0.072	0.082	0.094	0.113	0.136	0.145	0.147	0.150	0.134	0.150	--
675	0.000	0.075	0.084	0.097	0.116	0.139	0.147	0.150	0.153	0.138	0.154	--
725	0.003	0.076	0.086	0.099	0.118	0.142	0.151	0.155	0.157	0.140	0.157	--
775	0.001	0.077	0.088	0.101	0.119	0.143	0.152	0.156	0.158	0.142	0.159	--
825	0.009	0.078	0.089	0.102	0.119	0.141	0.151	0.155	0.158	0.143	0.161	--
875	0.001	0.078	0.089	0.101	0.117	0.141	0.151	0.156	0.157	0.143	0.161	--
925	0.012	0.077	0.089	0.100	0.114	0.139	0.149	0.155	0.157	0.144	0.161	--
975	0.001	0.076	0.087	0.098	0.111	0.136	0.147	0.152	0.155	0.143	0.159	--
1025	0.007	0.075	0.086	0.097	0.109	0.133	0.145	0.149	0.155	0.143	0.159	--
1075	0.001	0.072	0.084	0.094	0.106	0.131	0.142	0.147	0.154	0.142	0.161	--
1125	0.008	0.071	0.081	0.092	0.103	0.127	0.139	0.145	0.153	0.145	0.162	--
1175	0.001	0.069	0.079	0.087	0.099	0.124	0.136	0.144	0.152	0.145	0.166	--
1225	0.007	0.067	0.076	0.085	0.095	0.120	0.131	0.140	0.150	0.146	0.167	--
1275	0.001	0.065	0.073	0.081	0.091	0.116	0.128	0.137	0.149	0.146	0.170	--
1325	0.019	0.063	0.070	0.077	0.087	0.111	0.124	0.133	0.146	0.144	0.171	--
1375	0.001	0.061	0.067	0.073	0.083	0.107	0.120	0.129	0.141	0.142	0.171	--
1425	0.037	0.059	0.064	0.070	0.079	0.102	0.115	0.125	0.137	0.140	0.170	--
1475	0.002	0.057	0.061	0.066	0.076	0.097	0.110	0.120	0.133	0.135	0.165	--
1525	0.003	0.055	0.058	0.064	0.073	0.093	0.106	0.116	0.127	0.130	0.160	--
1575	0.002	0.052	0.056	0.060	0.069	0.089	0.102	0.111	0.121	0.125	0.153	--
1625	0.004	0.051	0.054	0.058	0.067	0.085	0.096	0.106	0.117	0.118	0.145	--
1675	0.001	0.049	0.051	0.055	0.064	0.081	0.092	0.101	0.110	0.112	0.136	--
1725	0.001	0.047	0.049	0.053	0.061	0.077	0.088	0.095	0.104	0.106	0.126	--
1775	0.001	0.045	0.046	0.050	0.058	0.073	0.083	0.091	0.099	0.099	0.119	--
1825	0.012	0.044	0.045	0.048	0.056	0.070	0.079	0.086	0.094	0.093	0.111	--
1875	0.001	0.042	0.043	0.047	0.054	0.066	0.076	0.082	0.089	0.088	0.104	--
1925	0.004	0.041	0.041	0.045	0.052	0.064	0.071	0.078	0.084	0.083	0.097	--
1975	0.001	0.040	0.039	0.043	0.050	0.061	0.068	0.074	0.080	0.079	0.091	--

Higher frequency Harmonics												
P/P _n [%]	0	10	20	30	40	50	60	70	80	90	100	Limit
f [kHz]	I/In [%]											
2.1	0.001	0.025	0.024	0.026	0.030	0.038	0.040	0.044	0.049	0.048	0.055	--
2.3	0.001	0.021	0.020	0.021	0.025	0.031	0.034	0.037	0.040	0.039	0.045	--
2.5	0.001	0.018	0.019	0.020	0.022	0.026	0.027	0.029	0.032	0.032	0.037	--
2.7	0.001	0.016	0.018	0.020	0.020	0.026	0.023	0.024	0.025	0.025	0.029	--
2.9	0.001	0.015	0.018	0.020	0.022	0.026	0.027	0.028	0.028	0.027	0.029	--
3.1	0.001	0.014	0.018	0.021	0.024	0.027	0.029	0.031	0.031	0.031	0.032	--
3.3	0.001	0.013	0.015	0.016	0.017	0.020	0.021	0.021	0.020	0.021	0.021	--
3.5	0.001	0.012	0.014	0.015	0.017	0.018	0.020	0.020	0.020	0.020	0.020	--
3.7	0.001	0.011	0.013	0.012	0.016	0.017	0.018	0.019	0.017	0.019	0.019	--
3.9	0.001	0.012	0.013	0.014	0.015	0.019	0.018	0.019	0.019	0.018	0.019	--
4.1	0.000	0.011	0.012	0.014	0.017	0.015	0.017	0.017	0.012	0.017	0.018	--
4.3	0.000	0.010	0.012	0.013	0.016	0.015	0.015	0.016	0.017	0.017	0.017	--
4.5	0.000	0.010	0.014	0.013	0.014	0.015	0.015	0.017	0.019	0.017	0.017	--
4.7	0.001	0.009	0.010	0.012	0.013	0.015	0.015	0.017	0.017	0.015	0.017	--
4.9	0.001	0.009	0.010	0.011	0.013	0.014	0.015	0.015	0.015	0.015	0.017	--
5.1	0.000	0.008	0.009	0.011	0.010	0.013	0.014	0.015	0.017	0.015	0.017	--
5.3	0.001	0.007	0.008	0.009	0.010	0.014	0.016	0.014	0.012	0.015	0.017	--
5.5	0.001	0.007	0.008	0.009	0.009	0.010	0.011	0.012	0.013	0.015	0.015	--
5.7	0.001	0.007	0.007	0.008	0.008	0.008	0.009	0.015	0.011	0.013	0.015	--
5.9	0.001	0.005	0.007	0.005	0.008	0.008	0.011	0.010	0.013	0.015	0.019	--
6.1	0.001	0.005	0.007	0.007	0.007	0.007	0.008	0.009	0.010	0.013	0.015	--
6.3	0.001	0.005	0.005	0.005	0.005	0.005	0.005	0.007	0.007	0.008	0.009	--
6.5	0.001	0.004	0.004	0.005	0.005	0.005	0.005	0.005	0.005	0.007	0.007	--
6.7	0.001	0.004	0.004	0.004	0.004	0.004	0.005	0.005	0.005	0.005	0.005	--
6.9	0.001	0.003	0.004	0.004	0.004	0.004	0.004	0.004	0.005	0.005	0.005	--
7.1	0.001	0.003	0.003	0.002	0.003	0.003	0.004	0.004	0.004	0.004	0.005	--
7.3	0.001	0.003	0.003	0.003	0.003	0.003	0.003	0.004	0.004	0.004	0.005	--
7.5	0.001	0.003	0.003	0.003	0.003	0.003	0.003	0.003	0.004	0.004	0.004	--
7.7	0.001	0.003	0.001	0.003	0.003	0.003	0.003	0.003	0.003	0.003	0.004	--
7.9	0.001	0.002	0.002	0.002	0.002	0.003	0.003	0.003	0.003	0.003	0.004	--
8.1	0.001	0.002	0.002	0.002	0.002	0.002	0.003	0.003	0.003	0.003	0.003	--
8.3	0.001	0.002	0.002	0.002	0.002	0.002	0.002	0.002	0.003	0.003	0.003	--
8.5	0.001	0.002	0.002	0.002	0.002	0.002	0.002	0.002	0.002	0.003	0.003	--
8.7	0.001	0.002	0.002	0.002	0.002	0.002	0.002	0.002	0.002	0.002	0.002	--
8.9	0.001	0.002	0.002	0.002	0.002	0.002	0.002	0.002	0.002	0.002	0.003	--

Note(s): The max. value of three phases were chosen.

5.2.5	TABLE: Commutation notches			P
Test Conditions P/ P _{E_{max}}	Measurements			
	I _{com} [A]			
	L1	L2	L3	
25% - 35%	0.0	0.0	0.0	
65% - 75%	0.0	0.0	0.0	
> 90%	0.0	0.0	0.0	
Note(s):				

5.2.6	TABLE: DC current feeding to network (I _{dc})			P
Test Conditions P/ P _{E_{max}}	Measurements			Limit
	I _{dc} / I _n [%]			I _{dc} /I _n
	L1	L2	L3	
30% - 40%	0.07	0.16	0.09	0.5%
60% - 70%	0.10	0.23	0.12	0.5%
> 95%	0.16	0.34	0.14	0.5%
Note(s):				

5.3.2	TABLE: Tests of three-phase inverter (Imbalance)					P	
Test Conditions		Measurements					Limit
cosφ	S/S _{E_{max}} [%]	S _{asy} /S _{E_{max}} [%]					S _{asy} /S _{E_{max}} [%]
1.0	100	0.279	0.276	0.275	0.273	0.272	≤ ±5
1.0	50	0.323	0.325	0.325	0.323	0.325	
0.80un	100	0.028	0.031	0.031	0.032	0.033	
0.80un	50	0.081	0.080	0.082	0.083	0.082	
0.80ov	100	0.297	0.270	0.250	0.260	0.301	
0.80ov	50	0.465	0.460	0.440	0.452	0.443	
Note(s):							
S _{asy} : Max. Asymmetry power among three phases.							

5.4.2		TABLE: Measurement of active- and reactive power ranges (P&Q range)				P		
Test Conditions		Measurements				Δ Limit		
U/Un	cosφ	U [V]	P _{max} [kW]	cosφ	S _{max} [kVA]	cosφ	P _{max} / P _{Emax}	S _{max} / S _{Emax}
0.9	1.0	207.23	99.86	0.99	99.890	--	≤102%	≤102%
1.0		230.22	100.0	0.99	100.11			
1.09		250.90	100.11	0.99	100.13			
0.95	Max.un	218.67	99.02	-0.90	109.71	≤0.9(5)		
1.0		230.18	99.25	-0.90	110.10			
1.09		250.86	99.30	-0.90	110.16			
0.9	Max.ov	207.29	94.34	0.90	104.43			
1.0		230.29	98.90	0.90	109.52			
1.05		241.77	98.93	0.90	109.57			

Note(s):

5.4.3(a)		TABLE: Active power reduction through setting provision (P control)		P
Test Conditions		Measurements		Limit
P/Pn [%]		P/Pn [%]	ΔP/Pn [%]	Δ P/Pn [%]
100		100.00	0.00	≤ 5%
90		89.95	-0.05	
80		79.97	-0.03	
70		69.98	-0.02	
60		60.00	-0.00	
50		50.02	0.02	
40		40.03	0.03	
30		30.05	0.05	
20		20.04	0.04	
10		10.04	0.04	
No disconnection occurs				Y

5.4.3(b)		TABLE: Active power reduction through setting provision (P control)		P
Test Conditions		Measurements		Limit
P/Pn [%]		ΔP/Δt [%Pn/s]		ΔP/Δt [%Pn/s]
100->5		0.39		0.33-0.66
5->100		0.39		

5.4.3(c)	TABLE: Active power reduction through setting provision (P control)			P
Test Conditions			Measurements	Limit
P/Pn [%]			P/Pn [%]	P/Pn [%]
Interface port 1	Interface port 2	Interface port 3		
70	90	50	50.0	≤ 50
Com	Local	WiFi		
P/Pn [%]			P/Pn [%]	P/Pn [%]
Interface port 1	Interface port 2	Interface port 3		
60	100	80	59.9	≤ 60
Com	Local	WiFi		
P/Pn [%]			P/Pn [%]	P/Pn [%]
Interface port 1	Interface port 2	Interface port 3		
90	50	70	50.0	≤ 50
Com	Local	WiFi		

5.4.3(d)	TABLE: Active power reduction through setting provision (P control)		P
Test Conditions		Measurements	Limit
P/Pn [%]		T _{response} [s]	T _{response} [s]
100->0		0.244	≤ 5
Note(s):			

5.4.4(a)		TABLE: Active power output of PGU by over-frequency (LFSM-O)							P					
LFSM-O settings		f_{active}		f_{stop}			$f_{deactive}$		Droop					
		50.2		N/A			50.2		5%(40%P _M /Hz)					
Test Conditions		Measurements					Target	Tolerance	Limit					
f [Hz]	P _{rim} [%]	P/P _{Emax} [%]	f [Hz]	T _{rise} [s]	T _{set} [s]	T _v [s]	P/P _{Emax} [%]	ΔP/P _{Emax} [%]	ΔP [%]	T _{rise} [s]	T _{set} [s]			
50.00	100	99.36	49.99	--	--	--	100	0.64	≤±10	≤2	≤20			
50.25	100	97.40	50.25	0.4	0.8	0.1	98	0.60						
50.70	100	79.53	50.69	0.2	0.8	0.1	80	0.47						
51.40	100	51.90	51.39	0.4	0.5	0.1	52	0.10						
50.70	100	79.58	50.70	0.5	0.5	0.2	80	0.42						
50.25	100	97.31	50.25	0.4	0.6	0.1	98	0.69						
50.00	100	99.41	50.00	0.3	0.4	0.1	100	0.59						
51.65	100	Disconnection												
50.15	100	No reconnection												
Test Conditions		Measurements					Target	Tolerance				Limit		
f [Hz]	P _{rim} [%]	P/P _{Emax} [%]	f [Hz]	ΔP/Δt [%/min]		P/P _{Emax} [%]	ΔP/P _{Emax} [%]	ΔP [%]	ΔP/Δt [%/min]					
50.00	100	100.08	50.00	8.1		100	0.08	≤±10	≤10					

Note(s):

Plotting diagram:

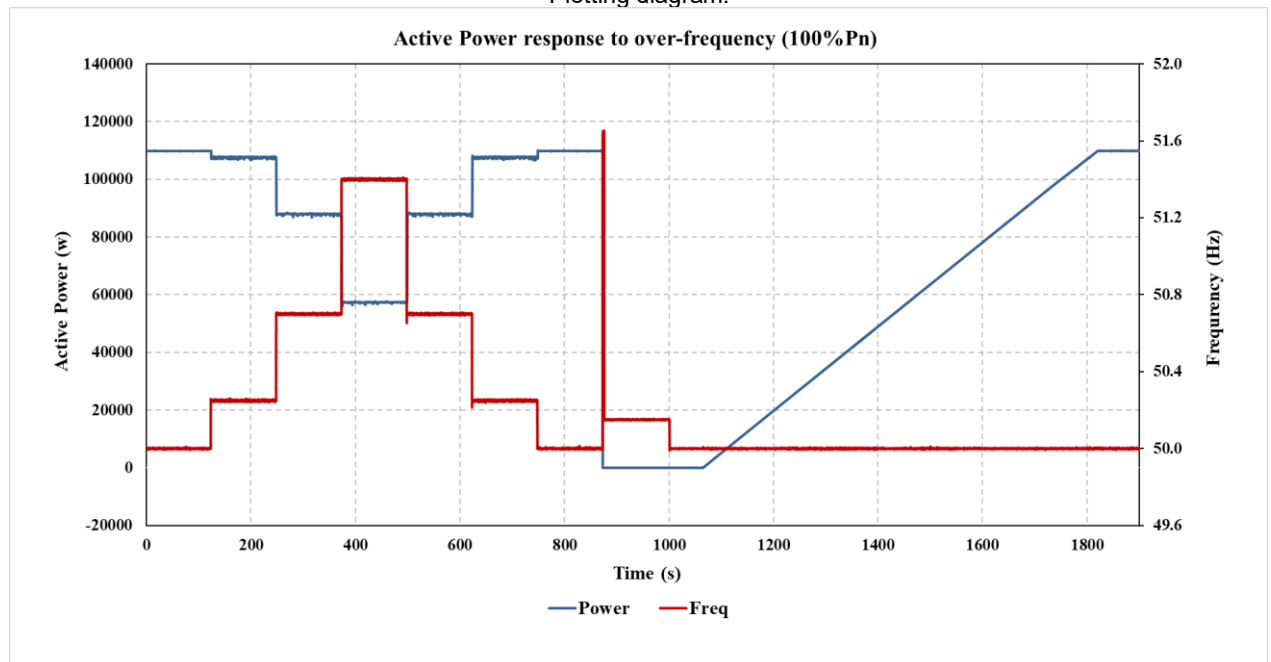

5.4.4(b)		TABLE: Active power output of PGU by over-frequency (LFSM-O)							P		
LFSM-O settings		f_{active}		f_{stop}			$f_{deactive}$		Droop		
		50.5		N/A			50.2		12%(16.67%P _M /Hz)		
Test Conditions		Measurements					Target	Tolerance	Limit		
f [Hz]	P _{rim} [%]	P/P _E max [%]	f [Hz]	T _{rise} [s]	T _{set} [s]	T _v [s]	P/P _E max [%]	ΔP/P _E max [%]	ΔP [%]	T _{rise} [s]	T _{set} [s]
50.00	60	60.04	50.00	--	--	--	60	0.04	≤±10	≤2	≤20
50.40	60	60.45	50.40	--	--	--	60	0.45			
50.70	60->100	57.91	50.70	0.6	0.8	0.1	58	0.09			
51.40	100	51.01	51.40	0.6	0.8	0.1	51	0.01			
50.70	100	57.88	50.70	0.5	0.8	0.1	58	0.12			
Test Conditions		Measurements					Target	Tolerance	Limit		
f [Hz]	P _{rim} [%]	P/P _E max [%]	f [Hz]	ΔP/Δt [%/min]			P/P _E max [%]	ΔP/P _E max [%]	ΔP [%]	ΔP/Δt [%/min]	
50.40	100	59.81	50.40	8.8			60	0.19	≤±10	≤10	
50.00	100	99.44	50.00	--			100	0.56	≤±10	--	

Note(s):

Plotting diagram:

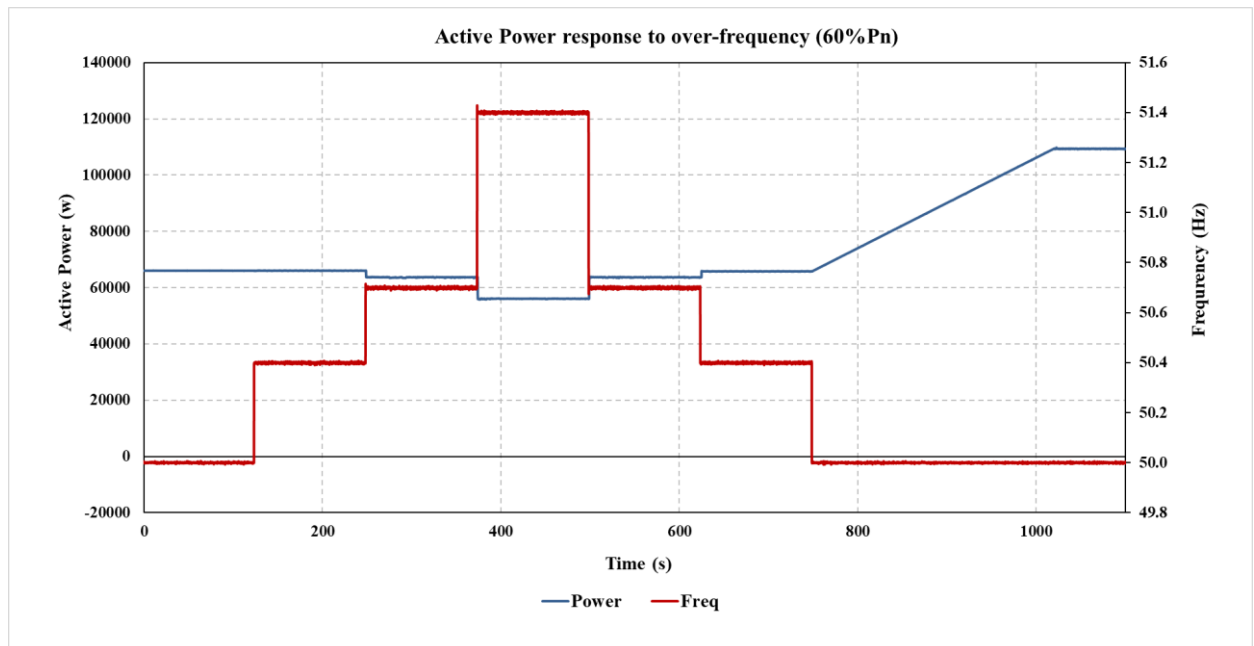

5.4.6(a)		TABLE: Active power output of PGU by under-frequency (LFSM-U)							P					
LFSM-U settings		f_{active}		f_{stop}			$f_{deactive}$		Droop					
		49.8		N/A			49.8		5%(40%P _{E_{max}} /Hz)					
Test Conditions		Measurements					Target	Tolerance	Limit					
f [Hz]	P _{rim} [%]	P/P _{E_{max}} [%]	f [Hz]	T _{rise} [s]	T _{set} [s]	T _v [s]	P/P _{E_{max}} [%]	$\Delta P/P_{E_{max}}$ [%]	ΔP [%]	T _{rise} [s]	T _{set} [s]			
50.00	100	10.04	50.00	--	--	--	10	0.04	$\leq \pm 10$	≤ 2	≤ 20			
49.75	100	12.13	49.75	1.20	1.20	0.40	12	0.13						
48.80	100	49.91	48.80	1.10	1.10	0.40	50	0.09						
47.60	100	97.84	47.60	0.90	0.90	0.10	98	0.16						
48.80	100	50.42	48.80	0.70	0.70	0.00	50	0.42						
49.75	100	12.32	49.75	1.50	1.60	0.30	12	0.32						
50.00	100	10.04	50.00	1.00	1.00	0.30	10	0.04						
47.35	100	Disconnection												
47.40	100	No Reconnection												
Test Conditions		Measurements				Target	Tolerance	Limit						
f [Hz]	P _{rim} [%]	P/P _{E_{max}} [%]	f [Hz]	$\Delta P/\Delta t$ [%/min]	P/P _{E_{max}} [%]	$\Delta P/P_{E_{max}}$ [%]	ΔP [%]	$\Delta P/\Delta t$ [%/min]						
50.00	100	9.91	50.00	7.8	10	-0.09	$\leq \pm 10$	≤ 10						

Note(s):

Product power was limited to 10% at the beginning of test by a lower priority command from user.

Plotting diagram:

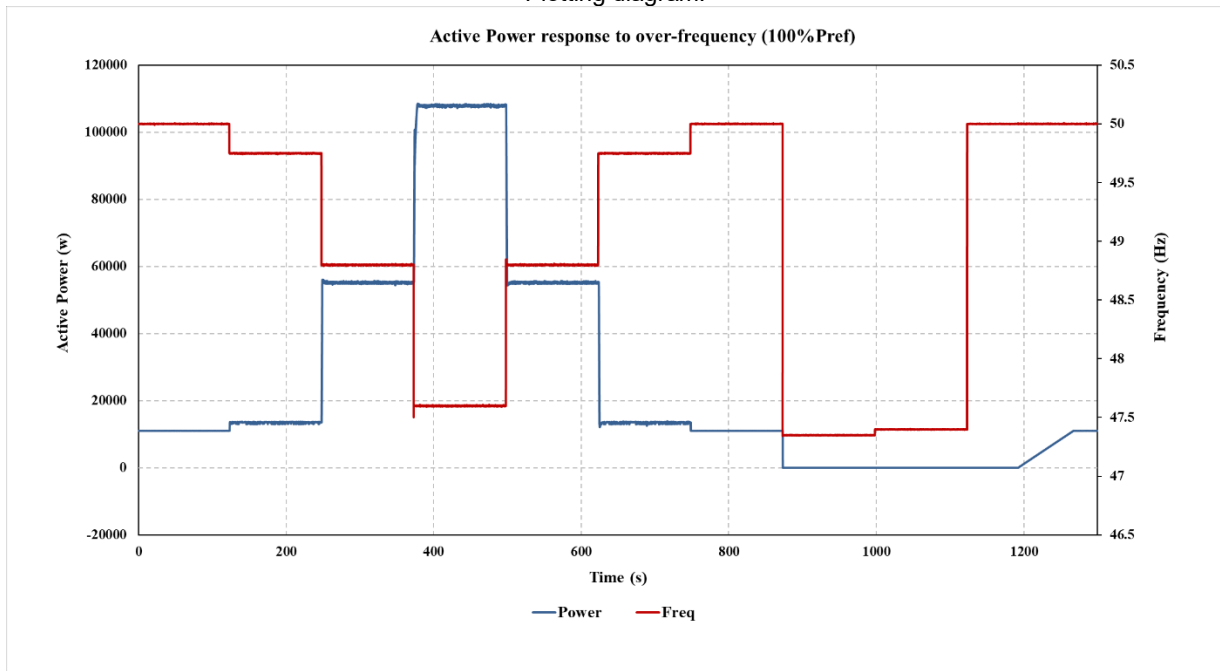

5.4.6(b)		TABLE: Active power output of PGU by under-frequency (LFSM-U)							P		
LFSM-U settings		f _{active}		f _{stop}			f _{deactive}		Droop		
		49.8		N/A			49.8		5%(40%P _{E_{max}} /Hz)		
Test Conditions		Measurements					Target	Tolerance	Limit		
f [Hz]	P _{rim} [%]	P/P _{E_{max}} [%]	f [Hz]	T _{rise} [s]	T _{set} [s]	T _v [s]	P/P _{E_{max}} [%]	ΔP/P _{E_{max}} [%]	ΔP [%]	T _{rise} [s]	T _{set} [s]
50.00	100	59.96	50.00	--	--	--	60	-0.04	≤±10	≤2	≤20
49.75	100	61.92	49.75	1.00	1.00	0.30	62	-0.08			
49.20	100	84.06	49.20	1.20	1.20	0.40	84	0.06			
48.80	100	100.02	48.80	1.00	1.00	0.30	100	0.02			
49.20	100	84.04	49.20	1.20	1.20	0.40	84	0.04			
49.85	100	59.97	49.85	1.30	1.30	0.30	60	-0.03			
50.00	100	59.97	50.00	--	--	--	60	-0.03			

Note(s):

Product power was limited to 60% at the beginning of test by a lower priority command from user.

Plotting diagram:

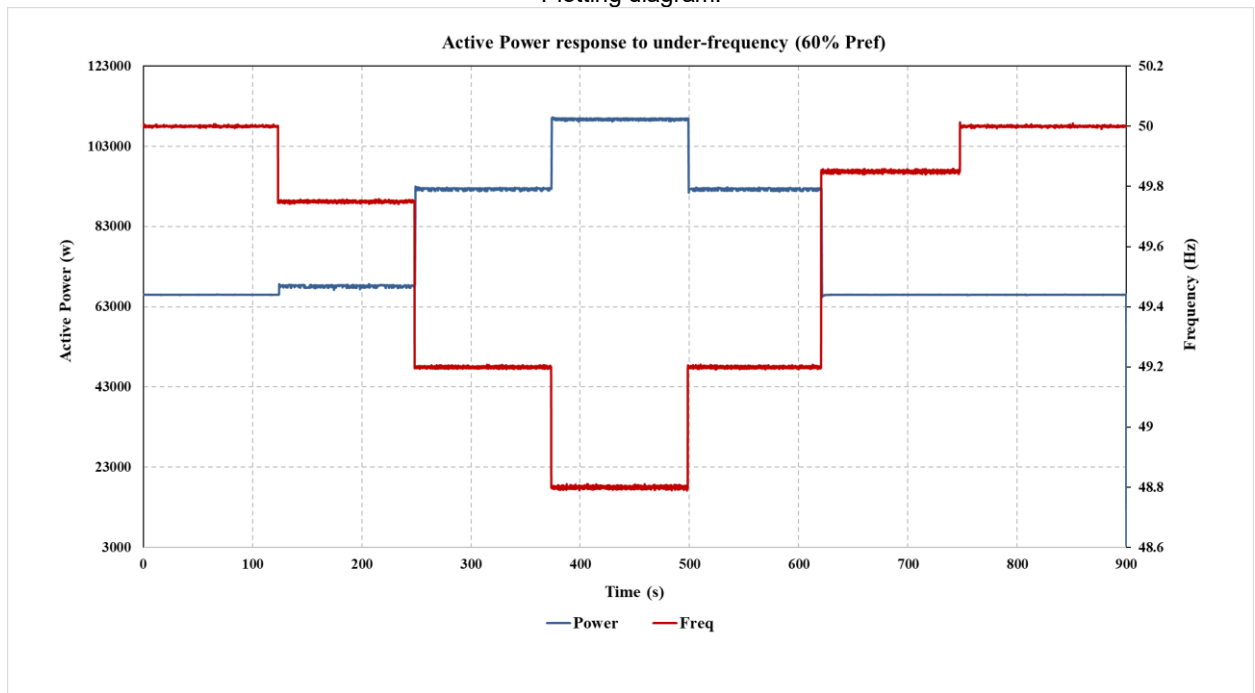

5.4.8.2			TABLE: Tests of reactive power / displacement factor setting accuracy (Fixed cosφ)						P	
Test Conditions			Measurements					Target	Tolerance	Limit
U/Un [%]	P/PEmax [%]	cosφ	P [kW]	Q [kVar]	S [kVA]	U [V]	cosφ	Q [kVar]	ΔQ/PEmax [%]	ΔQ/PEmax [%]
90	50	0.90 under-excited	55.445	-26.707	61.542	207.12	-0.901	-26.60	0.190%	≤± 4
90	SEmax		94.60	-45.5	104.99	207.16	-0.901	-45.70	0.180%	≤± 4
100	50		55.45	-26.542	61.475	230.12	-0.902	-26.60	0.010%	≤± 4
100	SEmax		99.277	-47.805	110.187	230.17	-0.901	-47.90	0.095%	≤± 4
110	50		55.474	-26.682	61.558	253.11	-0.901	-26.60	0.082%	≤± 4
110	SEmax		99.372	-47.738	110.244	253.15	-0.901	-47.90	0.162%	≤± 4
90	50	0.95 under-excited	55.299	-18.09	58.183	207.11	-0.950	-18.10	0.01%	≤± 4
90	SEmax		99.476	-31.439	104.326	207.17	-0.954	-31.80	0.361%	≤± 4
100	50		55.329	-18.12	58.221	230.12	-0.950	-18.10	0.000%	≤± 4
100	SEmax		104.641	-34.311	110.123	230.17	-0.950	-34.34	0.029%	≤± 4
110	50		55.366	-18.069	58.212	253.1	-0.951	-18.10	0.031%	≤± 4
110	SEmax		104.698	-34.239	110.154	253.15	-0.950	-34.34	0.101%	≤± 4
90	50	0.90 over-excited	55.495	26.479	61.489	207.19	0.903	26.60	0.121%	≤± 4
90	SEmax		94.353	44.782	104.443	207.27	0.903	45.70	0.918%	≤± 4
100	50		55.013	26.246	60.954	230.15	0.903	26.60	0.354%	≤± 4
100	SEmax		99.122	47.234	109.803	230.25	0.903	47.90	0.042%	≤± 4
110	50		55.09	26.201	61.004	253.13	0.903	26.60	0.399%	≤± 4
110	SEmax		99.099	47.186	109.761	253.22	0.903	47.90	0.714%	≤± 4
90	50	0.95 over-excited	55.076	17.778	57.875	207.15	0.952	18.10	0.313%	≤± 4
90	SEmax		99.002	31.739	103.966	207.24	0.952	31.80	0.061%	≤± 4
100	50		55.020	17.727	57.805	230.15	0.952	18.10	0.373%	≤± 4
100	SEmax		104.403	33.879	109.763	230.25	0.951	34.34	0.0465	≤± 4
110	50		55.016	17.790	57.821	253.13	0.951	18.10	0.310%	≤± 4
110	SEmax		104.444	33.733	109.757	253.22	0.952	34.34	0.001%	≤± 4

Note(s):

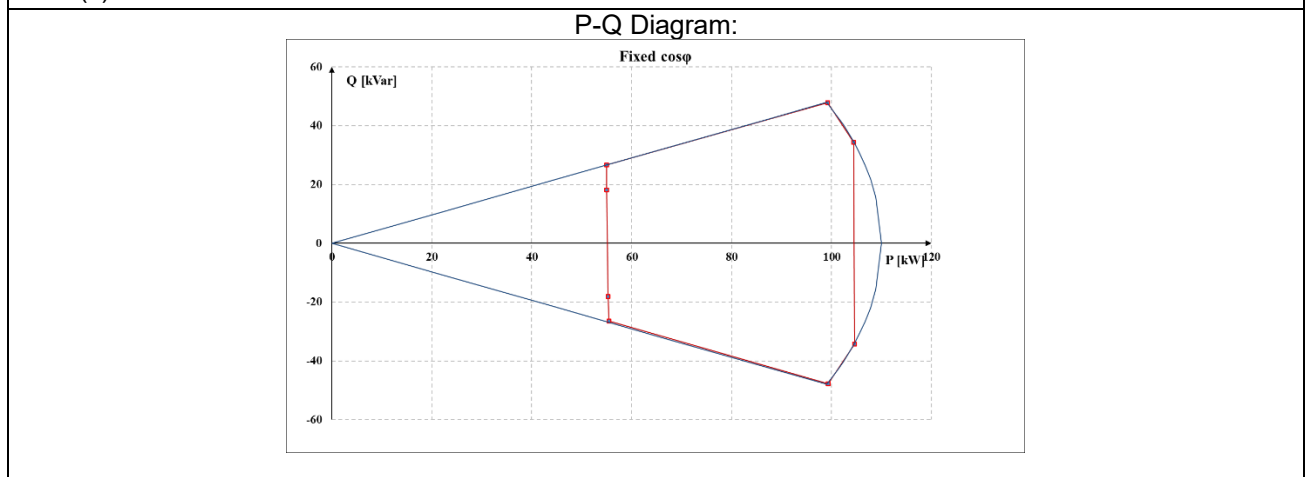

5.4.8.3(a)	TABLE: Tests of displacement factor- / active power character curve (cosφ(P))			P
cosφ (P) curve settings:	P/Pn [%]	10	50	100
	cosφ	1.0	1.0	0.9(5)
	3Tau [s]	10		
Test Conditions				Limit
$P_{dc}/P_{dc,r}$ [%]				$\Delta Q/P_{E_{max}}$ [%]
100->10->100 with ramp $\leq 30\%P_{dc,r}/\text{min}$				$\leq \pm 4.0$

Plotting diagram:

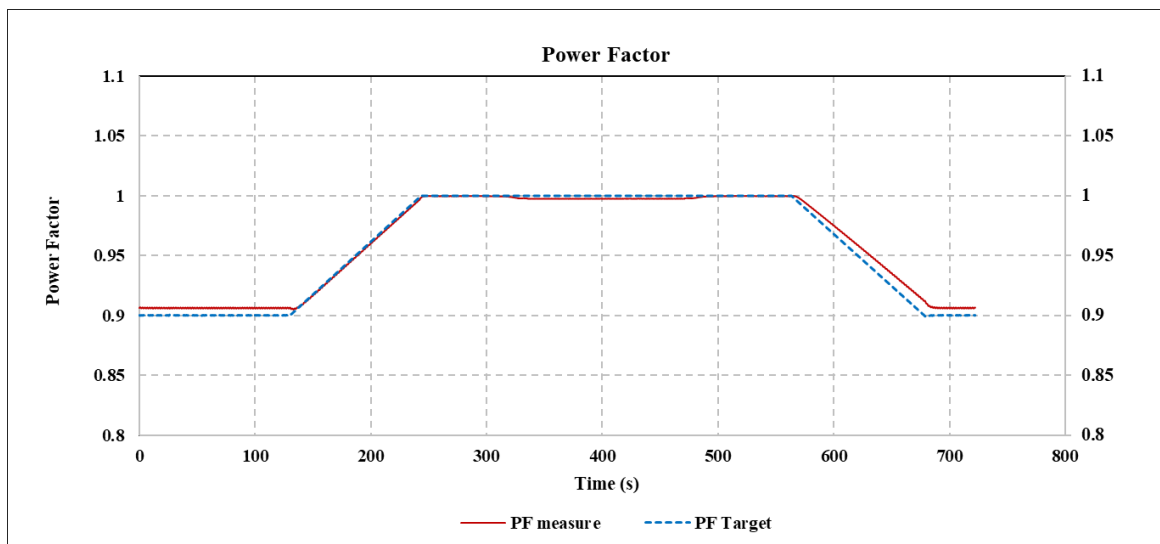
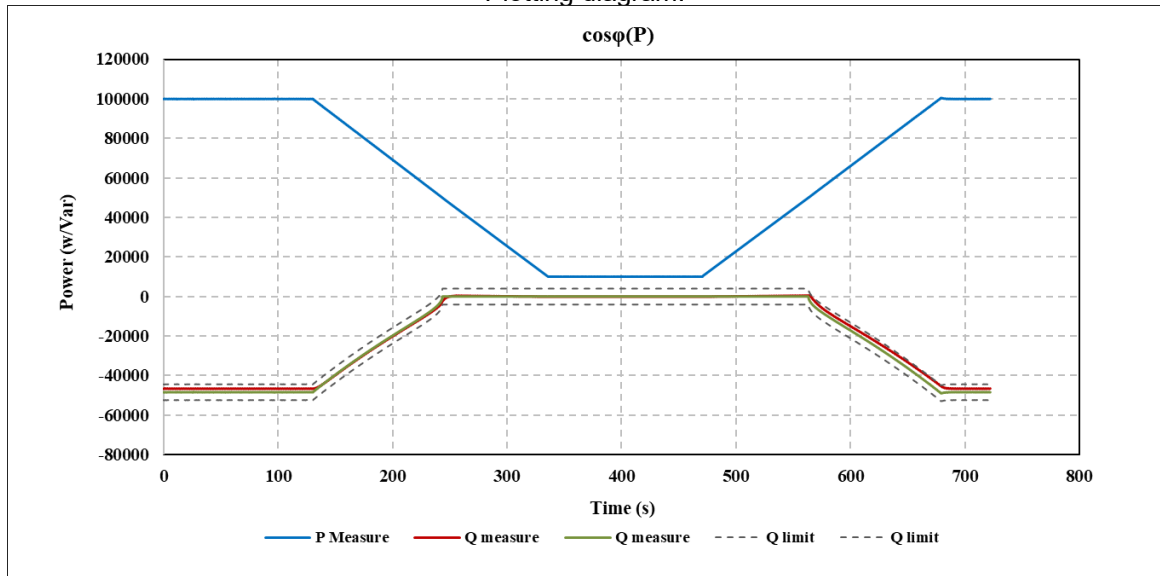

5.4.8.3(b)	TABLE: Tests of displacement factor- / active power character curve ($\cos\phi(P)$)	P
Test Conditions	Measurements	Limit
$P_{\text{rim}}/P_{\text{dc,r}}$ [%]	Response time T [s]	Response time T [s]
100->40	9.8	Complied with PT-1 curve
40->100	9.5	
100->75	8.4	

Plotting diagram:

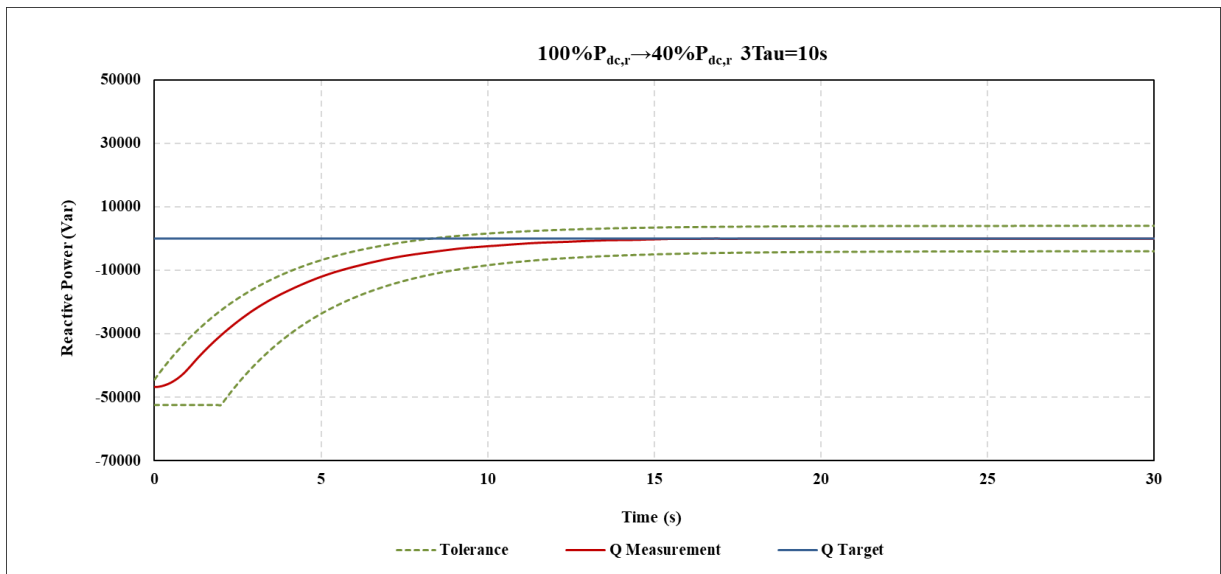
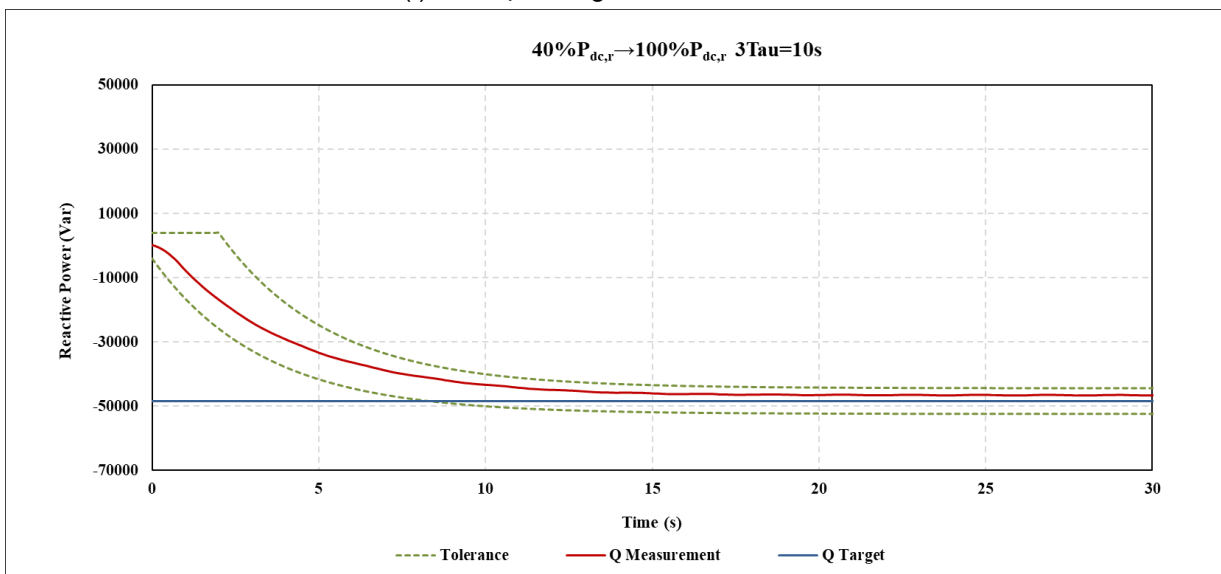
 $Q(t)$, P_{Primary} Setting: $100\%P_{\text{dc,r}} \rightarrow 40\%P_{\text{dc,r}}$

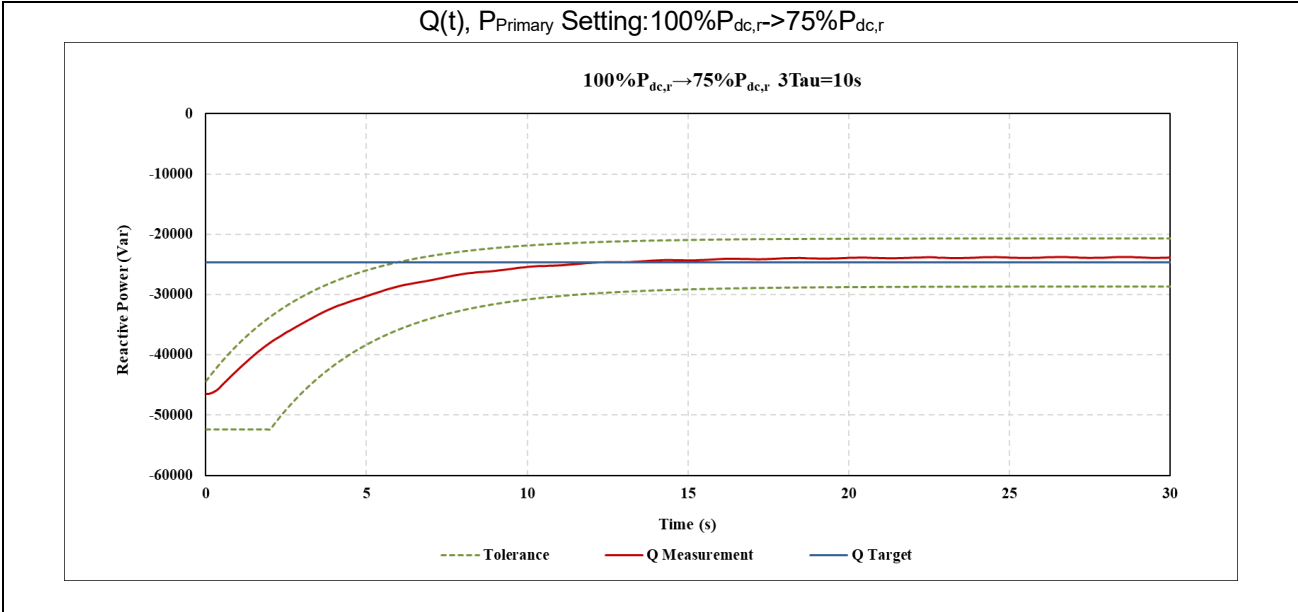
 $Q(t)$, P_{Primary} Setting: $40\%P_{\text{dc,r}} \rightarrow 100\%P_{\text{dc,r}}$

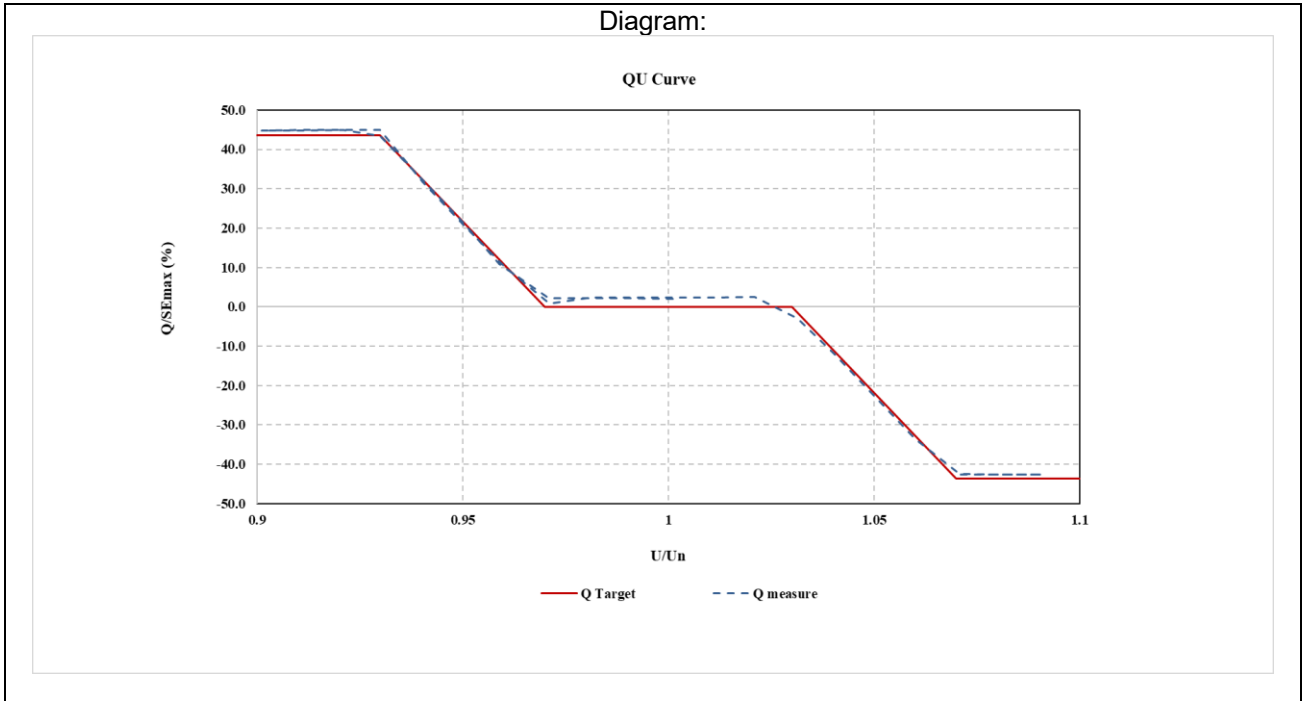

5.4.8.4(a)	TABLE: Tests of reactive power-voltage character curve (Q(U))					P
Q (U) curve settings:	U/Un	0.93	0.97	1.03	1.07	
	Q/SEmax	+0.436	0	0	-0.436	
	3Tau [s]	6				
Test Conditions		Measurements		Target	Tolerance	Limit
U/Un[%]		Q[kVar]	U [V]	Q[kVar]	$\Delta Q/P_{E_{max}}$ [%]	$\Delta Q/P_{E_{max}}$ [%]
100	2.15	230.24	0.0	1.95%	$\leq \pm 4$	
99	2.15	227.95	0.0	1.95%	$\leq \pm 4$	
98	2.15	225.64	0.0	1.95%	$\leq \pm 4$	
97	2.15	223.33	0.0	1.95%	$\leq \pm 4$	
96	10.84	220.56	12.0	-1.05%	$\leq \pm 4$	
95	21.45	218.54	24.0	-2.30%	$\leq \pm 4$	
94	32.15	216.26	36.0	-3.48%	$\leq \pm 4$	
93	44.38	213.87	47.9	-3.20%	$\leq \pm 4$	
92	44.91	211.84	47.9	-2.71%	$\leq \pm 4$	
91	44.83	209.26	47.9	-2.79%	$\leq \pm 4$	
90	44.84	207.26	47.9	-2.78%	$\leq \pm 4$	
91	44.96	209.57	47.9	-2.67%	$\leq \pm 4$	
92	44.98	211.84	47.9	-2.65%	$\leq \pm 4$	
93	44.93	213.87	47.9	-2.70%	$\leq \pm 4$	
94	31.63	216.28	36.0	-3.95%	$\leq \pm 4$	
95	20.87	218.54	24.0	-2.83%	$\leq \pm 4$	
96	10.20	220.85	12.0	-1.63%	$\leq \pm 4$	
97	0.84	223.34	0.0	0.77%	$\leq \pm 4$	
98	2.40	225.64	0.0	2.18%	$\leq \pm 4$	
99	2.41	227.94	0.0	2.19%	$\leq \pm 4$	
100	2.40	230.24	0.0	2.18%	$\leq \pm 4$	
101	2.39	232.56	0.0	2.17%	$\leq \pm 4$	
102	2.49	234.81	0.0	2.26%	$\leq \pm 4$	
103	-2.85	237.20	0.0	-2.59%	$\leq \pm 4$	
104	-11.97	239.26	-12.0	0.02%	$\leq \pm 4$	
105	-22.74	241.52	-24.0	1.13%	$\leq \pm 4$	
106	-33.51	243.80	-36.0	2.23%	$\leq \pm 4$	
107	-44.51	246.27	-47.9	3.09%	$\leq \pm 4$	
108	-44.56	248.58	-47.9	3.04%	$\leq \pm 4$	
109	-44.67	250.94	-47.9	2.94%	$\leq \pm 4$	
110	-44.66	248.58	-47.9	2.94%	$\leq \pm 4$	
109	-44.60	246.27	-47.9	3.00%	$\leq \pm 4$	
108	-44.58	243.77	-47.9	3.02%	$\leq \pm 4$	
107	-44.54	241.53	-47.9	3.06%	$\leq \pm 4$	
106	-33.60	243.80	-36.0	2.15%	$\leq \pm 4$	
105	-22.80	241.51	-24.0	1.07%	$\leq \pm 4$	
104	-12.18	239.23	-12.0	-0.17%	$\leq \pm 4$	
103	-2.13	237.13	0.0	-1.93%	$\leq \pm 4$	
102	2.32	234.81	0.0	2.11%	$\leq \pm 4$	
101	2.26	232.55	0.0	2.05%	$\leq \pm 4$	
100	2.22	230.21	0.0	2.02%	$\leq \pm 4$	

Diagram:



5.4.8.4(b)	TABLE: Tests of reactive power-voltage character curve (Q(U))					P
Test Conditions	Measurement			Target	Limit	
	Settling time T [s]	Q _{Start} [kVar]	Q _{end} [kVar]	Q _{end} /S _E max [%]	Settling time T [s]	$\Delta Q_{end}/P_{Emax}$ [%]
Un -> Un+ $\Delta U_{ind,Y}$	6.0	0.6	-37.9	-0.85Qmax	PT-1 complied, see attached curve for detail.	--
Un+ $\Delta U_{ind,Y}$ -> Un	6.0	-38.1	-2.41	0		$\leq \pm 4$
Un -> Un+ $\Delta U_{ind,Y}$	6.0	-2.1	-38.1	-0.85Qmax		--
Un+ $\Delta U_{ind,Y}$ -> Un	6.0	-38.1	-2.32	0		$\leq \pm 4$
Un -> Un+ $\Delta U_{ind,Y}$	6.0	-2.4	-38.1	-0.85Qmax		--
Un+ $\Delta U_{ind,Y}$ -> Un	6.0	-38.1	-2.3	0		$\leq \pm 4$
Un -> Un+ $\Delta U_{cap,Y}$	6.0	2.1	36.8	0.85Qmax		--
Un+ $\Delta U_{cap,Y}$ -> Un	6.0	36.9	2.2	0		$\leq \pm 4$
Un -> Un+ $\Delta U_{cap,Y}$	6.0	2.19	36.8	0.85Qmax		--
Un+ $\Delta U_{cap,Y}$ -> Un	6.0	36.8	2.1	0		$\leq \pm 4$
Un -> Un+ $\Delta U_{cap,Y}$	6.0	2.15	36.8	0.85Qmax		--
Un+ $\Delta U_{cap,Y}$ -> Un	6.0	36.8	2.23	0		$\leq \pm 4$

Plotting Diagram

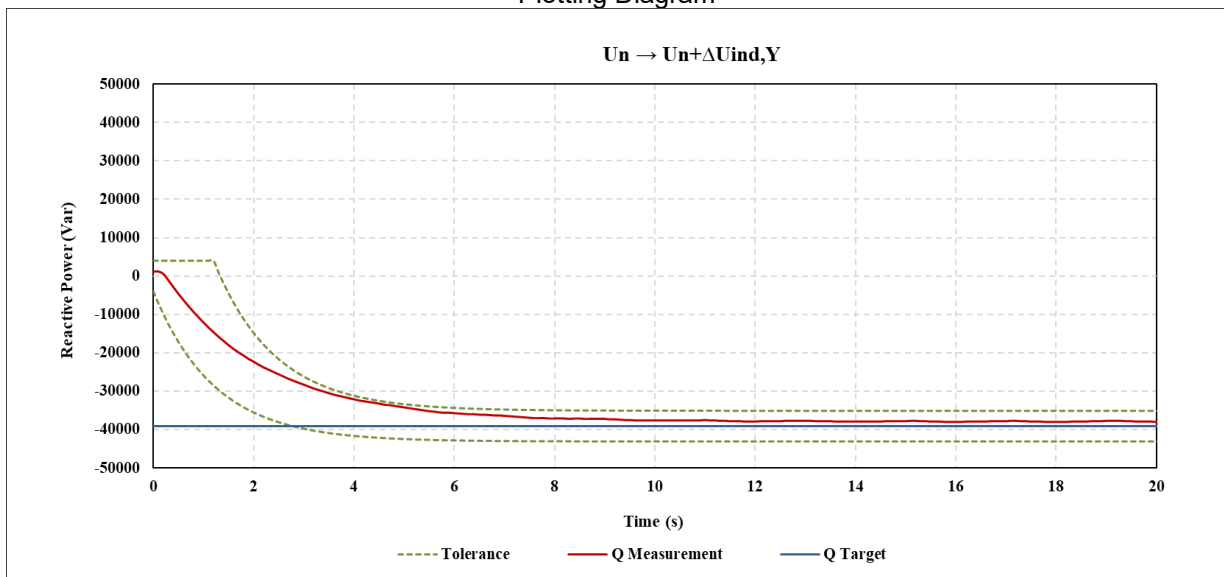

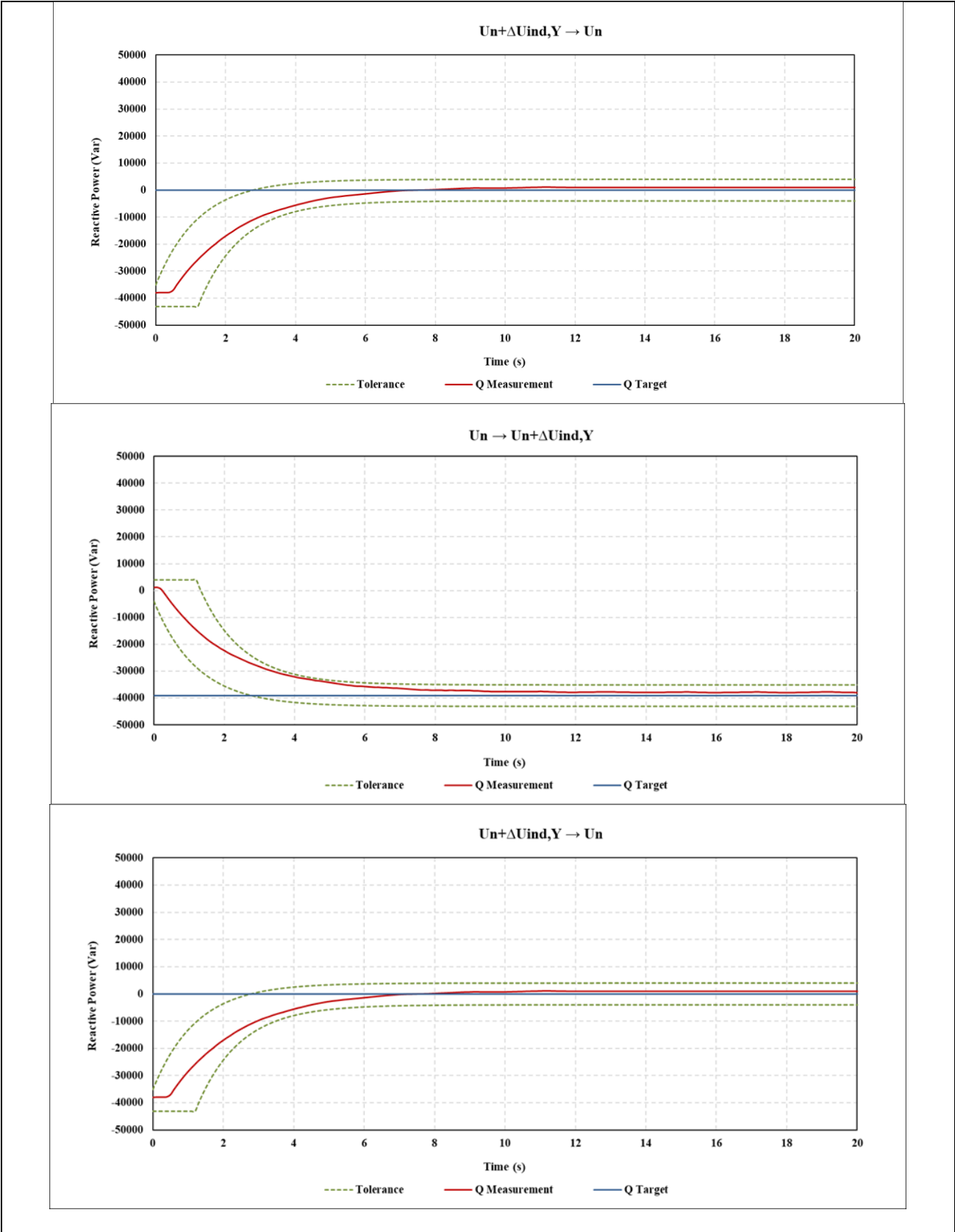

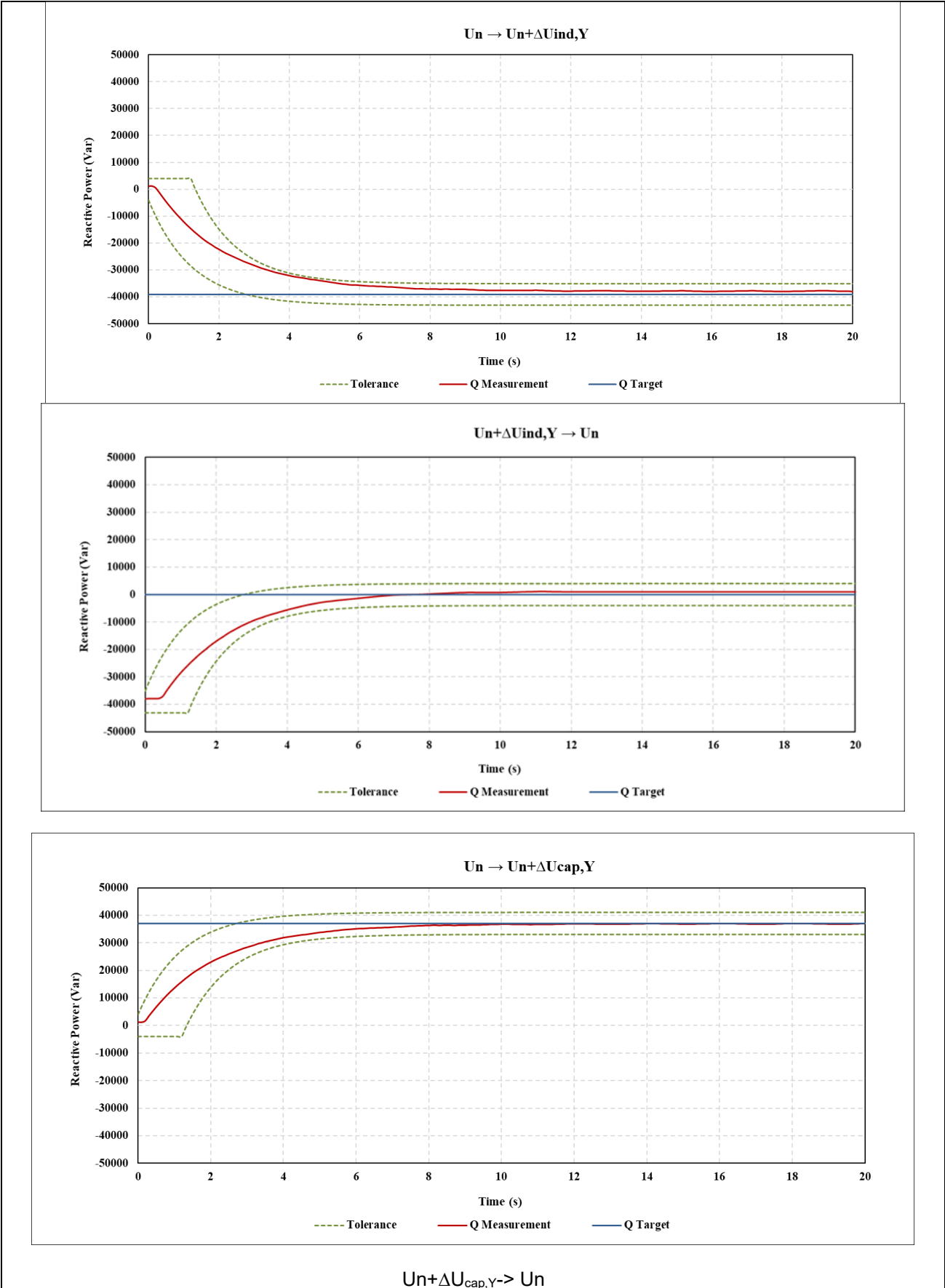

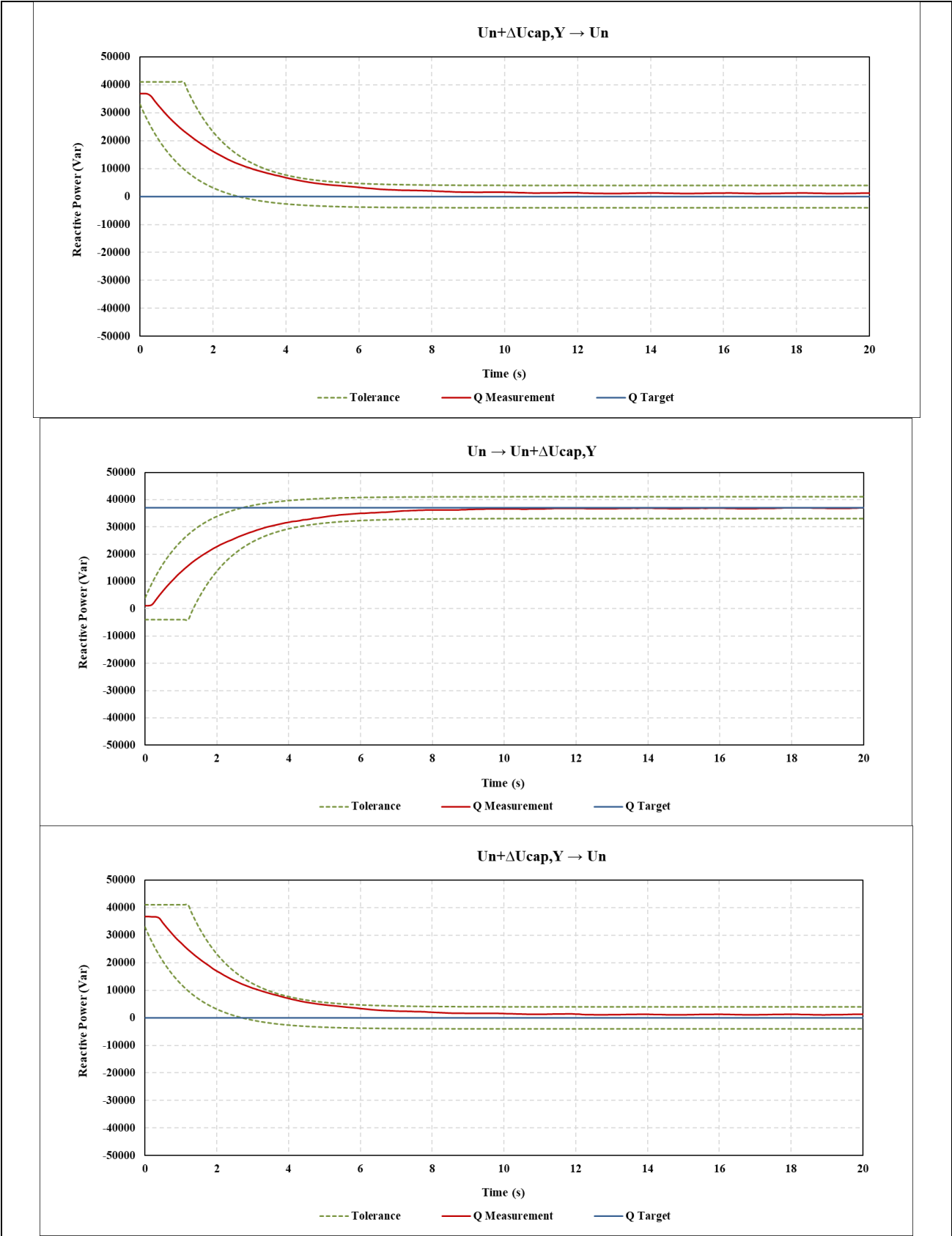

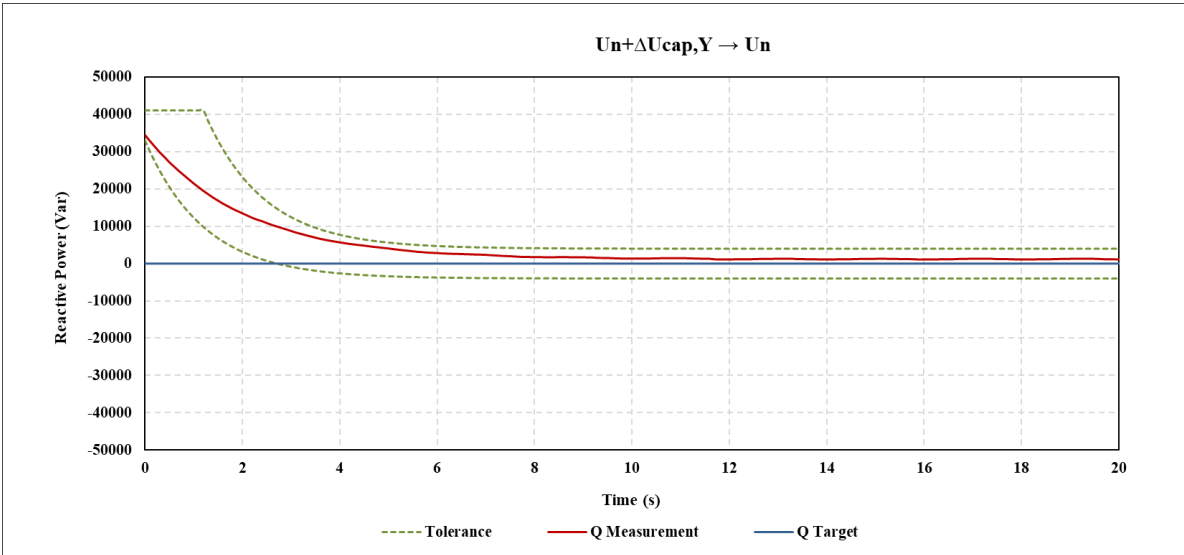
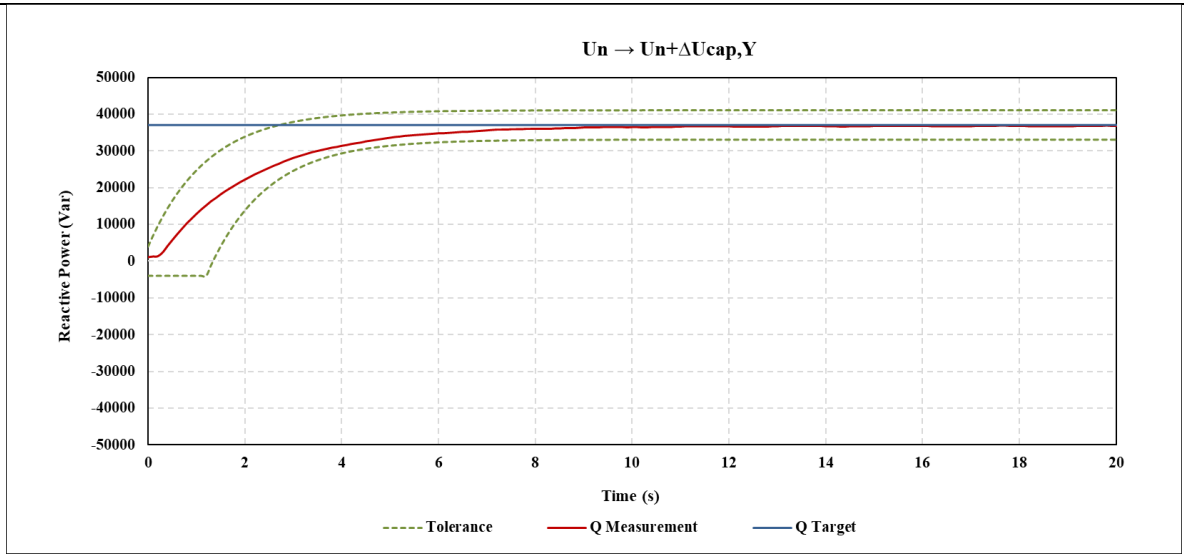

Note(s): Xnet=0.2829Ohm

Prüfbericht-Nr.: CN25J408 002 Attachment 1 <i>Test report no.:</i>	Seite 28 von 181 Page 28 of 181
--	------------------------------------

5.5.2, 5.5.4, 5.5.6	TABLE: NS-protection, Integrated interface switch (Functional safety)	P
The max. initial short-circuited current I_k'' [A]:	167.2	
Switch type:	HF172F-200/12	
Manufacturer:	Xiamen Hongfa Electroacoustic Co., Ltd.	
Switching capability [A]:	200	
DIN EN 62109-1 cert/report No.:	CN2500BC 001	
Ambient temperature (°C)	25	

5.6	TABLE: Connection conditions and synchronization (Reconnection)			P
Condition	Measurement		Limitation	
	Reconnection	Delay time [s]	Reconnection	Delay time [s]
$f < 47.45\text{Hz}$	No	--	No	≥ 60
$f \geq 47.55\text{Hz}$	Yes	78.3	Yes	≥ 60
$f > 50.15\text{Hz}$	No	--	No	≥ 60
$f \leq 50.05\text{Hz}$	Yes	73.2	Yes	≥ 60
$U < 0.84U_n$	No	--	No	≥ 60
$U \geq 0.86U_n$	Yes	73.4	Yes	≥ 60
$U > 1.11U_n$	No	--	No	≥ 60
$U \leq 1.09U_n$	Yes	73.2	Yes	≥ 60
Note(s):				

Prüfbericht-Nr.: CN25J408 002 Attachment 1 Test report no.:	Seite 29 von 181 Page 29 of 181
---	------------------------------------

5.7	TABLE: P _{AV,E} monitoring	P
P _{AV,E} value setting: 60% P _n		
Power limit method		
Test method	Condition	
Jump of primary energy	P _{rim} / P _{dc,r} : 60%->100%	
Cut of load	P _{load} /P _n : 40%->0%	

Power curve:

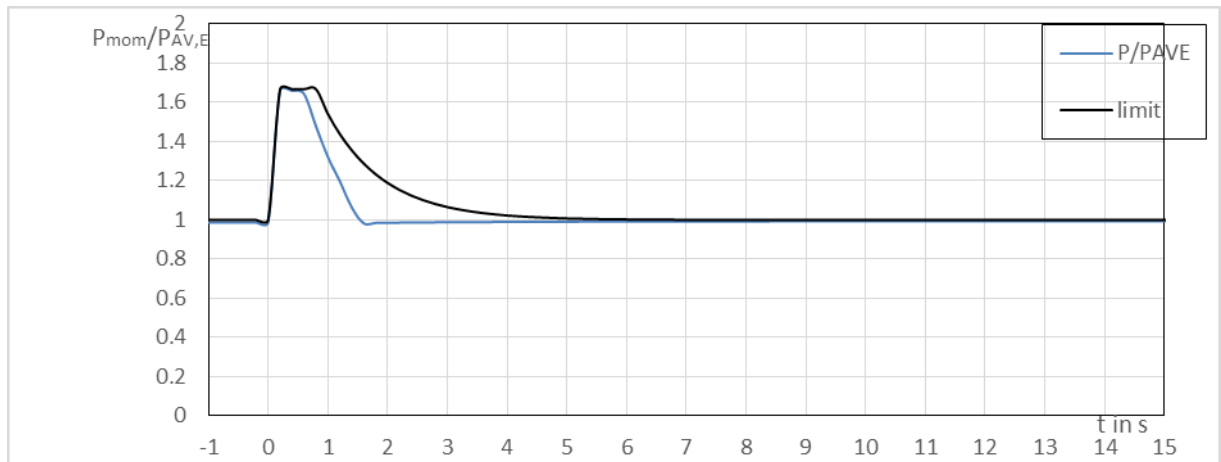

5.8	TABLE: Verification of dynamic network supporting (FVRT)	P
-----	--	---

Test bench diagram:

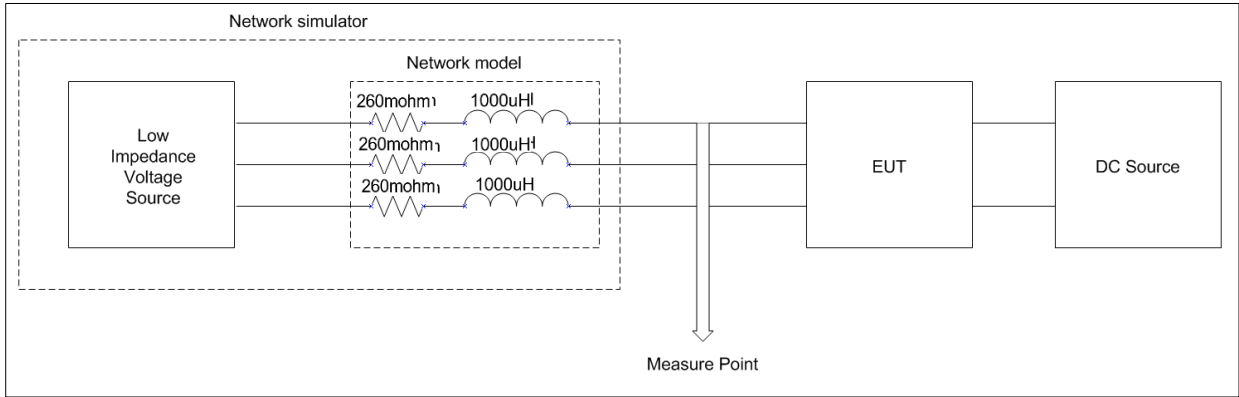

FVRT curve settings:

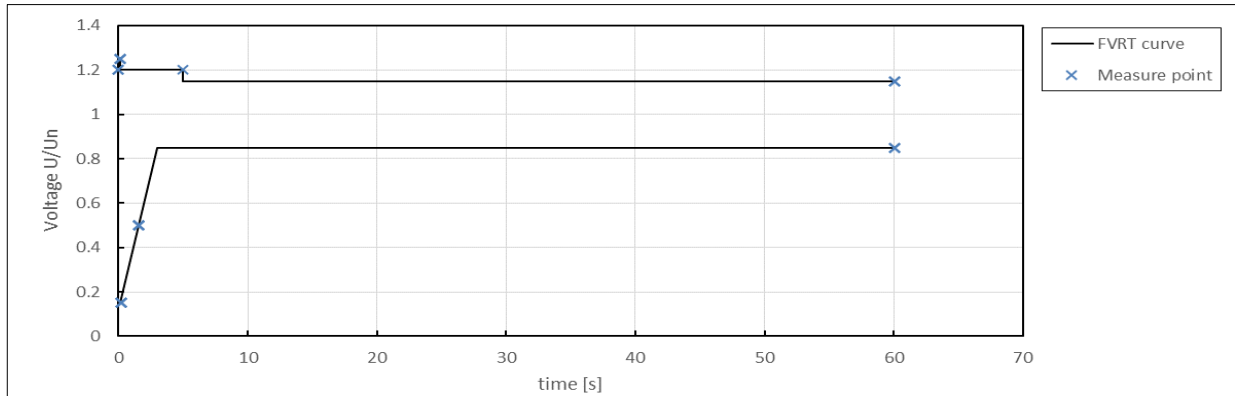

Fault Type	3-phase fault and 2-phase fault
Transformer Type	Dy5
NS protection settings	See table 5.5.7 for detail.
Any auxilliary power supply in fault ride through?	Yes/No
Terminal sequence	For D1: U-L1, V-L2, W-L3 For D2: U-L3, V-L1, W-L2

Test	U/Un [p.u.]	Fault type	Fault duration [ms]	P/Pn [p.u.]	Q/Pn [p.u.]	Test No.	
1	0.15....0.25	A	For 0.15pu ≥ 150 For 0.25pu ≥ 500	1.0	0...±0.1	1.1	
				0.2...0.6		1.2	
				1.0		1.3	
		D1		0.2...0.6		1.4	
				D2		1.0	1.3 (2)
2	0.50....0.60	A	For 0.5pu ≥ 1500 For 0.60pu ≥ 2000	1.0	Max. over-excited	2.1	
				0.2...0.6		2.2	
				1.0		2.3	
		D1		0.2...0.6		2.4	
				A			
3	0.50....0.60	A	For 0.5pu ≥ 1500 For 0.60pu ≥ 2000	1.0	Max. under-excited	3.1	
				0.2...0.6		3.2	
				1.0		3.3	
		D1		0.2...0.6		3.4	
				A			
4	0.85....0.90	A	≥ 60000	1.0	0...±0.1	4.1	
				0.2...0.6		4.2	
				1.0		4.3	
		D1		0.2...0.6		4.4	
				A			
5	1.2....1.25	A	≥ 100	1.0	0...±0.1	5.1	
				0.2...0.6		5.2	
				1.0		5.3	
		D1		0.2...0.6		5.4	
				D2		1.0	5.3 (2)
6	1.15...1.20	A	≥ 5000	1.0	0...±0.1	6.1	
				0.2...0.6		6.2	
				1.0		6.3	
		D1		0.2...0.6		6.4	
				A			
7	1.10...1.15	A	≥ 60000	1.0	0...±0.1	7.1	
				0.2...0.6		7.2	
				1.0		7.3	
		D1		0.2...0.6		7.4	
				A			

Condition	Measurement
-----------	-------------

	No.	Parameter	Phase ref.	Time ref.	unit	
General Info.	0	Test number	--	--	--	1.1
	1	Date	--	--	dd.mm.yyyy	28.07.2025
	2	Time (start of test)	--	--	hh:mm:ss.f	13:47:05
	3	Fault type (phase)	--	--		3-phase fault
	4	Setting voltage depth	Line to line	--	p.u.	0.15
	5	Setting dip duration		--		199
	6	Point of fault entry	Total	--	ms	0
	7	Point of fault clearance	Total	--	ms	199
	8	Fault duration in empty load test	Total	--	ms	199
	9	Voltage depth/height in empty load test	Total	t1+100ms to t2 and t1-10s to t1	p.u.	0.15
10	Pos.		p.u.		0.15	
Before dip <t1	11	Voltage	Line to neutral	t1-100s to t1	p.u.	1.00
	12	Current	Pos.	t1-500ms to t1-100ms	p.u.	0.99
	13	Active power	Total	t1-10s to t1	p.u.	0.99
	14		Pos.			0.99
	15	Reactive power	Total	t1-10s to t1	p.u.	0.01
	16		Pos.			0.01
	17	Cos ϕ	--	t1-10s to t1	--	1.000
During dip t1 to t2	18	Voltage	Line to neutral	t1+100ms to t2-20ms	p.u.	0.15
	19	Line current	Phase 1	t1+60ms	p.u.	0.00
	20		Phase 2			0.00
	21		Phase 3			0.00
	22	Line current	Phase 1	t1+100ms	p.u.	0.00
	23		Phase 2			0.00
	24		Phase 3			0.00
	25	Active power	Total	t1+100ms to t2-20ms	p.u.	0.00
26	Pos.		0.00			
After dip > t2	27	Voltage	Line to neutral	t2+3s to t2+10s	p.u.	1.00
	28	Active power	Total	t2+3s to t2+10s	p.u.	0.99
	29		Pos.			0.99
	39	Active power rising time	Pos.	--	s	0.049
	31	Reactive power	Total	t2+3s to t2+10s	p.u.	0.01
	32		Pos.			0.01
	33	Reactive power rising time	Pos.	--	s	N/A
	34	PGU does not disconnect from grid till 60s after fault	--	t2 to t2+60s	Yes / No	No

Test No. 1.1 idle test

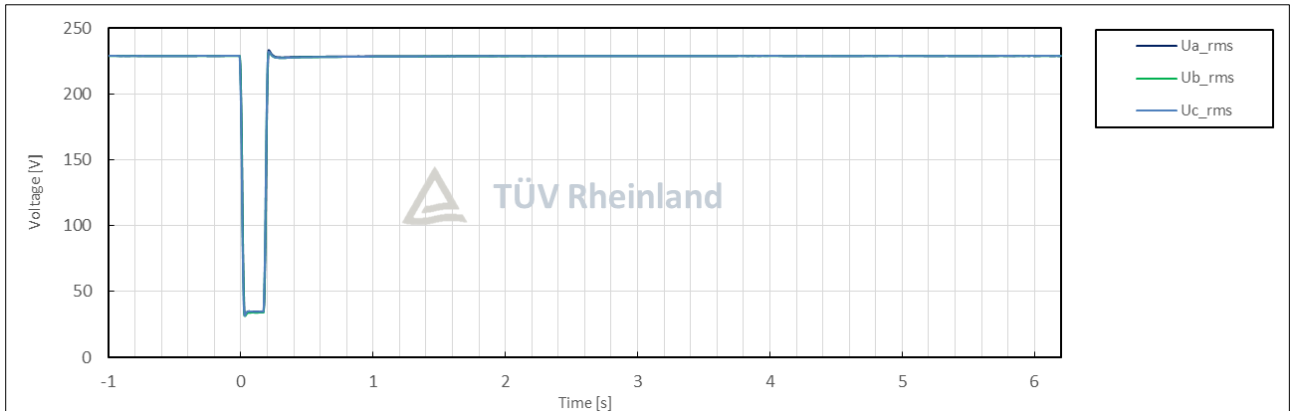
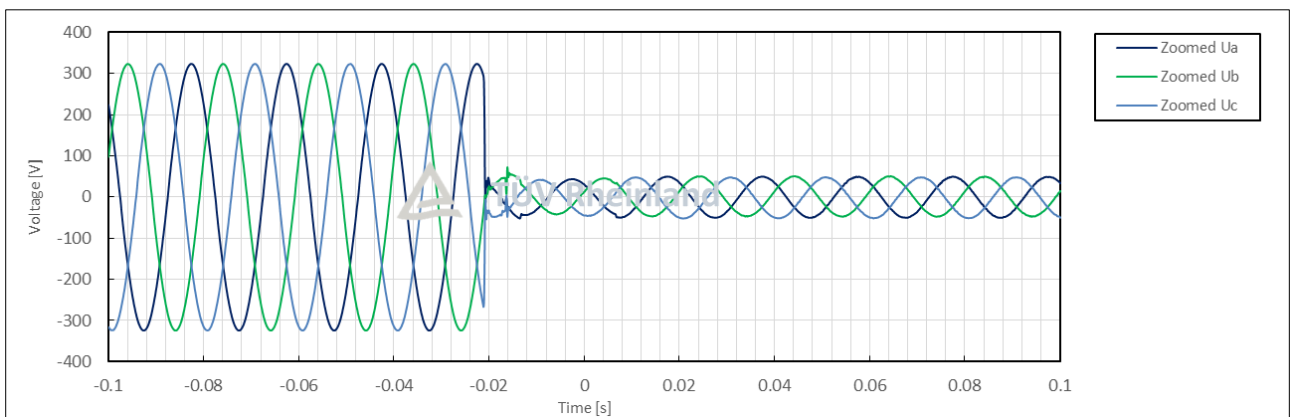
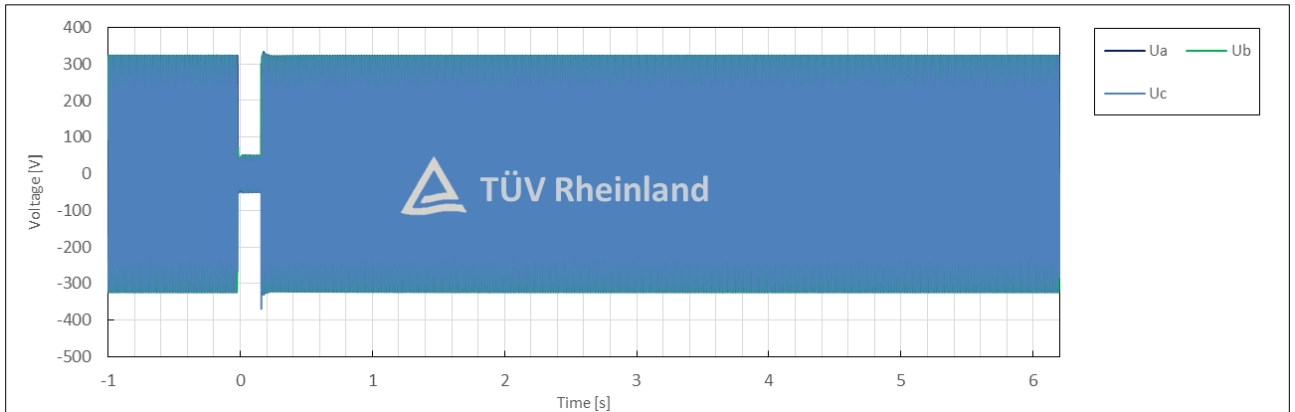

Test No. 1.1 with PGU

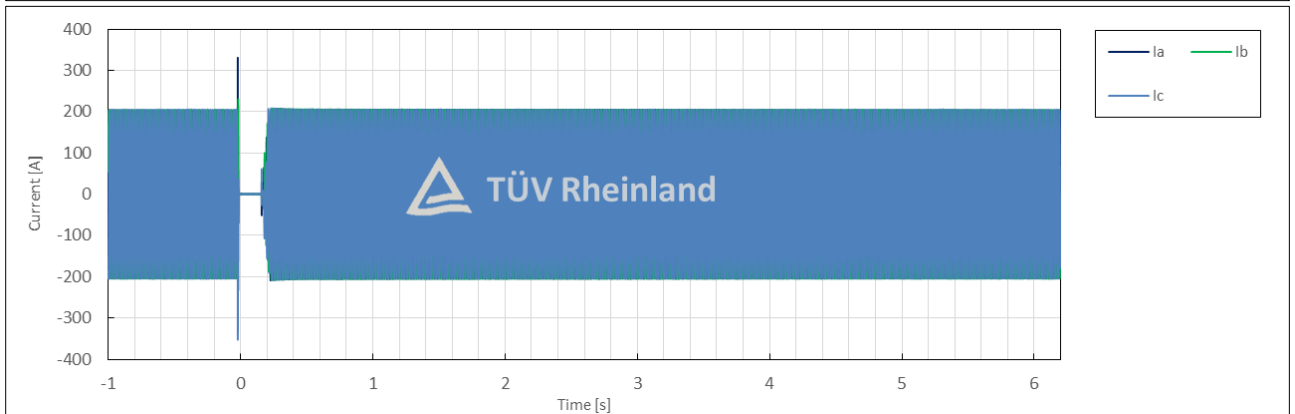
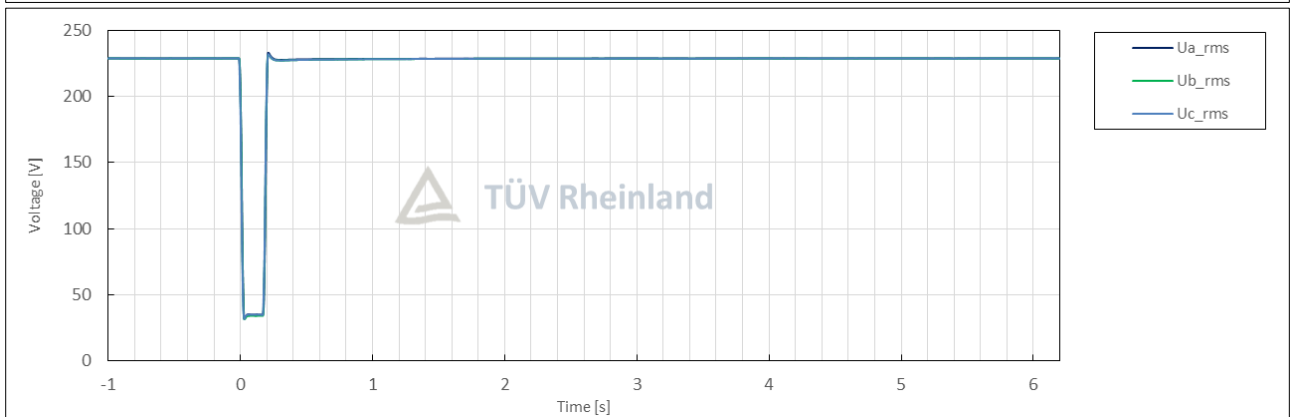
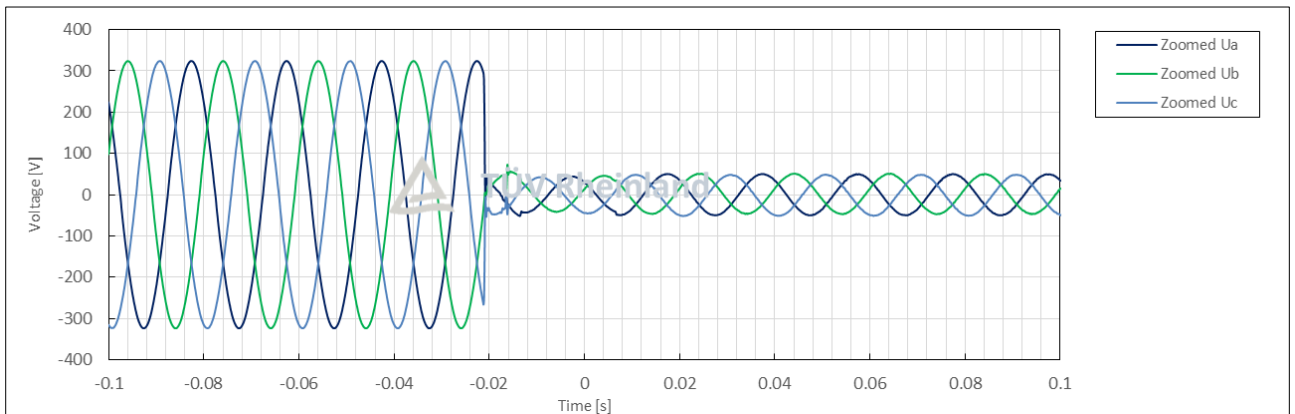
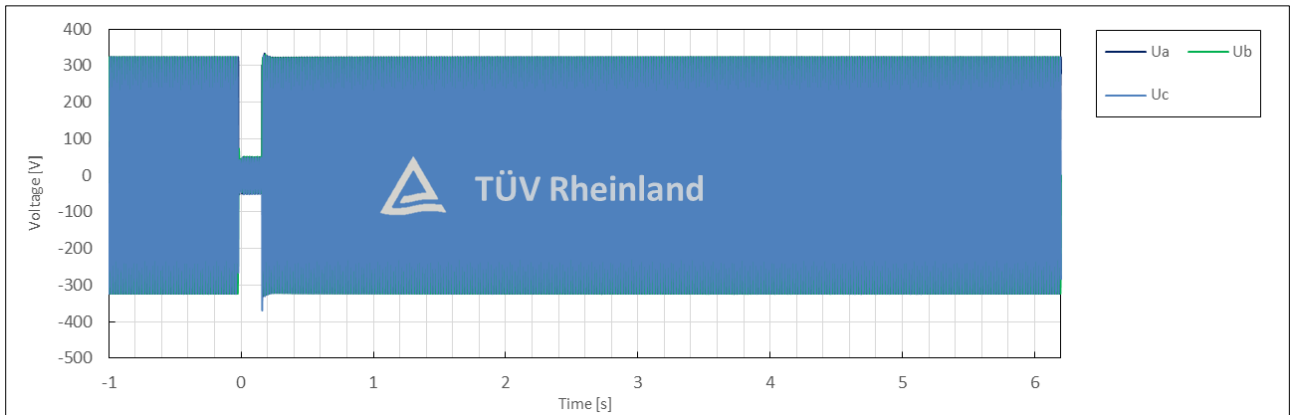

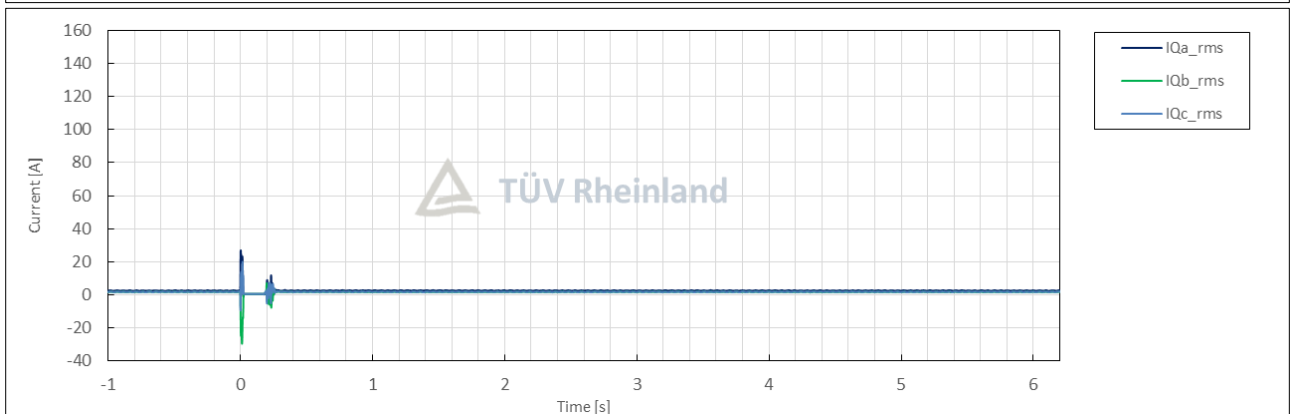
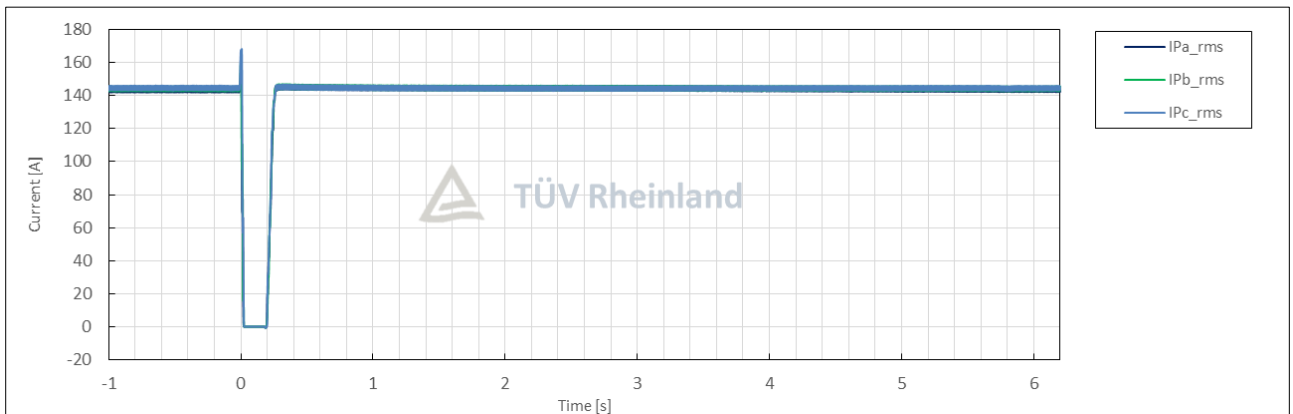
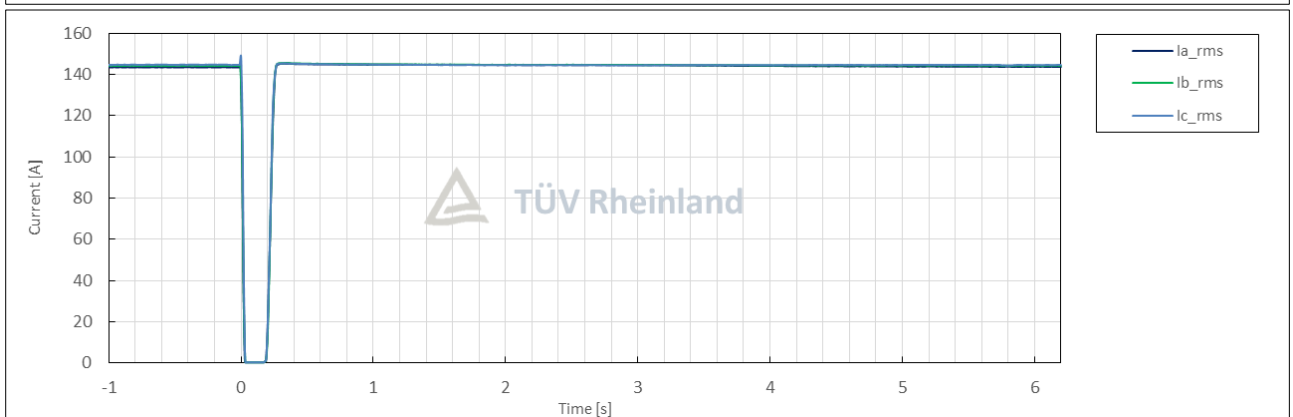
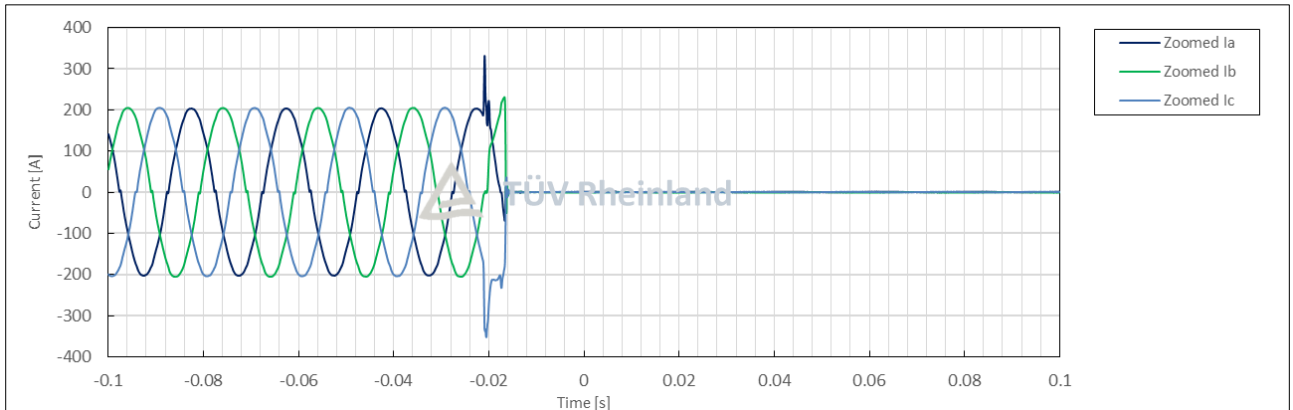

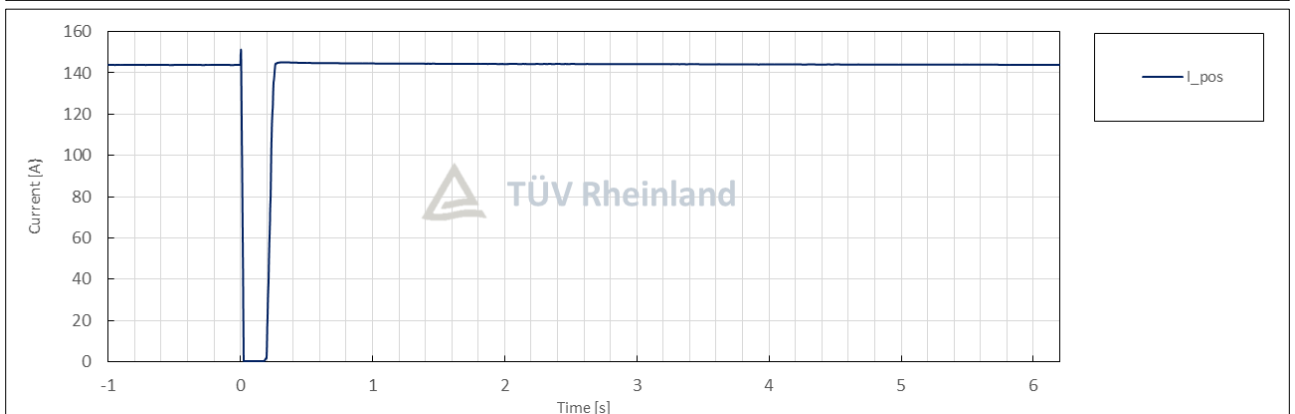
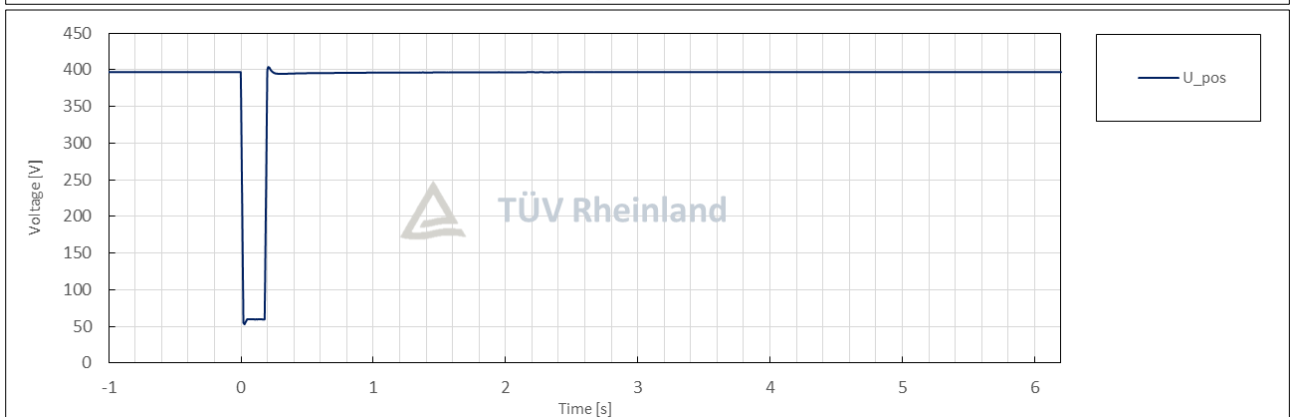
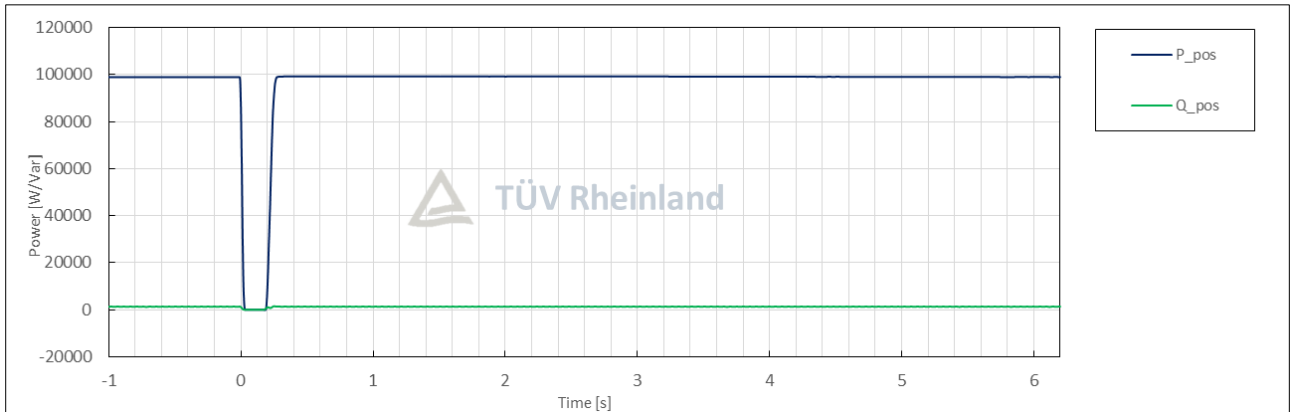

Condition						Measurement
No.	Parameter	Phase ref.	Time ref.	unit		
General Info.	0	Test number	--	--	--	1.2
	1	Date	--	--	dd.mm.yyyy	28.07.2025
	2	Time (start of test)	--	--	hh:mm:ss.f	13:48:16
	3	Fault type (phase)	--	--		3-phase fault
	4	Setting voltage depth	Line to line	--	p.u.	0.15
	5	Setting dip duration		--		199
	6	Point of fault entry	Total	--	ms	0
	7	Point of fault clearance	Total	--	ms	199
	8	Fault duration in empty load test	Total	--	ms	199
	9	Voltage depth/height in empty load test	Total	t1+100ms to t2 and t1-10s to t1	p.u.	0.15
10	Pos.		p.u.		0.15	
Before dip <t1	11	Voltage	Line to neutral	t1-100s to t1	p.u.	0.99
	12	Current	Pos.	t1-500ms to t1-100ms	p.u.	0.30
	13	Active power	Total	t1-10s to t1	p.u.	0.30
	14		Pos.			0.30
	15	Reactive power	Total	t1-10s to t1	p.u.	0.00
	16		Pos.			0.00
17	Cos ϕ	--	t1-10s to t1	--	1.000	
During dip t1 to t2	18	Voltage	Line to neutral	t1+100ms to t2-20ms	p.u.	0.15
	19	Line current	Phase 1	t1+60ms	p.u.	0.00
	20		Phase 2			0.00
	21		Phase 3			0.00
	22	Line current	Phase 1	t1+100ms	p.u.	0.00
	23		Phase 2			0.00
	24		Phase 3			0.00
	25	Active power	Total	t1+100ms to t2-20ms	p.u.	0.00
26	Pos.		0.00			
After dip > t2	27	Voltage	Line to neutral	t2+3s to t2+10s	p.u.	0.99
	28	Active power	Total	t2+3s to t2+10s	p.u.	0.30
	29		Pos.			0.30
	39	Active power rising time	Pos.	--	s	0.022
	31	Reactive power	Total	t2+3s to t2+10s	p.u.	0.00
	32		Pos.			0.00
	33	Reactive power rising time	Pos.	--	s	N/A
34	PGU does not disconnect from grid till 60s after fault	--	t2 to t2+60s	Yes / No	No	

Test No. 1.2 idle test

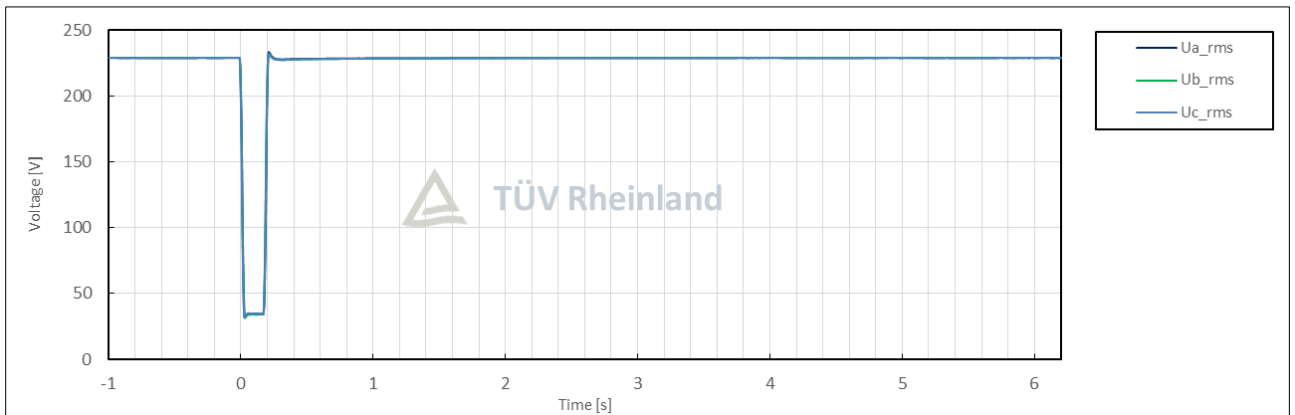
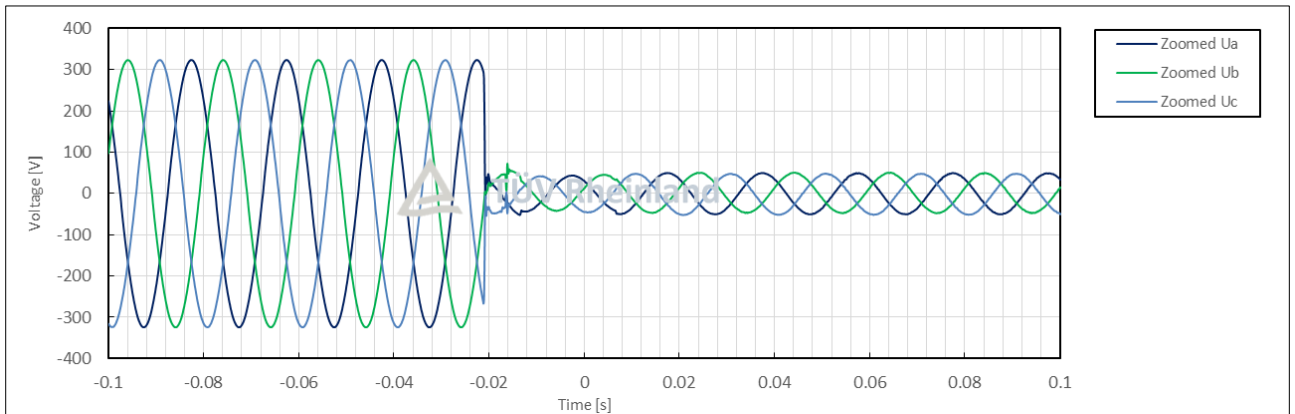
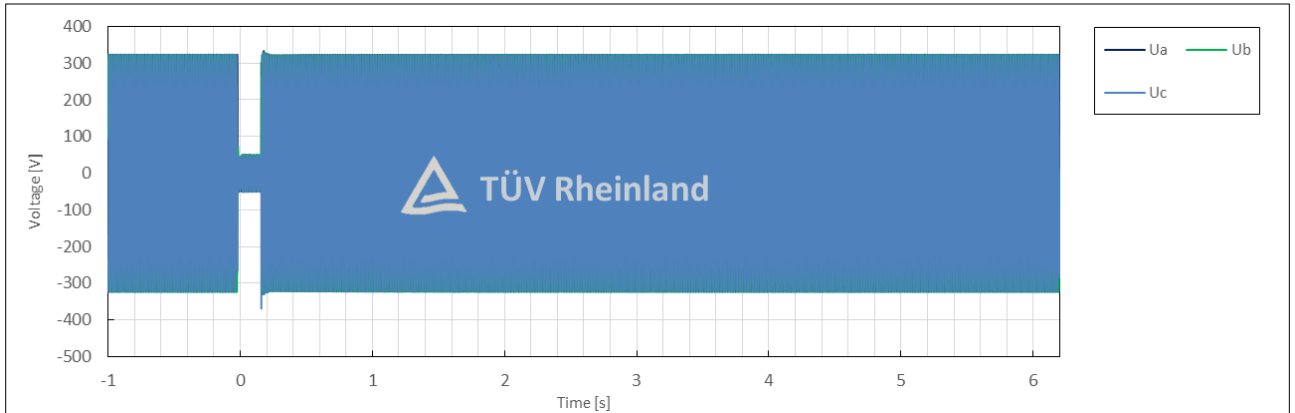

Test No. 1.2 with PGU

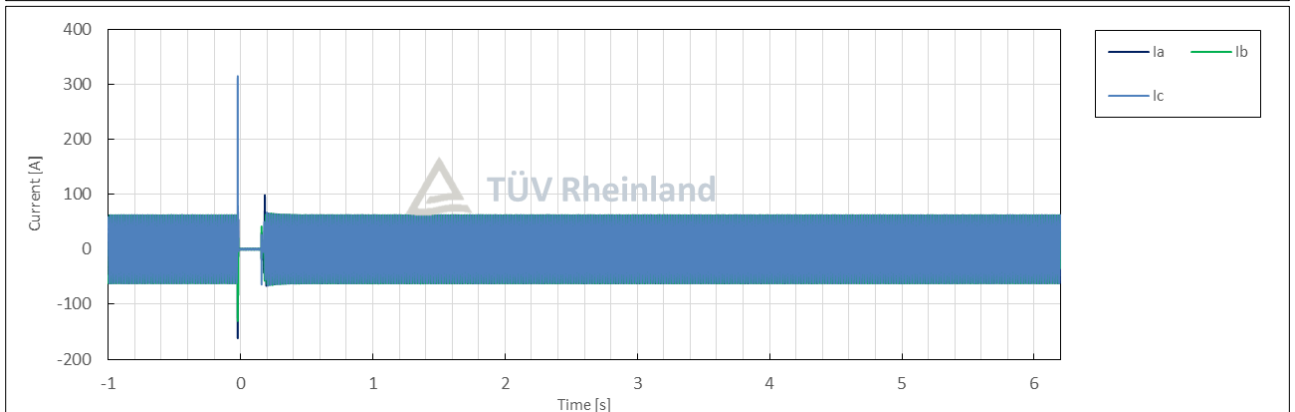
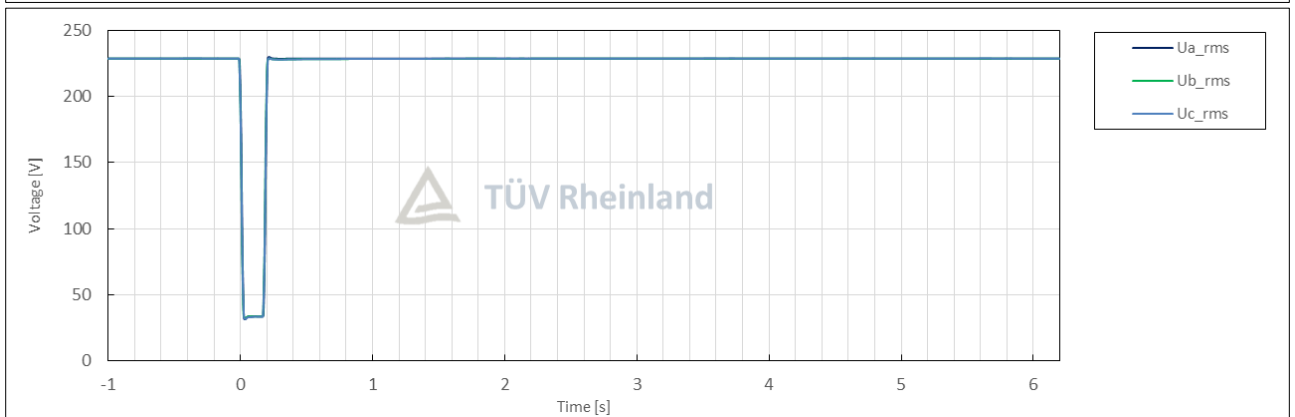
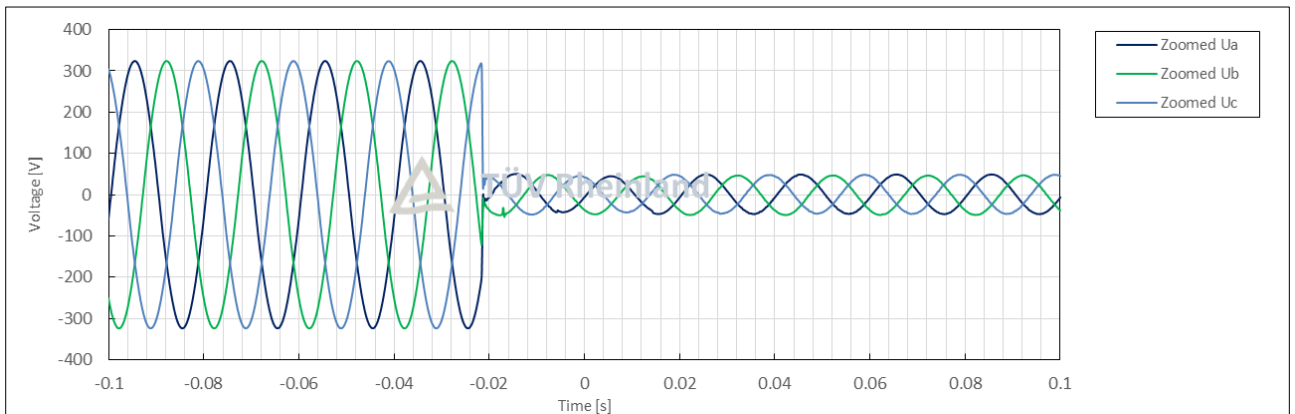
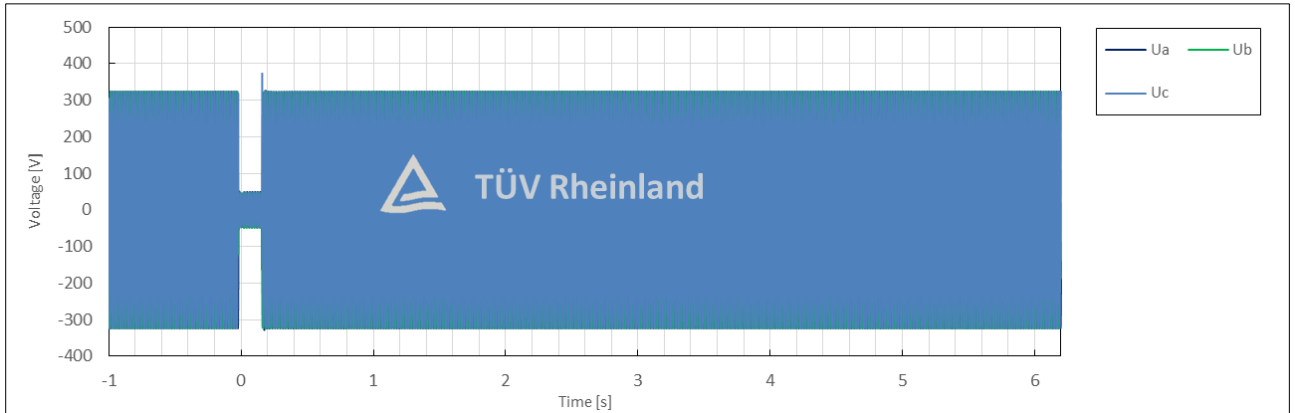

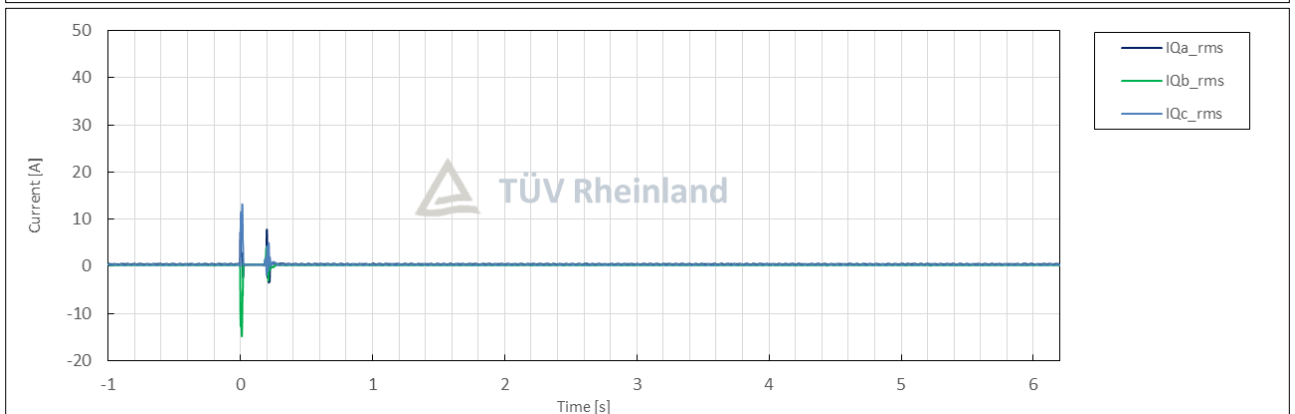
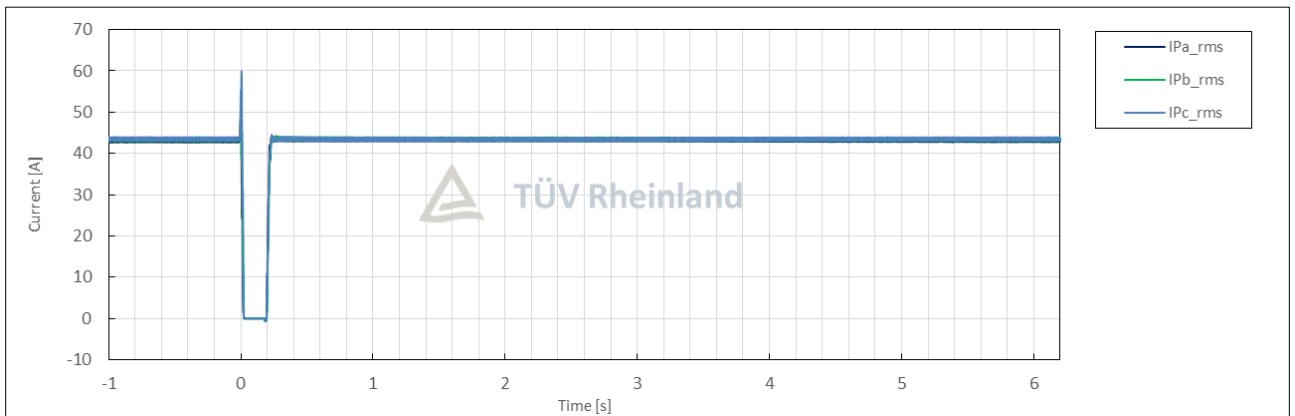
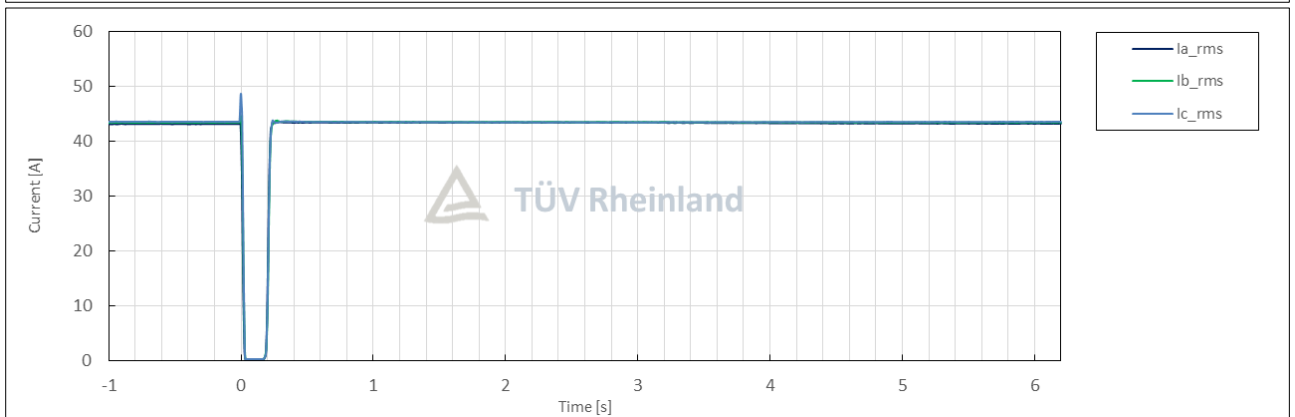
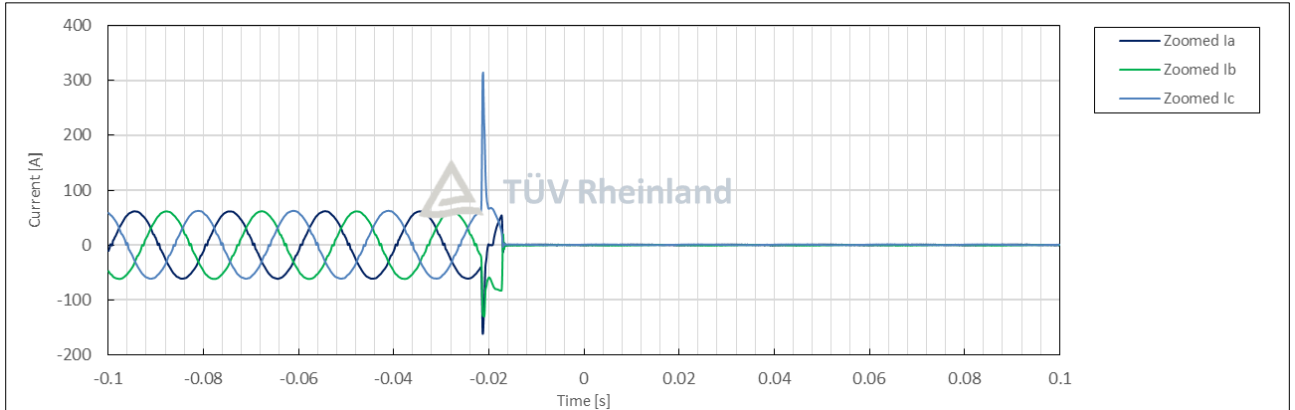

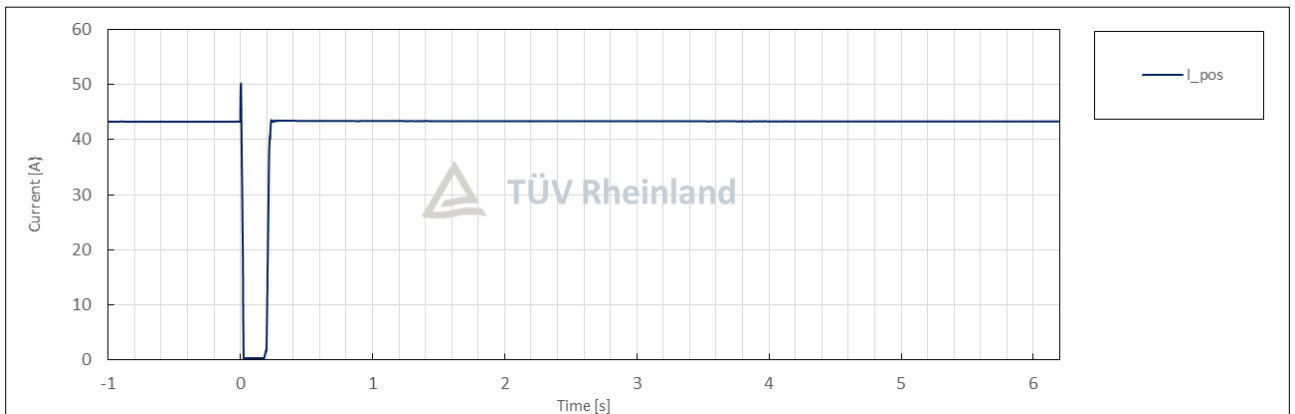
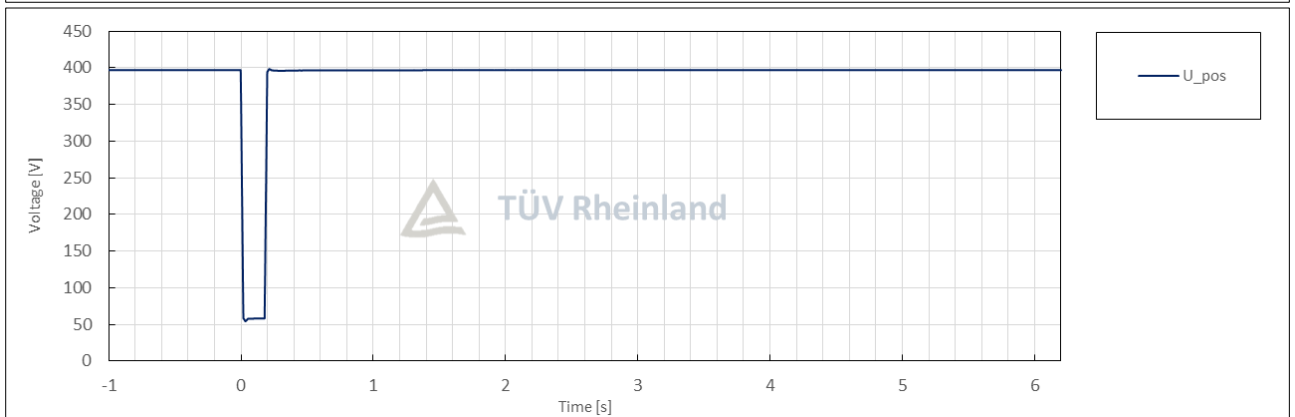
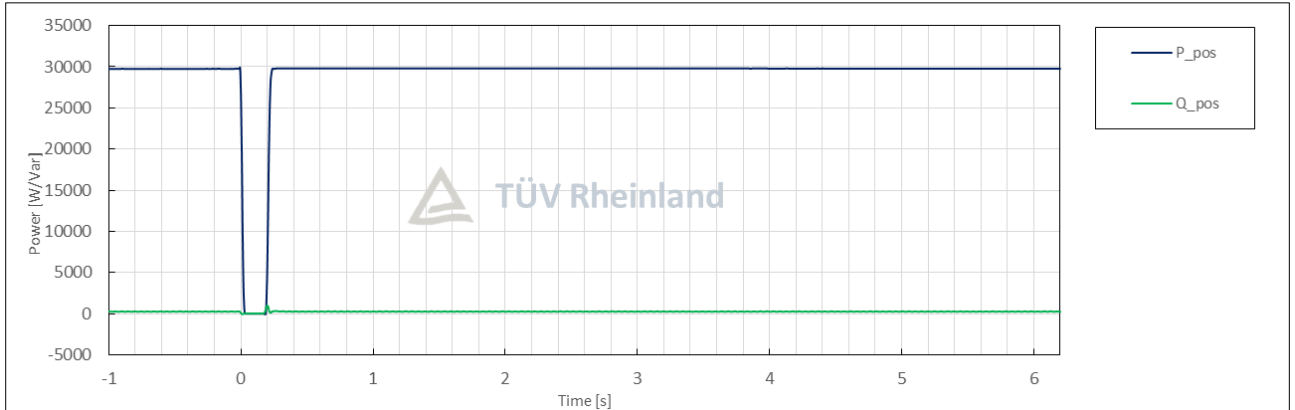

Condition						Measurement
No.	Parameter	Phase ref.	Time ref.	unit		
General Info.	0	Test number	--	--	--	1.3
	1	Date	--	--	dd.mm.yyyy	28.07.2025
	2	Time (start of test)	--	--	hh:mm:ss.f	13:49:39
	3	Fault type (phase)	--	--		2-phase fault
	4	Setting voltage depth	Line to line	--	p.u.	0.16
	5	Setting dip duration		--		196
	6	Point of fault entry	Total	--	ms	0
	7	Point of fault clearance	Total	--	ms	196
	8	Fault duration in empty load test	Total	--	ms	196
	9	Voltage depth/height in empty load test	Total	t1+100ms to t2 and t1-10s to t1	p.u.	0.16
	10		Pos.		p.u.	0.43
Before dip <t1	11	Voltage	Line to neutral	t1-100s to t1	p.u.	1.00
	12	Current	Pos.	t1-500ms to t1-100ms	p.u.	0.99
	13	Active power	Total	t1-10s to t1	p.u.	0.99
	14		Pos.			0.99
	15	Reactive power	Total	t1-10s to t1	p.u.	0.01
	16		Pos.			0.01
	17	Cos ϕ	--	t1-10s to t1	--	1.000
During dip t1 to t2	18	Voltage	Line to neutral	t1+100ms to t2-20ms	p.u.	0.16
	19	Line current	Phase 1	t1+60ms	p.u.	0.01
	20		Phase 2			0.00
	21		Phase 3			0.01
	22	Line current	Phase 1	t1+100ms	p.u.	0.01
	23		Phase 2			0.00
	24		Phase 3			0.01
	25	Active power	Total	t1+100ms to t2-20ms	p.u.	0.00
	26		Pos.			0.00
After dip > t2	27	Voltage	Line to neutral	t2+3s to t2+10s	p.u.	1.00
	28	Active power	Total	t2+3s to t2+10s	p.u.	0.99
	29		Pos.			0.99
	30	Active power rising time	Pos.	--	s	0.075
	31	Reactive power	Total	t2+3s to t2+10s	p.u.	0.01
	32		Pos.			0.01
	33	Reactive power rising time	Pos.	--	s	N/A
	34	PGU does not disconnect from grid till 60s after fault	--	t2 to t2+60s	Yes / No	No

Test No. 1.3 idle test

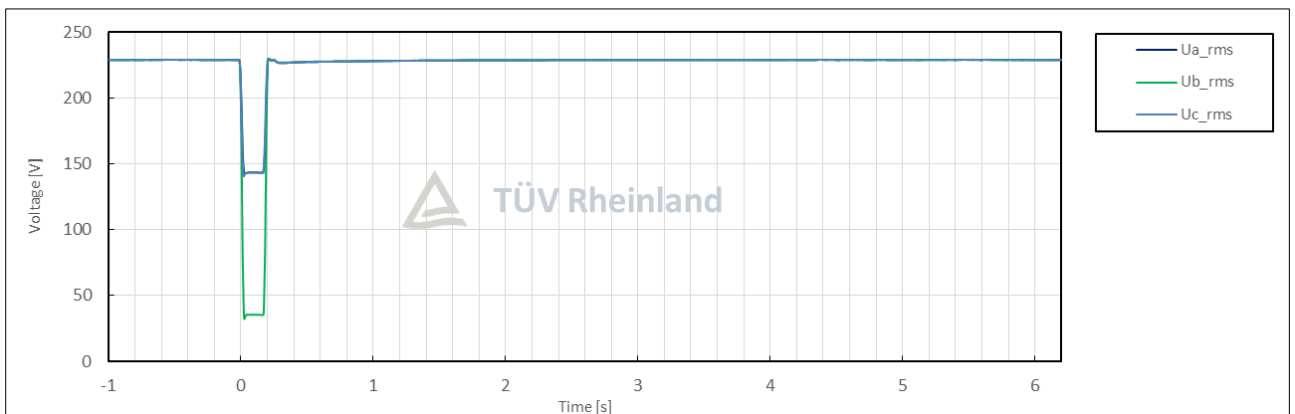
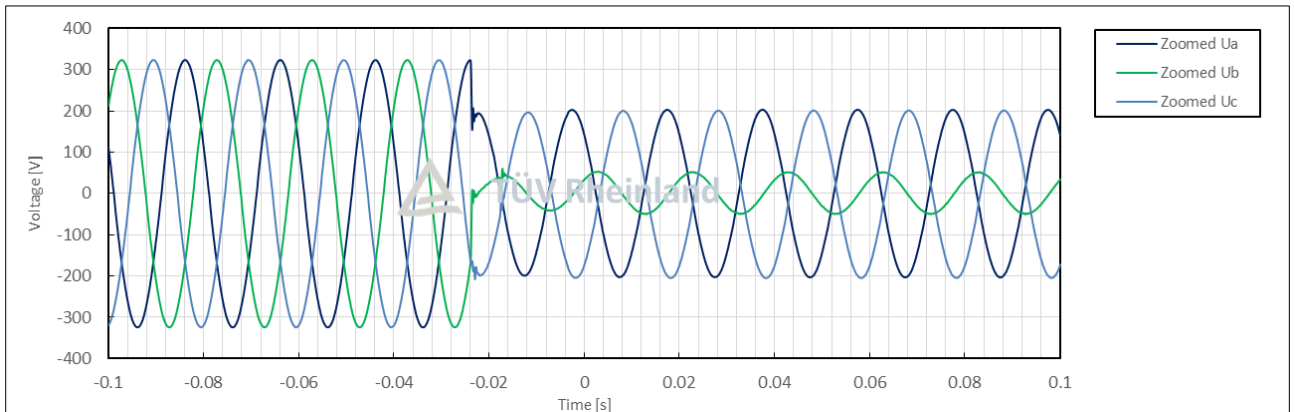
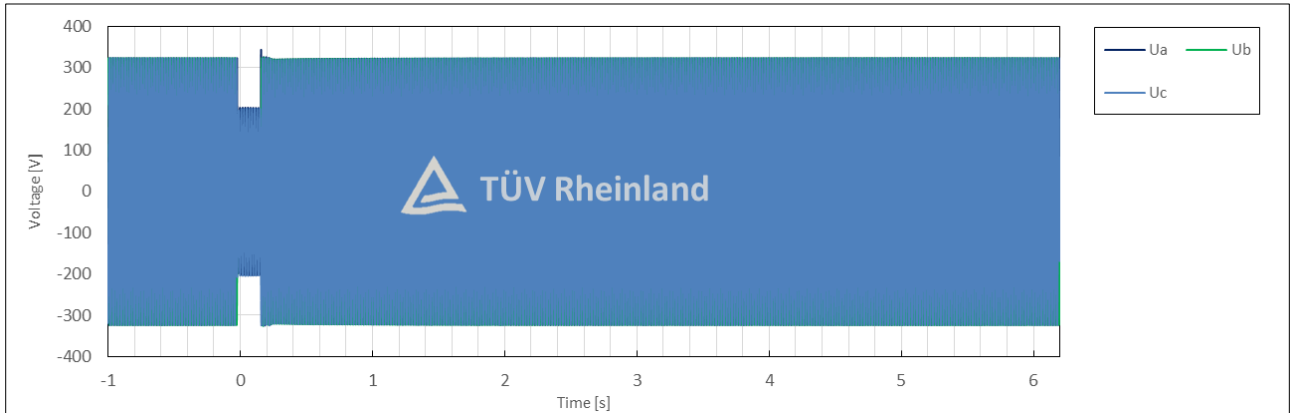

Test No. 1.3 with PGU

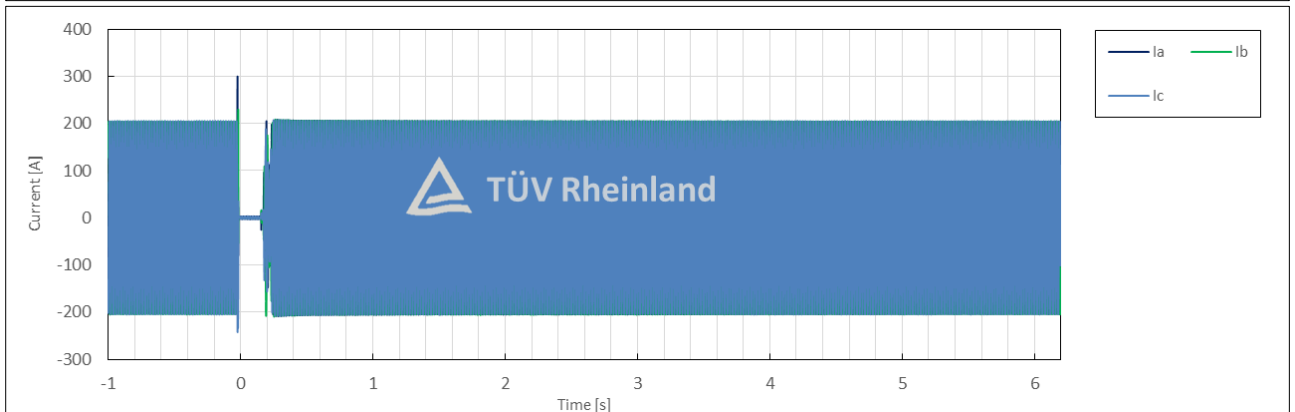
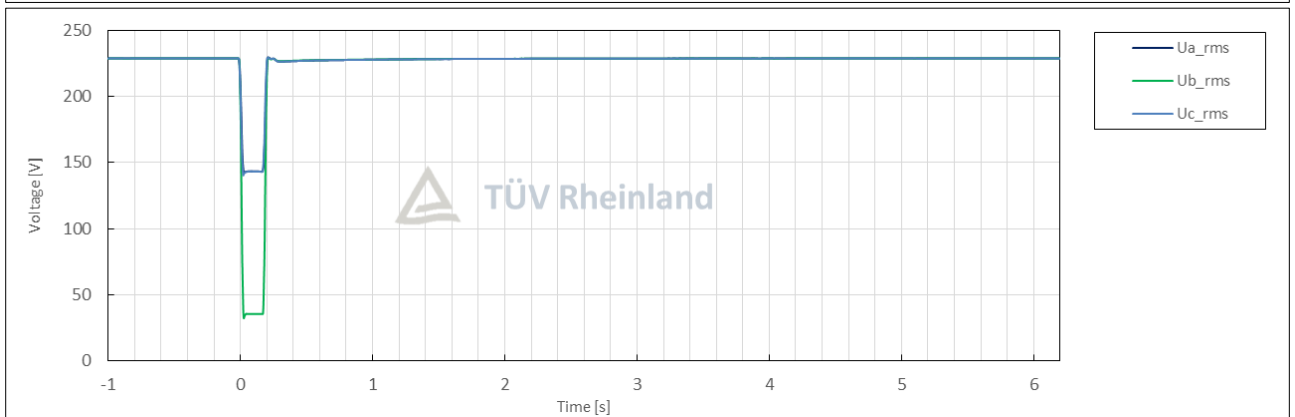
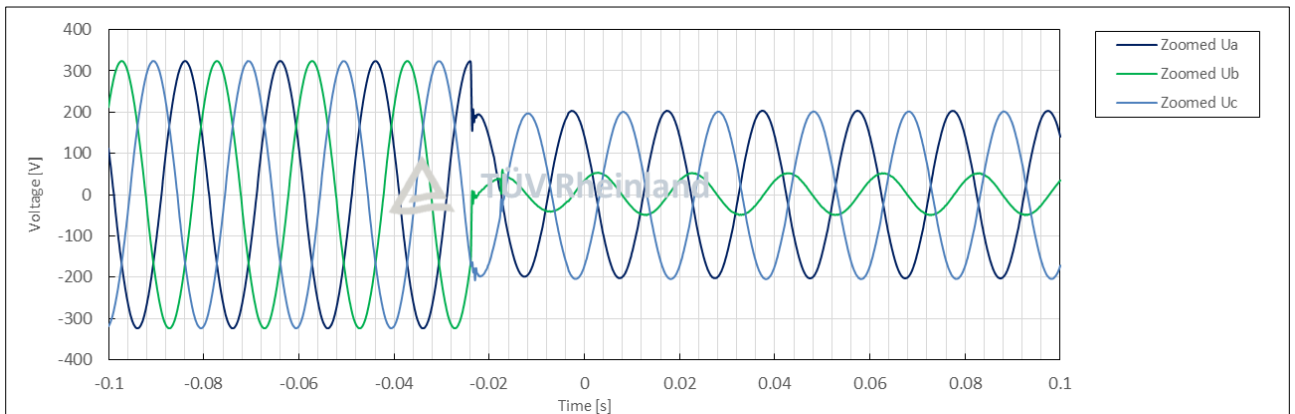
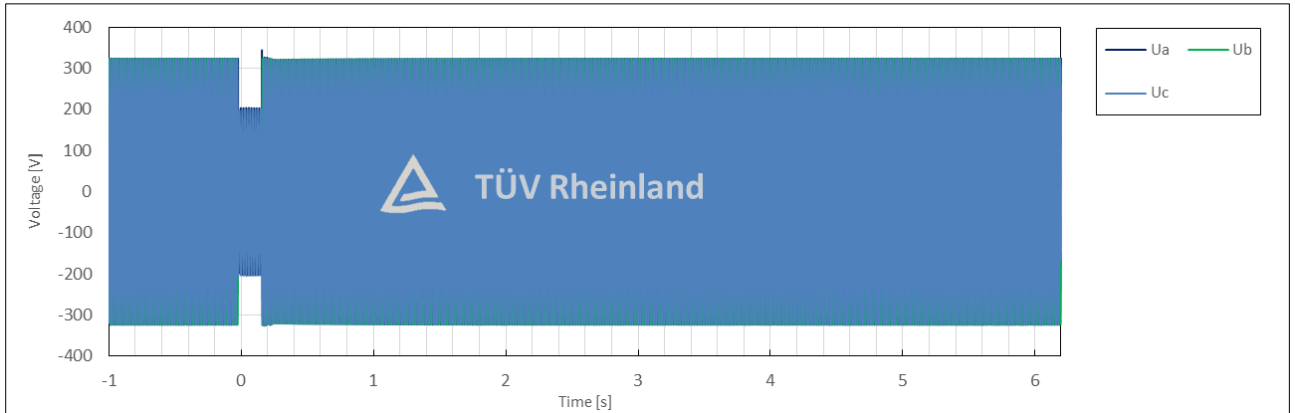

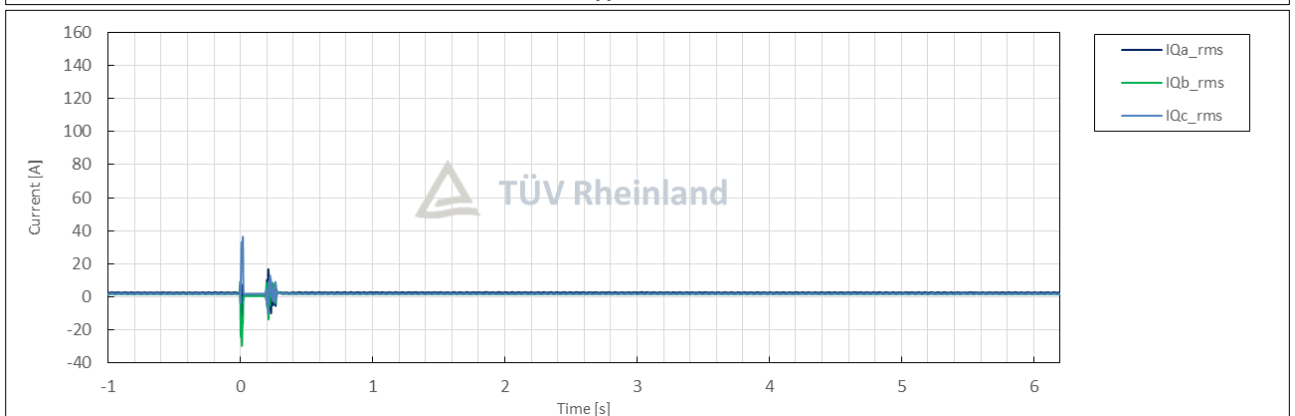
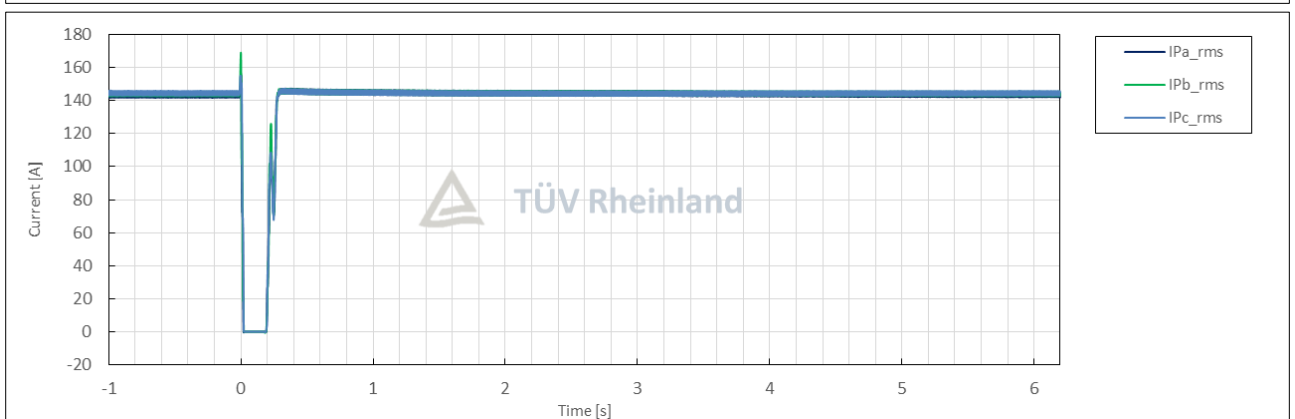
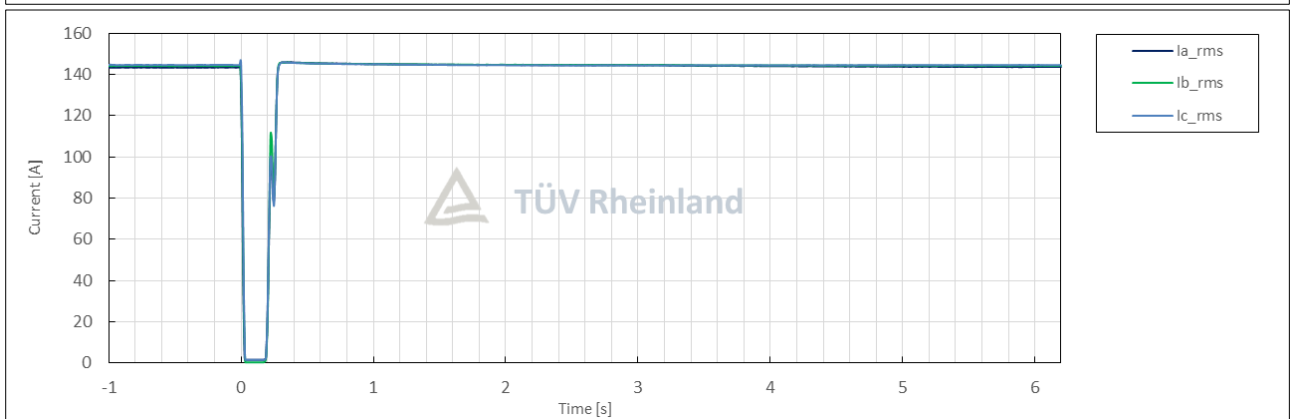
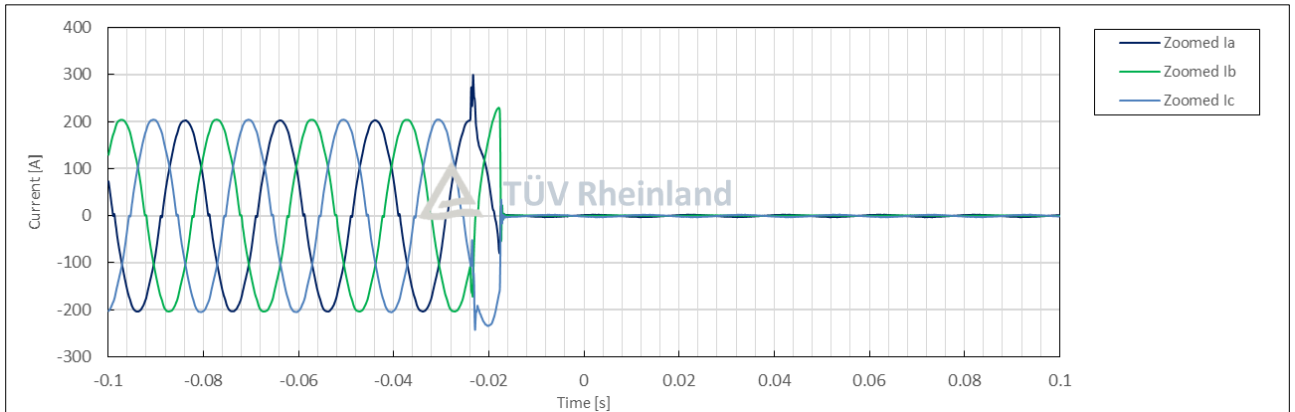

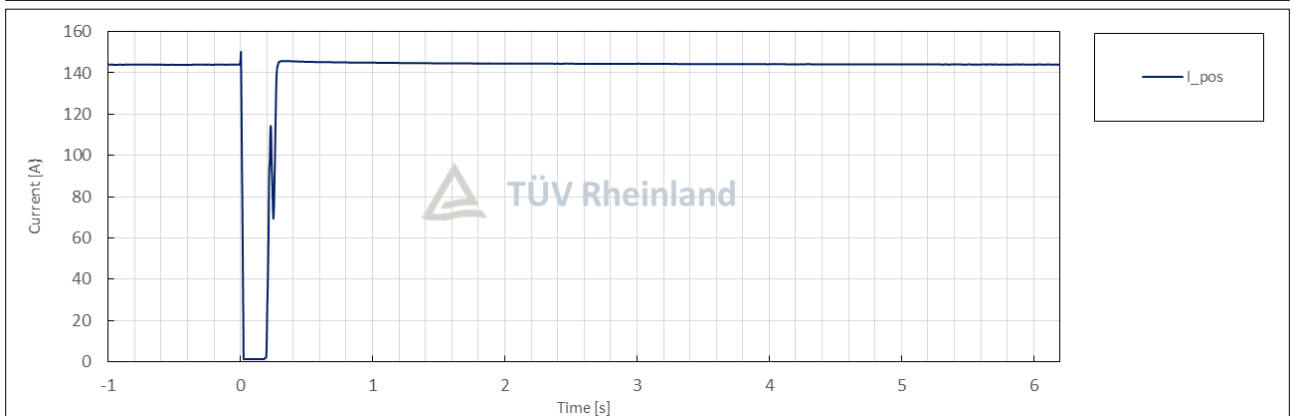
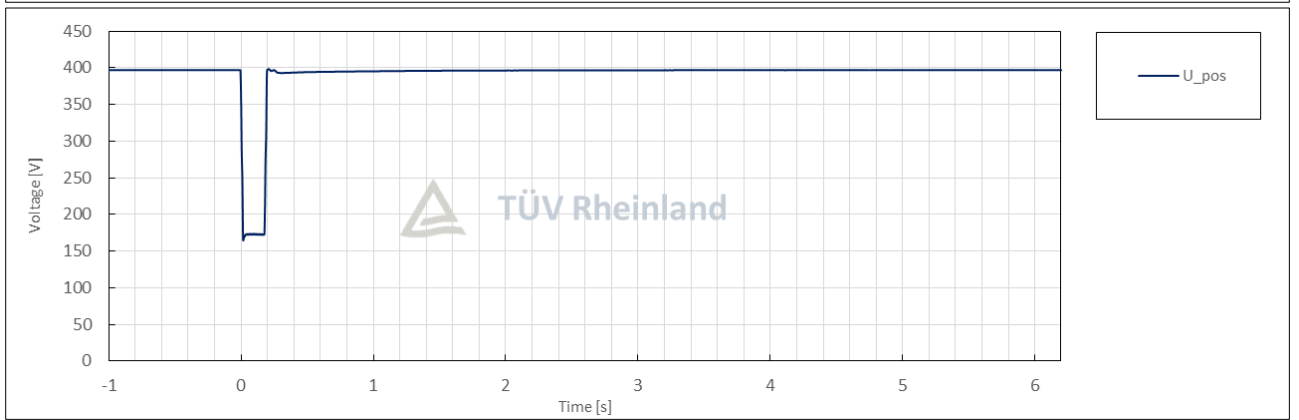
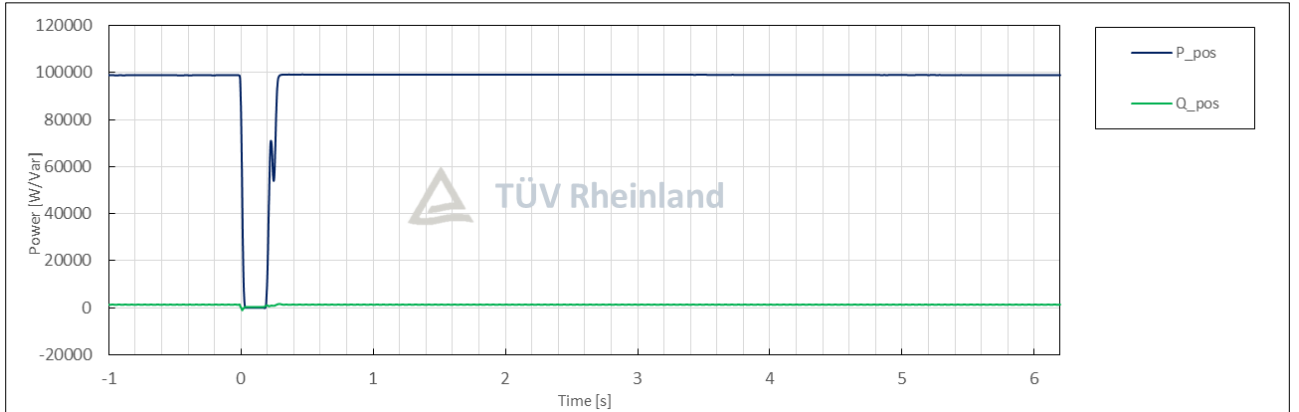

Condition						Measurement
No.	Parameter	Phase ref.	Time ref.	unit		
General Info.	0	Test number	--	--	--	1.3(D2)
	1	Date	--	--	dd.mm.yyyy	28.07.2025
	2	Time (start of test)	--	--	hh:mm:ss.f	13:49:25
	3	Fault type (phase)	--	--		2-phase fault
	4	Setting voltage depth	Line to line	--	p.u.	0.16
	5	Setting dip duration		--		196
	6	Point of fault entry	Total	--	ms	0
	7	Point of fault clearance	Total	--	ms	196
	8	Fault duration in empty load test	Total	--	ms	196
	9	Voltage depth/height in empty load test	Total	t1+100ms to t2 and t1-10s to t1	p.u.	0.16
10	Pos.		p.u.		0.43	
Before dip <t1	11	Voltage	Line to neutral	t1-100s to t1	p.u.	1.00
	12	Current	Pos.	t1-500ms to t1-100ms	p.u.	0.99
	13	Active power	Total	t1-10s to t1	p.u.	0.99
	14		Pos.			0.99
	15	Reactive power	Total	t1-10s to t1	p.u.	0.01
	16		Pos.			0.01
17	Cos ϕ	--	t1-10s to t1	--	1.000	
During dip t1 to t2	18	Voltage	Line to neutral	t1+100ms to t2-20ms	p.u.	0.16
	19	Line current	Phase 1	t1+60ms	p.u.	0.00
	20		Phase 2			0.01
	21		Phase 3			0.01
	22	Line current	Phase 1	t1+100ms	p.u.	0.00
	23		Phase 2			0.01
	24		Phase 3			0.01
	25	Active power	Total	t1+100ms to t2-20ms	p.u.	0.00
26	Pos.		0.00			
After dip > t2	27	Voltage	Line to neutral	t2+3s to t2+10s	p.u.	1.00
	28	Active power	Total	t2+3s to t2+10s	p.u.	0.99
	29		Pos.			0.99
	39	Active power rising time	Pos.	--	s	0.053
	31	Reactive power	Total	t2+3s to t2+10s	p.u.	0.01
	32		Pos.			0.01
	33	Reactive power rising time	Pos.	--	s	N/A
34	PGU does not disconnect from grid till 60s after fault	--	t2 to t2+60s	Yes / No	No	

Test No. 1.3(D2) idle test

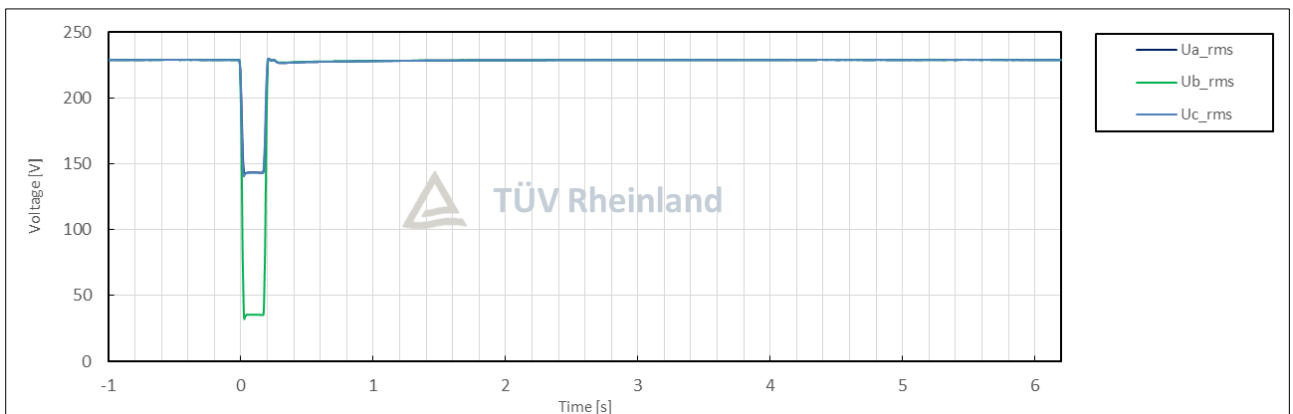
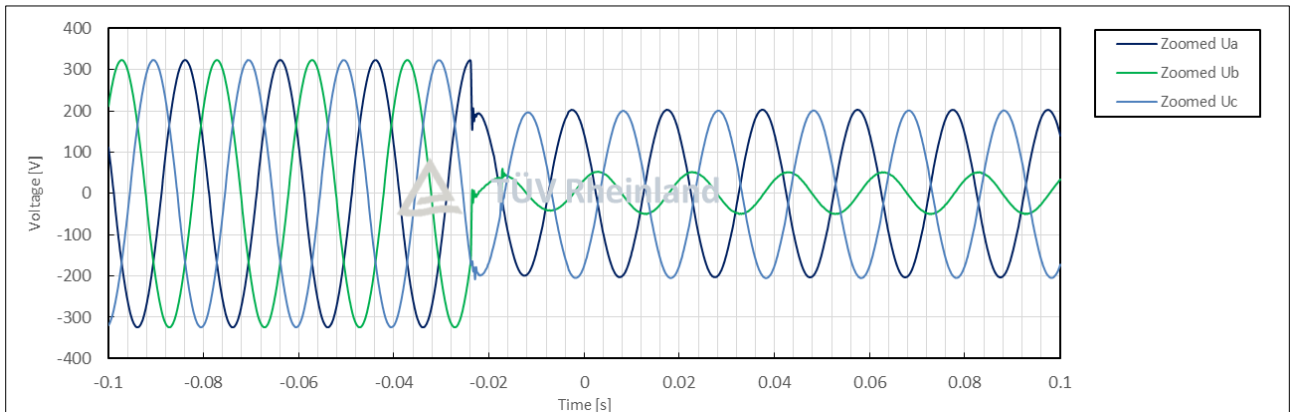
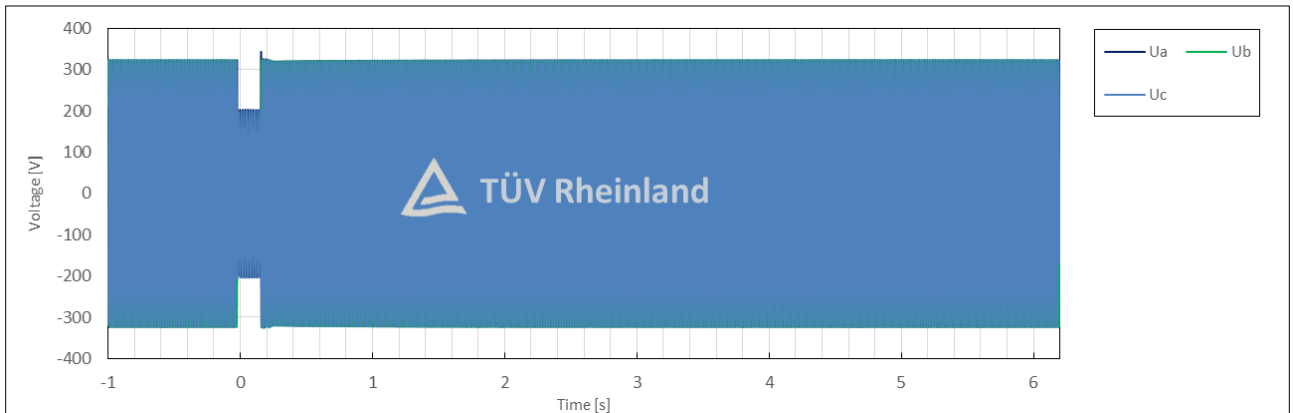

Test No. 1.3(D2) with PGU

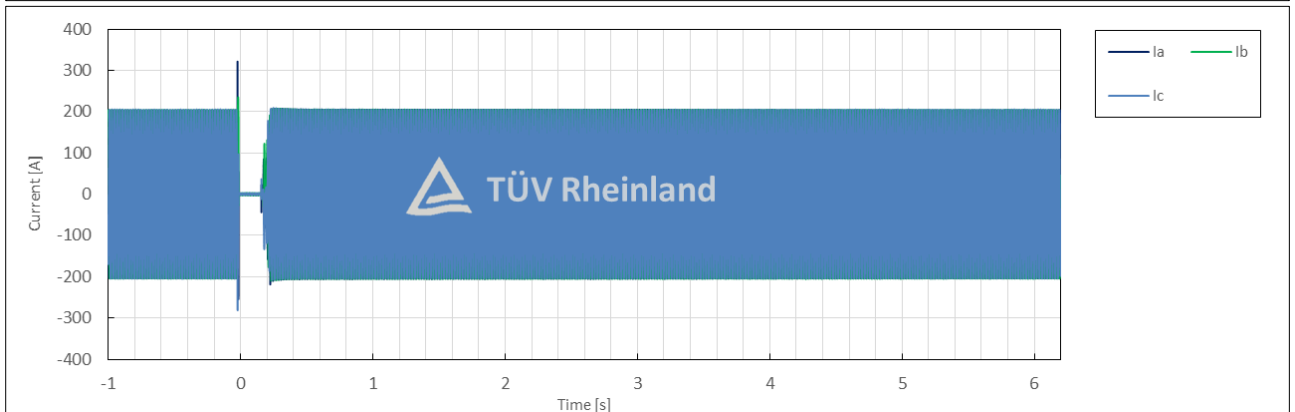
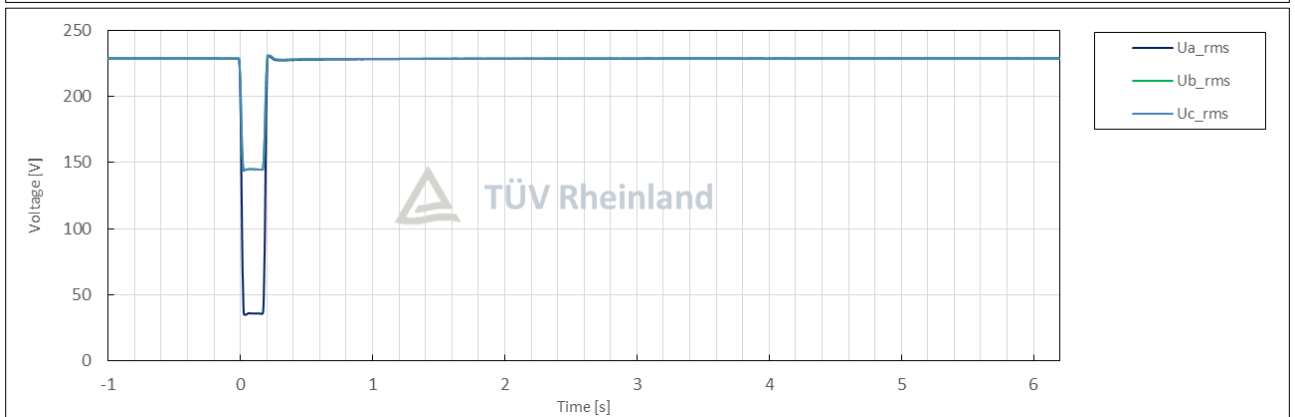
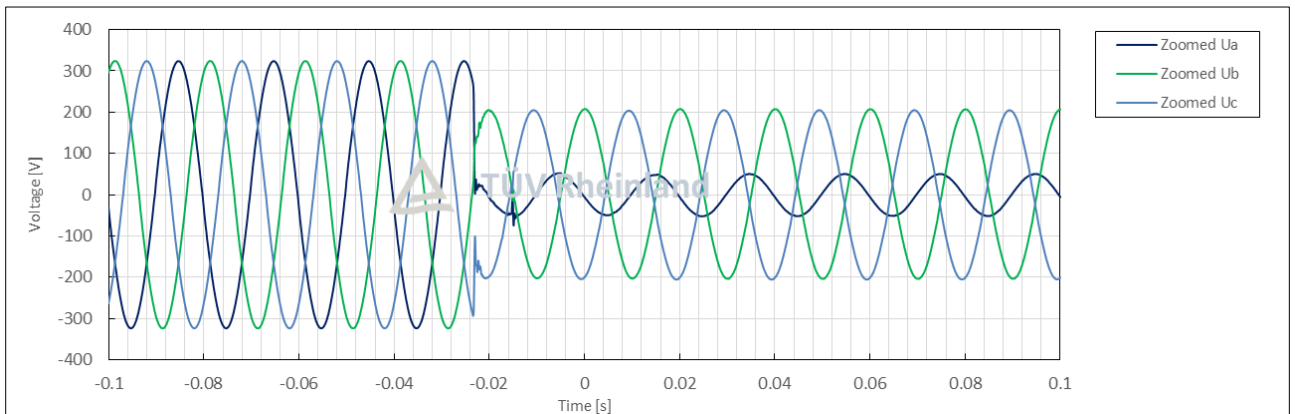
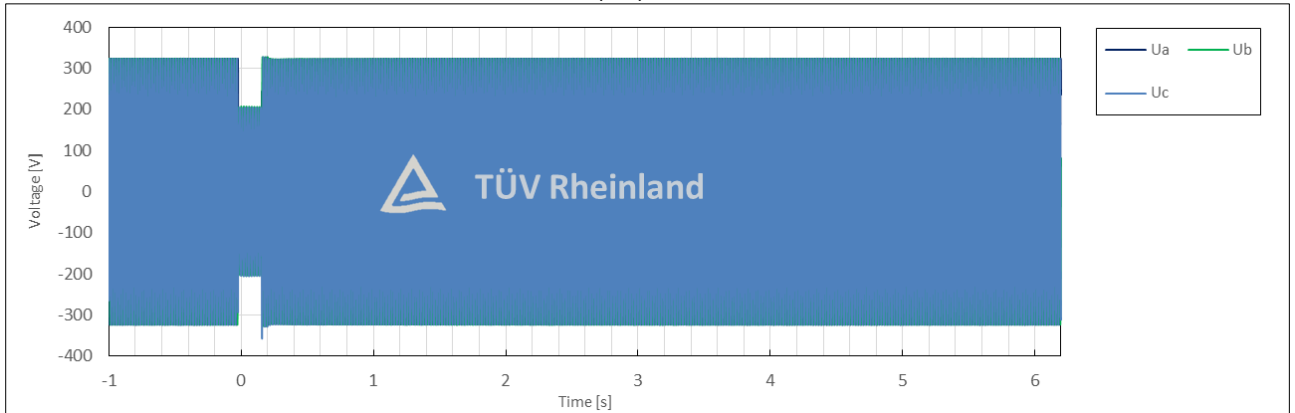

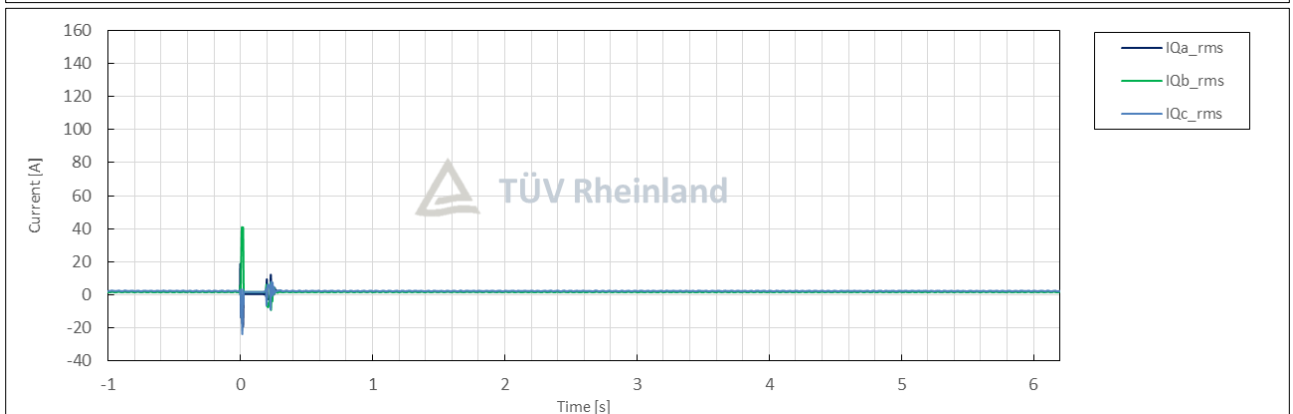
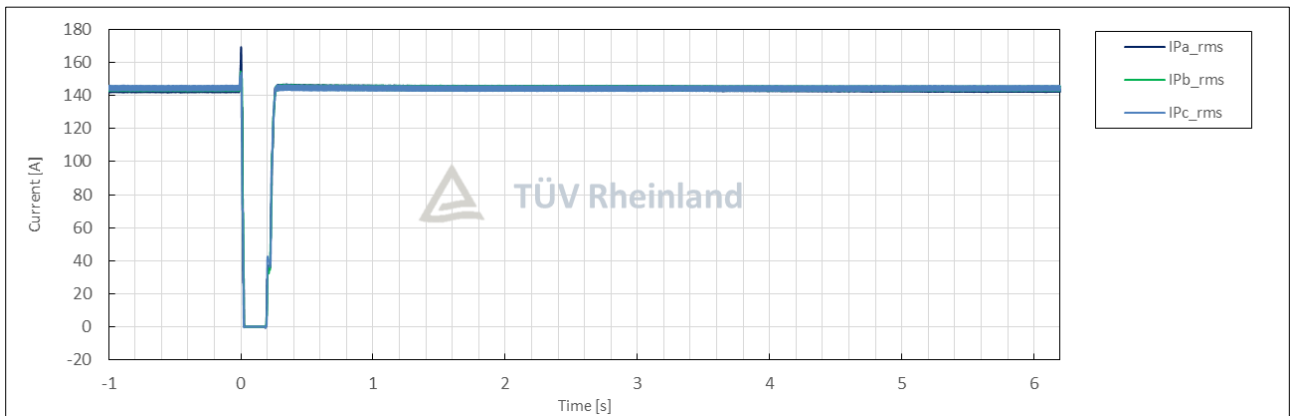
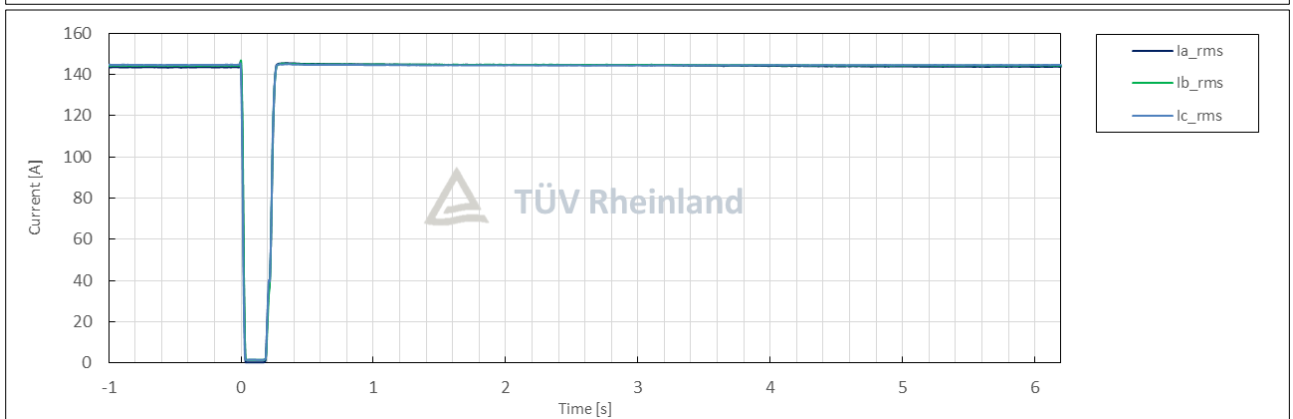
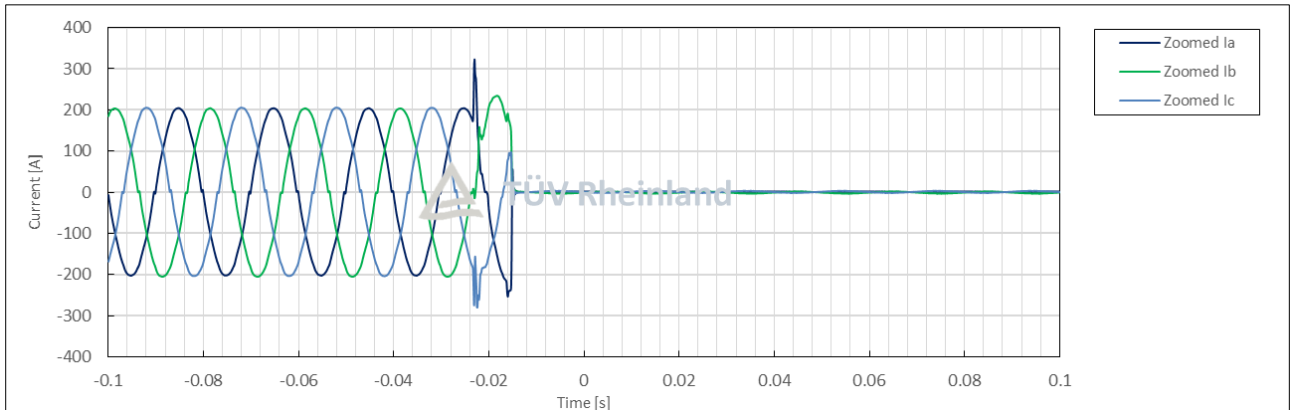

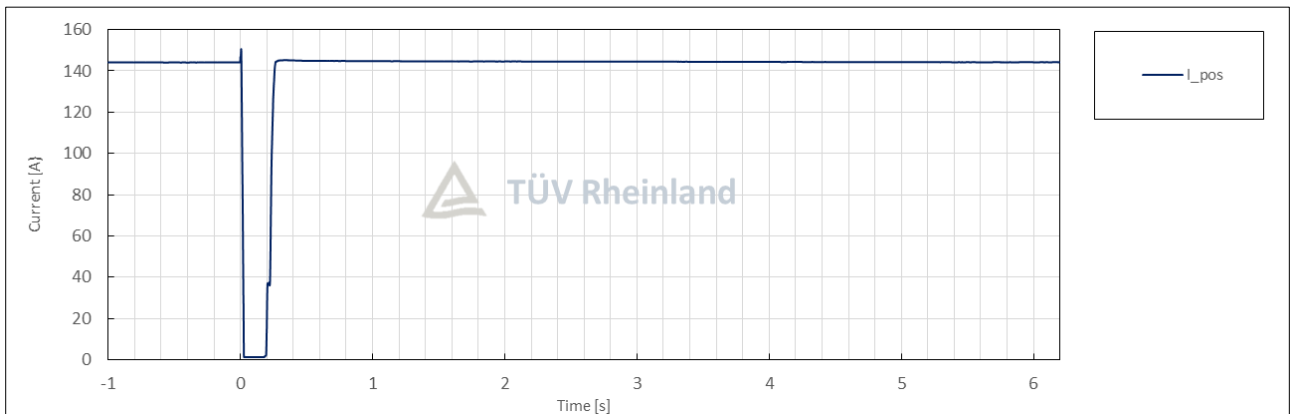
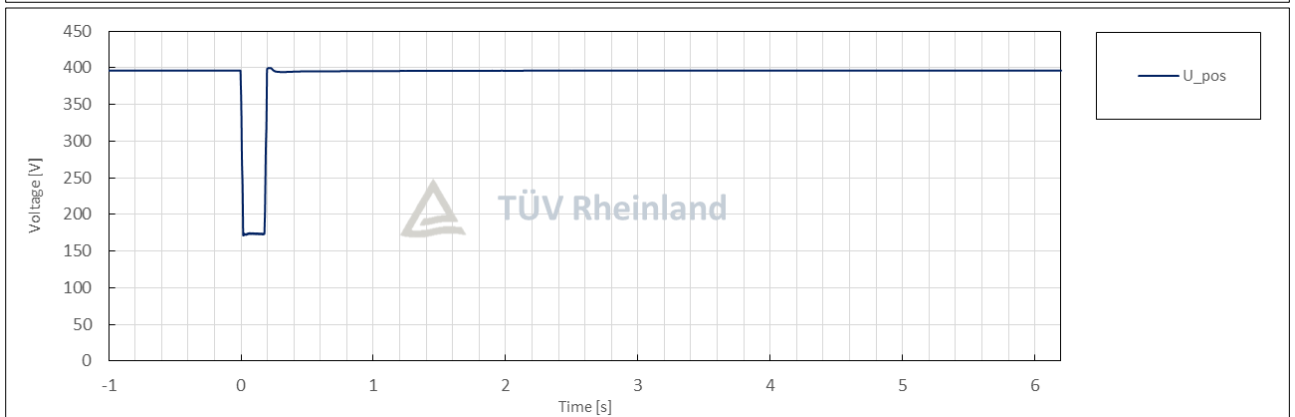
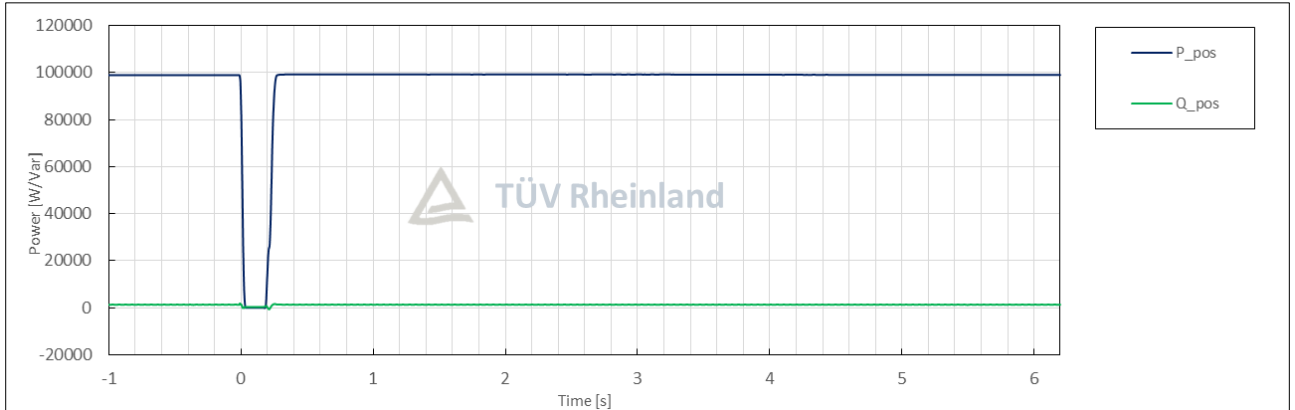

Condition						Measurement
No.	Parameter	Phase ref.	Time ref.	unit		
General Info.	0	Test number	--	--	--	1.4
	1	Date	--	--	dd.mm.yyyy	28.07.2025
	2	Time (start of test)	--	--	hh:mm:ss.f	13:49:47
	3	Fault type (phase)	--	--		2-phase fault
	4	Setting voltage depth	Line to line	--	p.u.	0.16
	5	Setting dip duration		--		196
	6	Point of fault entry	Total	--	ms	0
	7	Point of fault clearance	Total	--	ms	196
	8	Fault duration in empty load test	Total	--	ms	196
	9	Voltage depth/height in empty load test	Total	t1+100ms to t2 and t1-10s to t1	p.u.	0.16
10	Pos.		p.u.		0.43	
Before dip <t1	11	Voltage	Line to neutral	t1-100s to t1	p.u.	0.99
	12	Current	Pos.	t1-500ms to t1-100ms	p.u.	0.30
	13	Active power	Total	t1-10s to t1	p.u.	0.30
	14		Pos.			0.30
	15	Reactive power	Total	t1-10s to t1	p.u.	0.00
	16		Pos.			0.00
17	Cos ϕ	--	t1-10s to t1	--	1.000	
During dip t1 to t2	18	Voltage	Line to neutral	t1+100ms to t2-20ms	p.u.	0.15
	19	Line current	Phase 1	t1+60ms	p.u.	0.01
	20		Phase 2			0.00
	21		Phase 3			0.01
	22	Line current	Phase 1	t1+100ms	p.u.	0.01
	23		Phase 2			0.00
	24		Phase 3			0.01
	25	Active power	Total	t1+100ms to t2-20ms	p.u.	0.00
26	Pos.		0.00			
After dip > t2	27	Voltage	Line to neutral	t2+3s to t2+10s	p.u.	1.00
	28	Active power	Total	t2+3s to t2+10s	p.u.	0.30
	29		Pos.			0.30
	39	Active power rising time	Pos.	--	s	0.025
	31	Reactive power	Total	t2+3s to t2+10s	p.u.	0.00
	32		Pos.			0.00
	33	Reactive power rising time	Pos.	--	s	N/A
34	PGU does not disconnect from grid till 60s after fault	--	t2 to t2+60s	Yes / No	No	

Test No. 1.4 idle test

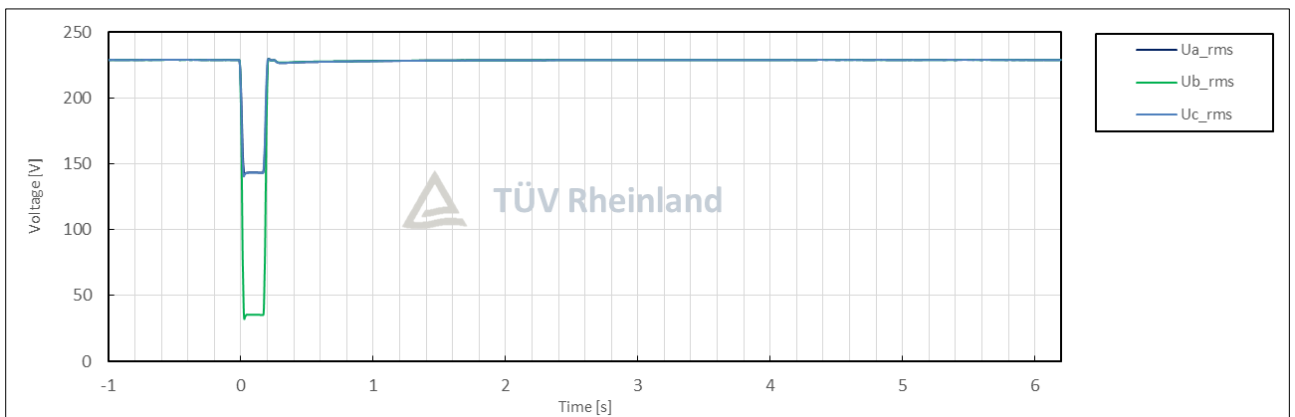
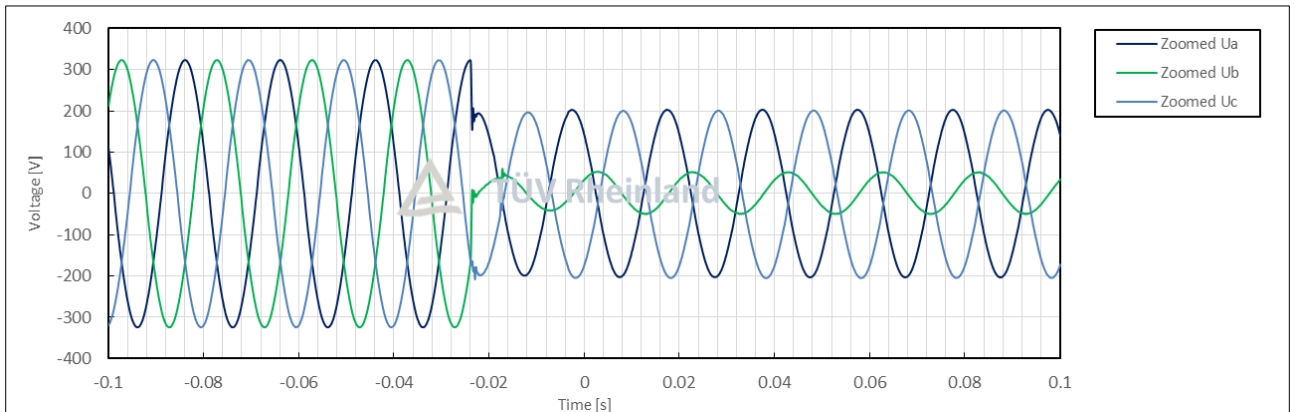
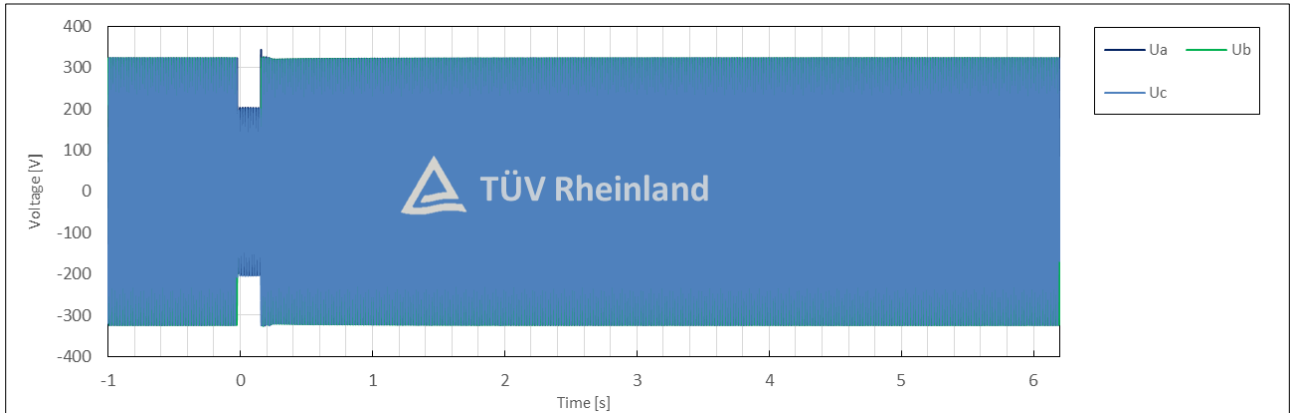

Test No. 1.4 with PGU

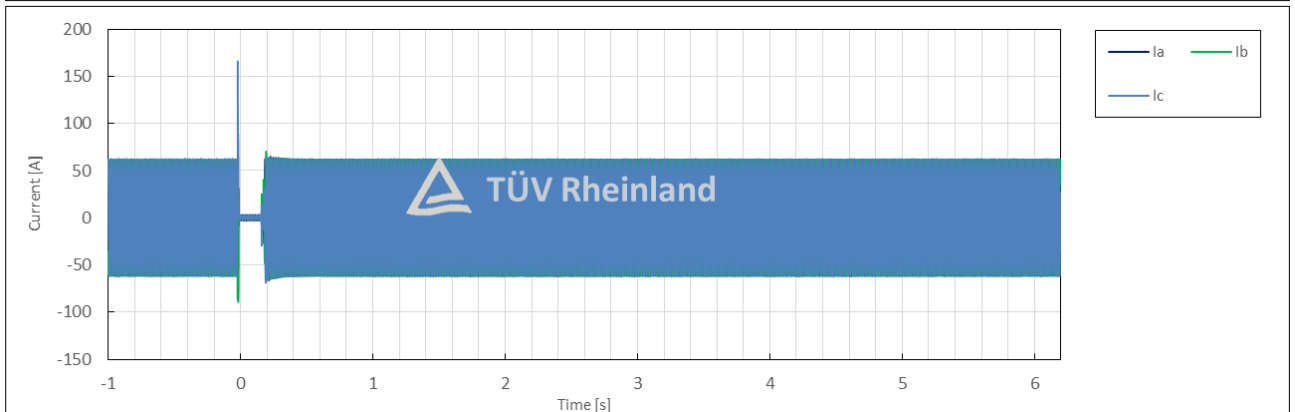
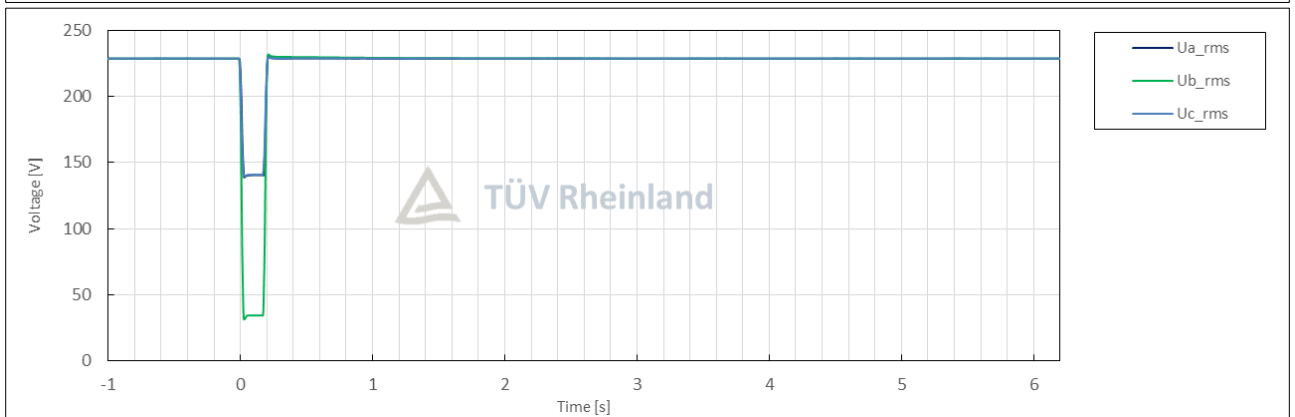
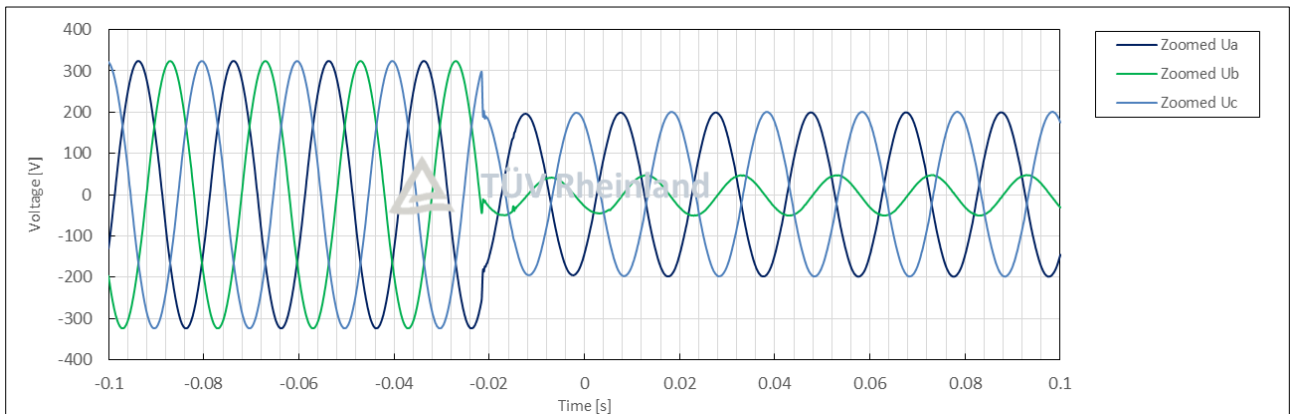
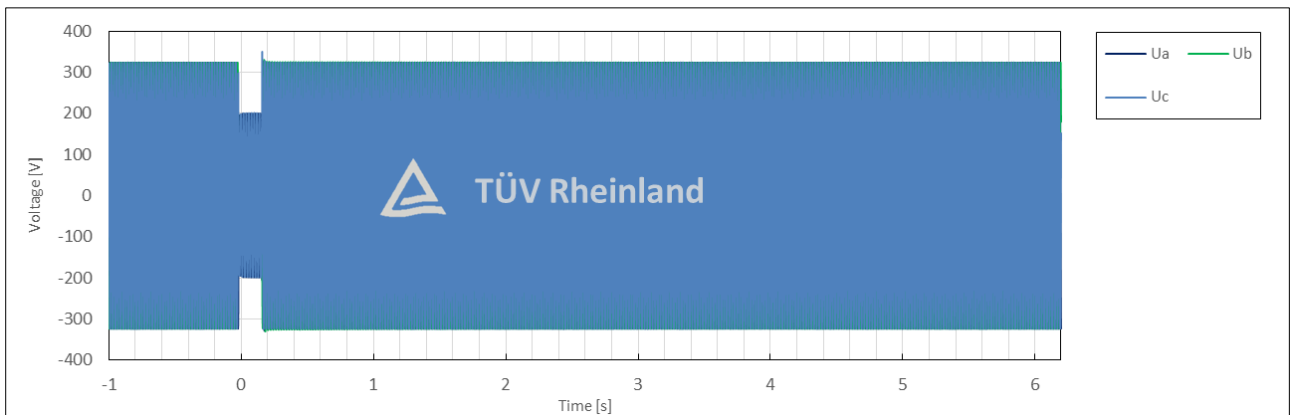

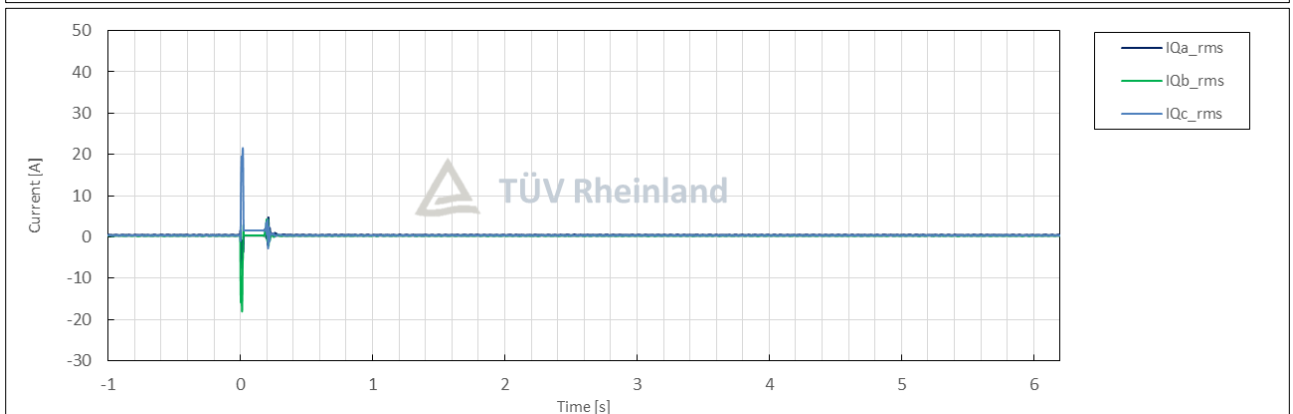
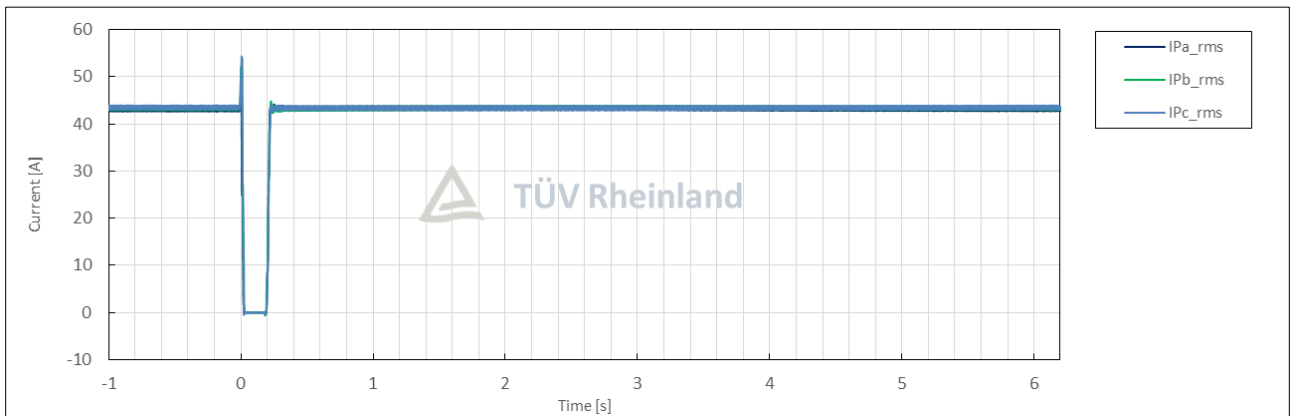
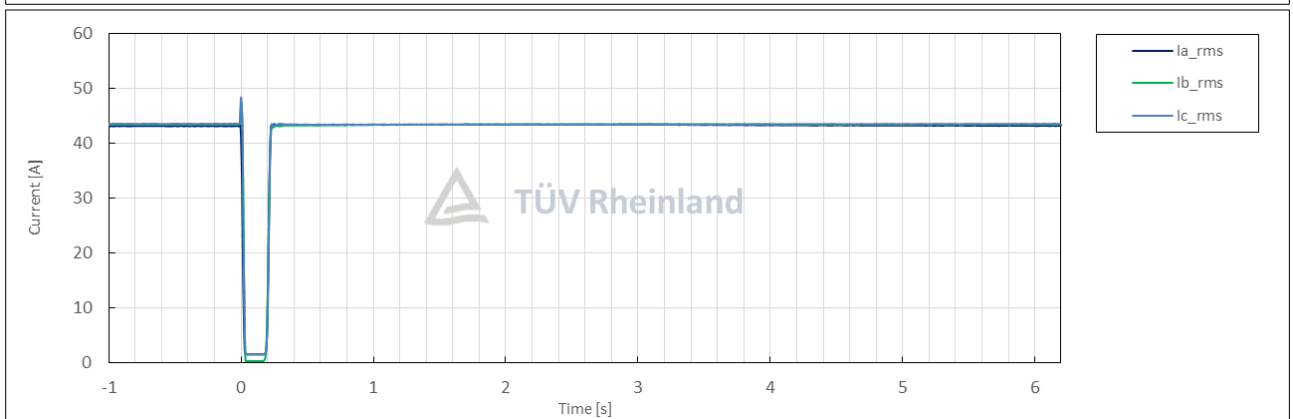
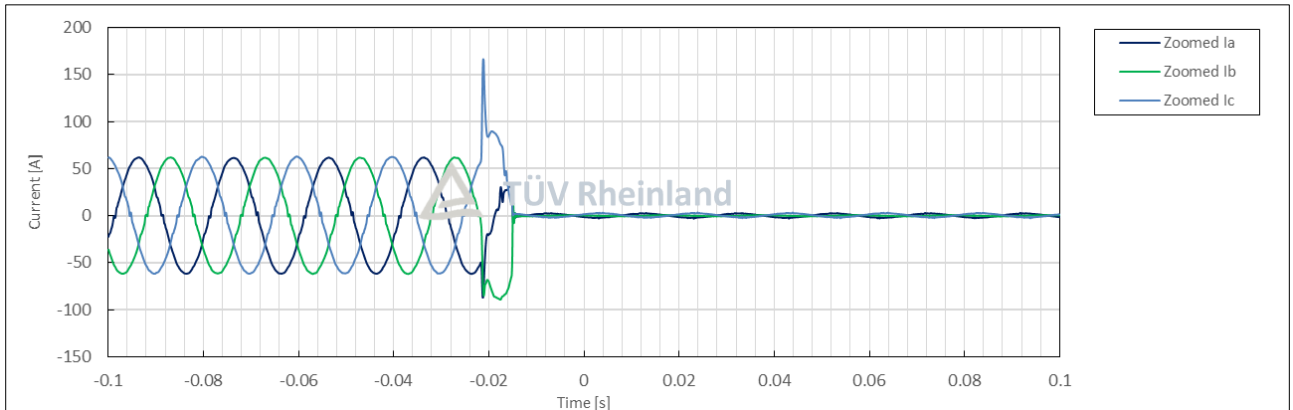

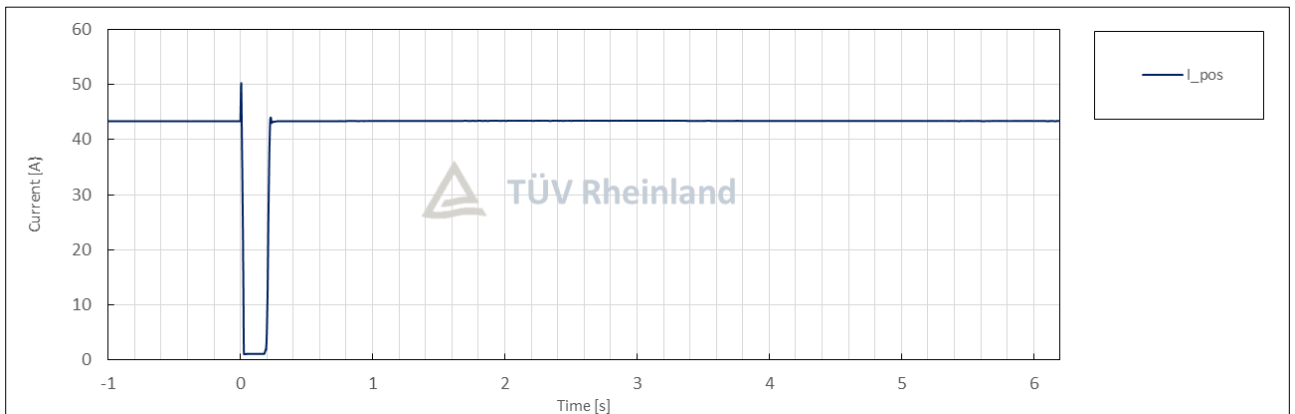
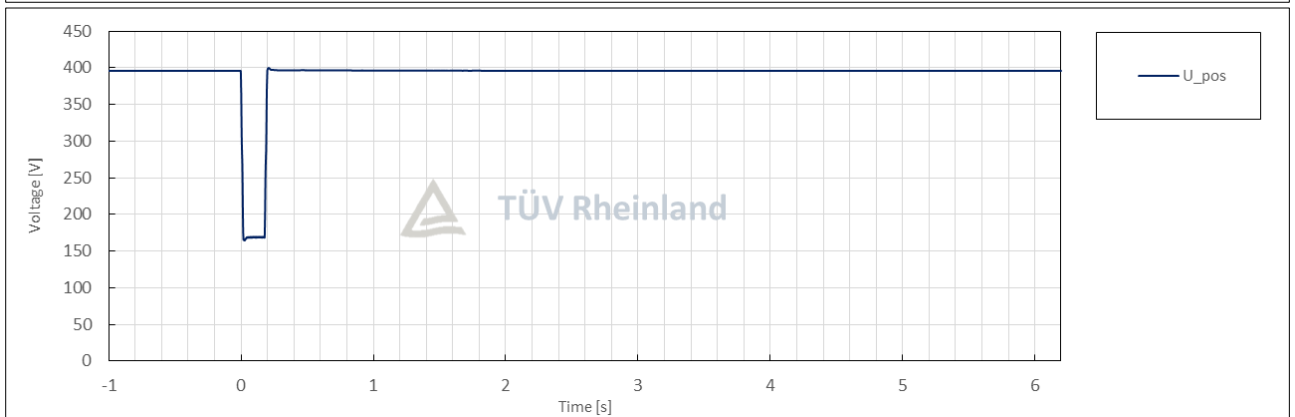
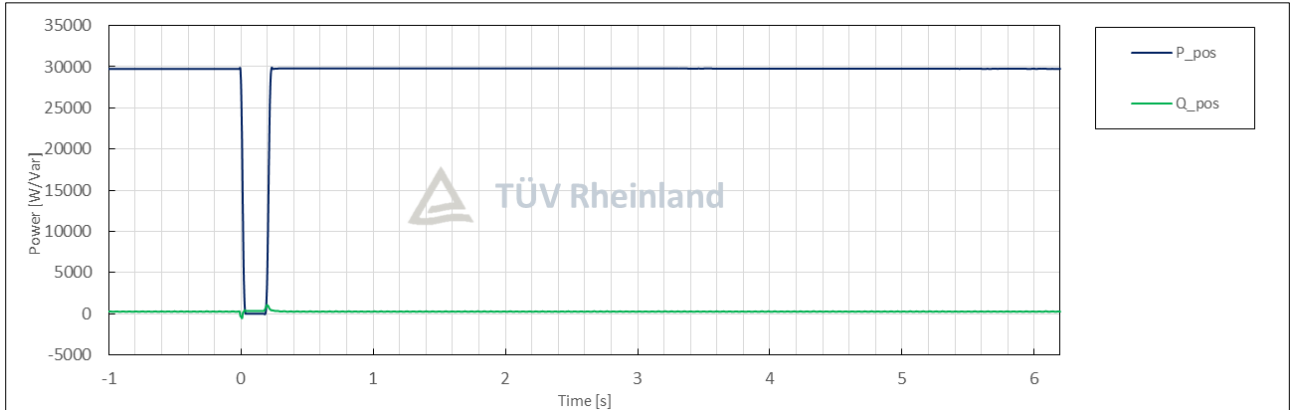

Condition						Measurement
No.	Parameter	Phase ref.	Time ref.	unit		
General Info.	0	Test number	--	--	--	2.1
	1	Date	--	--	dd.mm.yyyy	28.07.2025
	2	Time (start of test)	--	--	hh:mm:ss.f	13:49:47
	3	Fault type (phase)	--	--		3-phase fault
	4	Setting voltage depth	Line to line	--	p.u.	0.50
	5	Setting dip duration		--		1544
	6	Point of fault entry	Total	--	ms	0
	7	Point of fault clearance	Total	--	ms	1544
	8	Fault duration in empty load test	Total	--	ms	1544
	9	Voltage depth/height in empty load test	Total	t1+100ms to t2 and t1-10s to t1	p.u.	0.50
10	Pos.		p.u.		0.50	
Before dip <t1	11	Voltage	Line to neutral	t1-100s to t1	p.u.	1.00
	12	Current	Pos.	t1-500ms to t1-100ms	p.u.	1.08
	13	Active power	Total	t1-10s to t1	p.u.	0.98
	14		Pos.			0.98
	15	Reactive power	Total	t1-10s to t1	p.u.	0.43
	16		Pos.			0.43
17	Cos ϕ	--	t1-10s to t1	--	0.914	
During dip t1 to t2	18	Voltage	Line to neutral	t1+100ms to t2-20ms	p.u.	0.50
	19	Line current	Phase 1	t1+60ms	p.u.	0.01
	20		Phase 2			0.01
	21		Phase 3			0.01
	22	Line current	Phase 1	t1+100ms	p.u.	0.01
	23		Phase 2			0.01
	24		Phase 3			0.01
	25	Active power	Total	t1+100ms to t2-20ms	p.u.	0.00
26	Pos.		0.00			
After dip > t2	27	Voltage	Line to neutral	t2+3s to t2+10s	p.u.	1.00
	28	Active power	Total	t2+3s to t2+10s	p.u.	0.98
	29		Pos.			0.98
	39	Active power rising time	Pos.	--	s	0.045
	31	Reactive power	Total	t2+3s to t2+10s	p.u.	0.36
	32		Pos.			0.36
	33	Reactive power rising time	Pos.	--	s	9.807
34	PGU does not disconnect from grid till 60s after fault	--	t2 to t2+60s	Yes / No	No	

Test No. 2.1 idle test

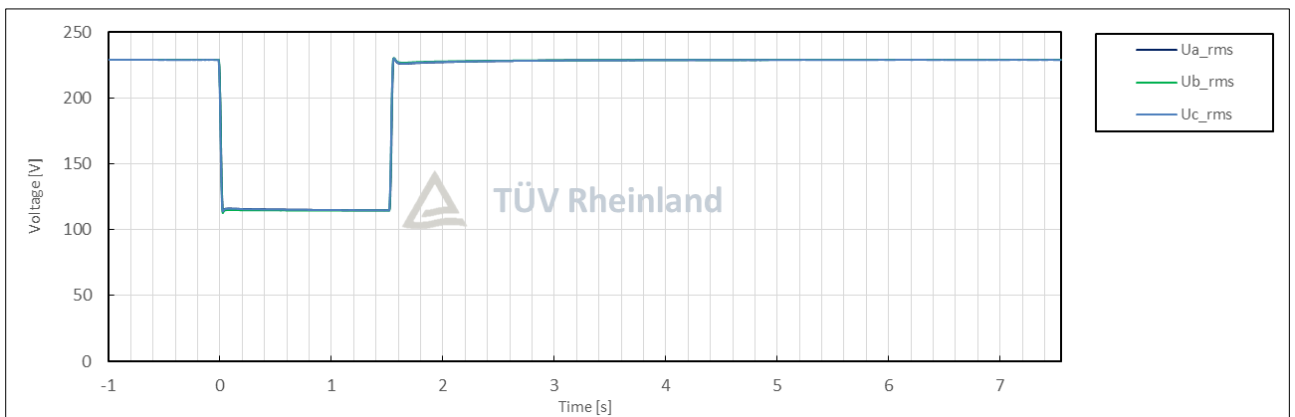
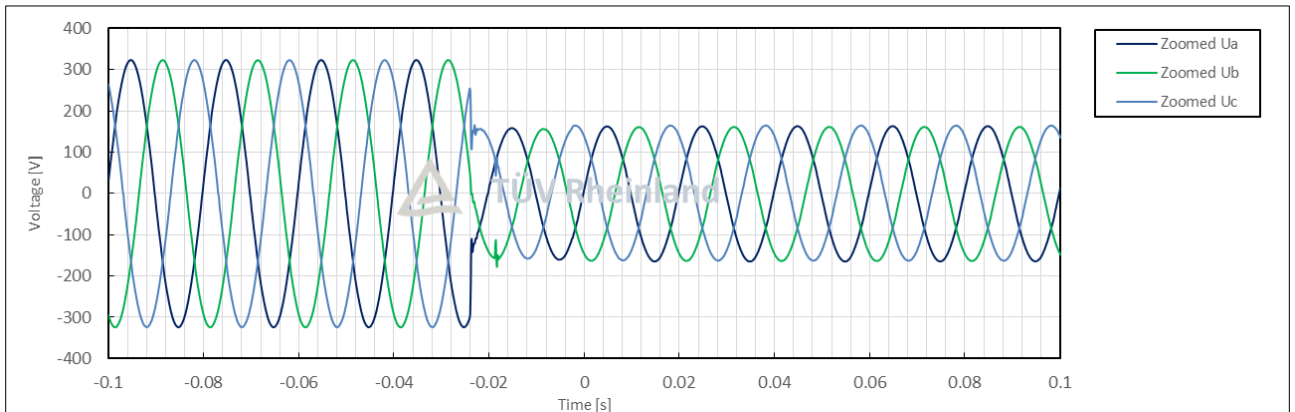
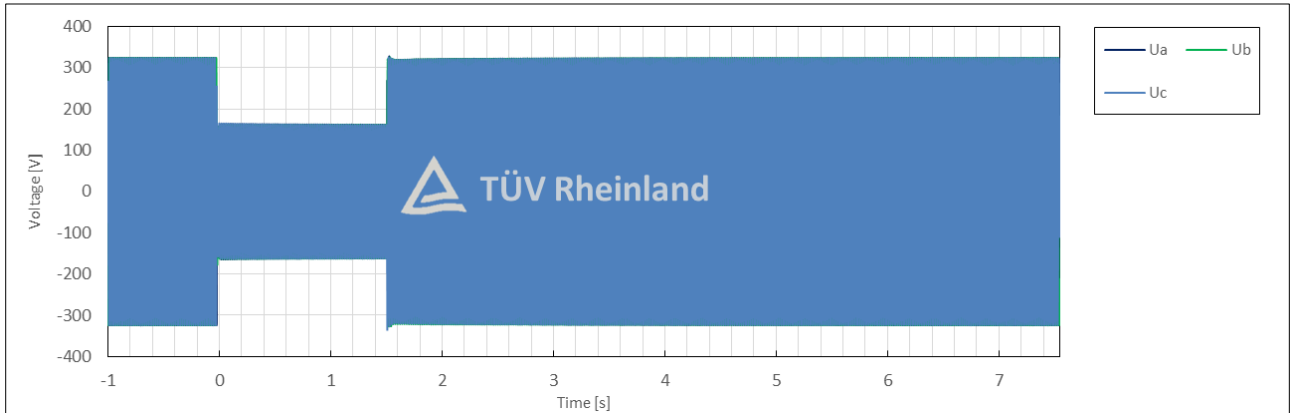

Test No. 2.1 with PGU

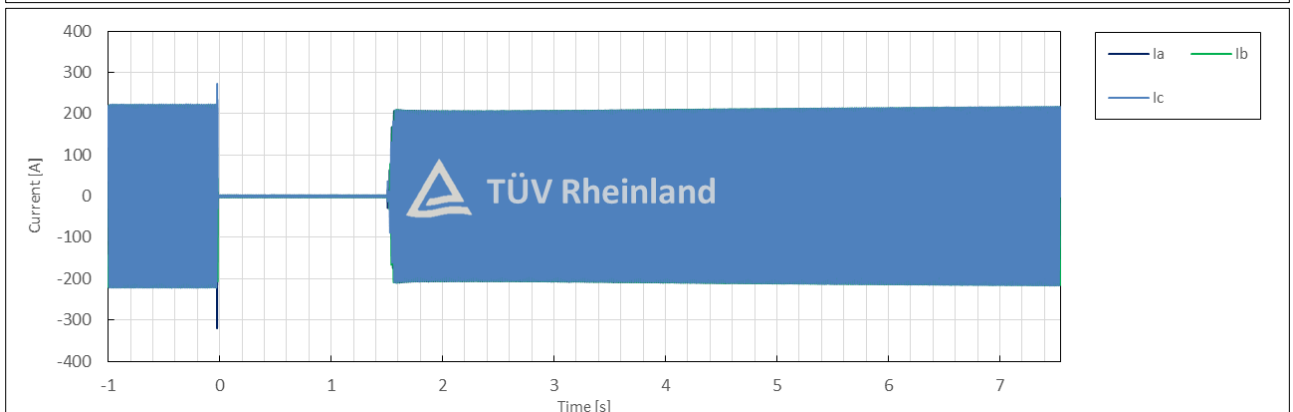
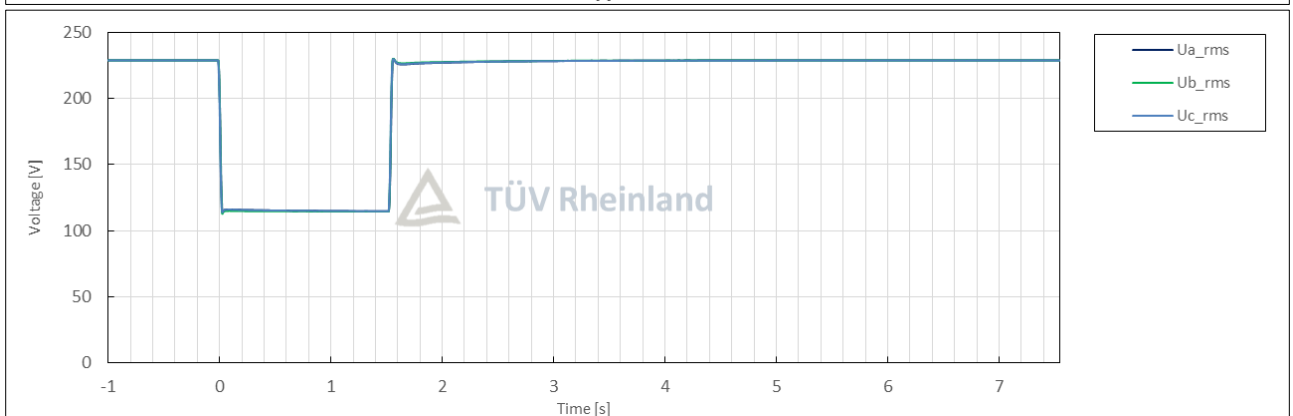
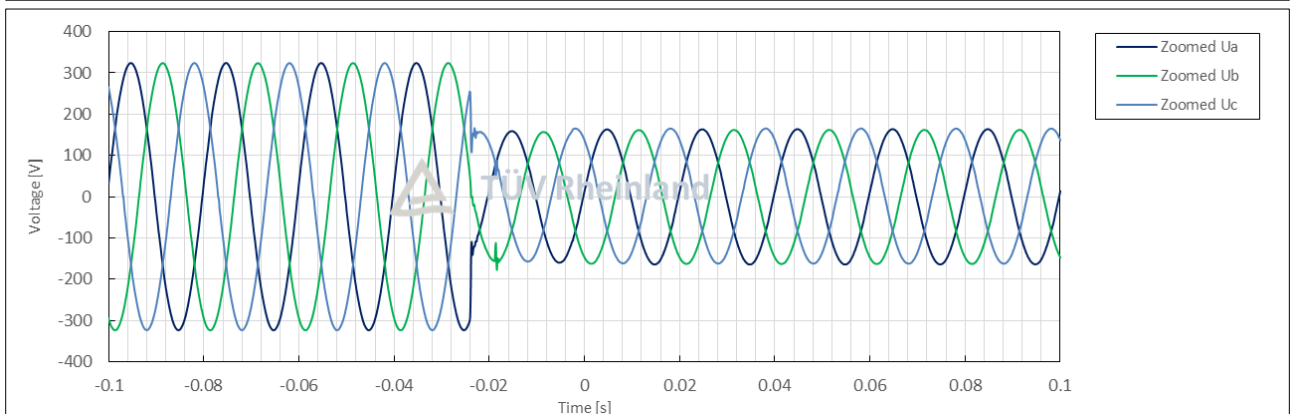
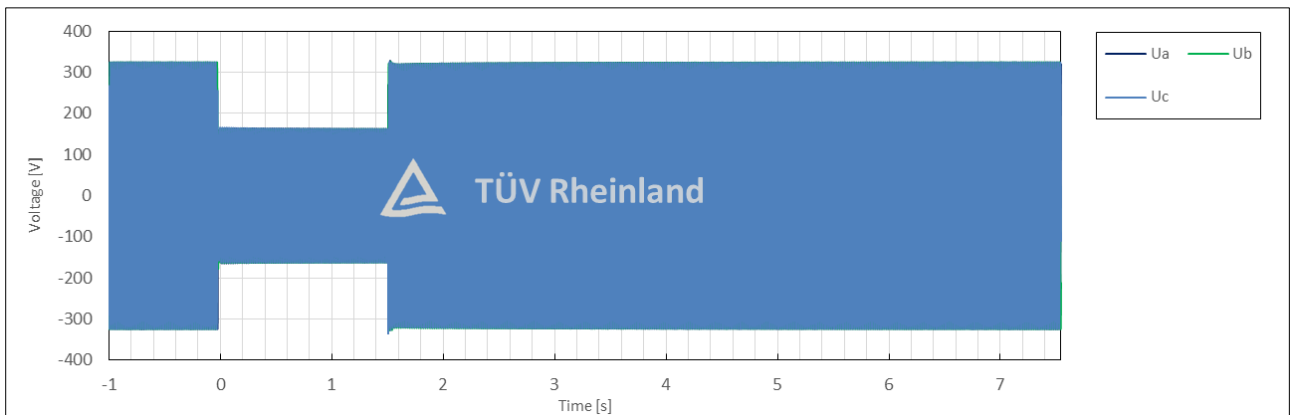

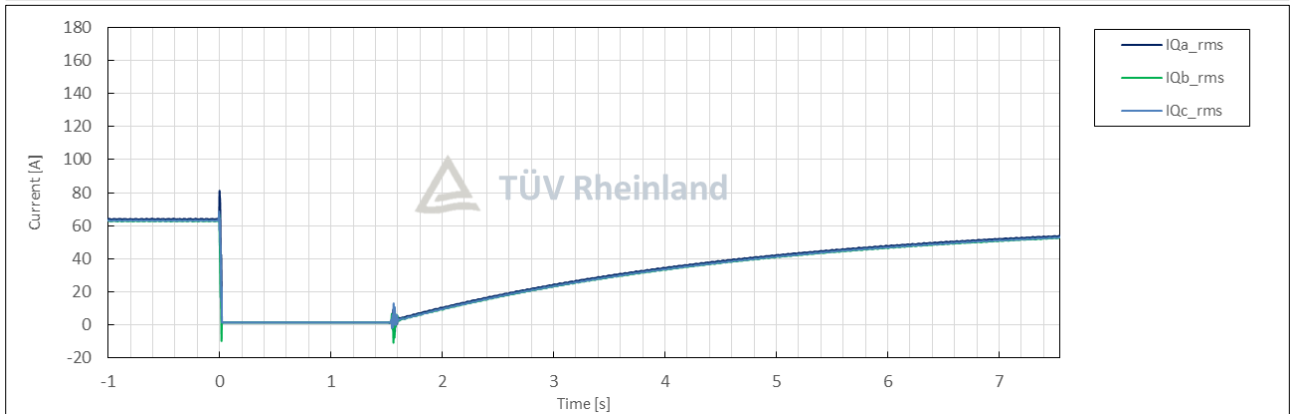
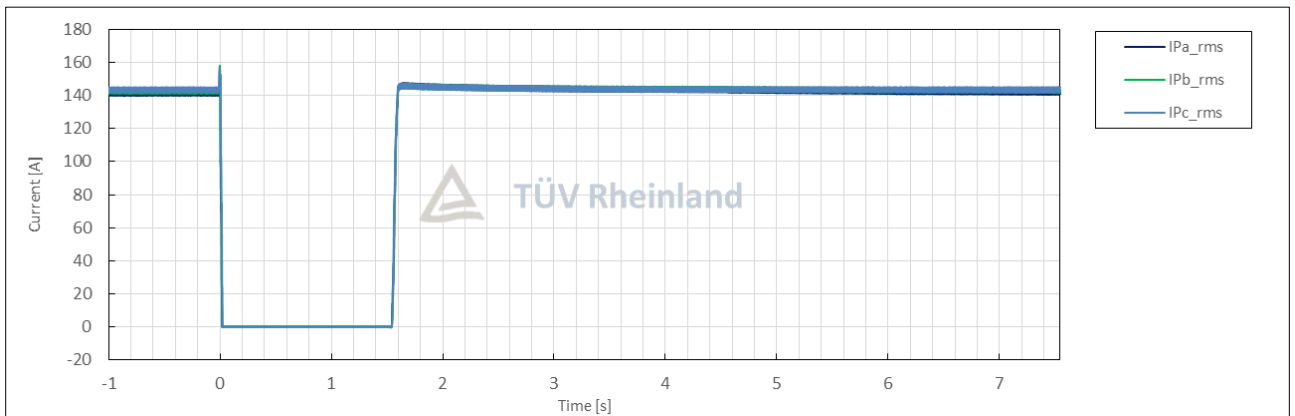
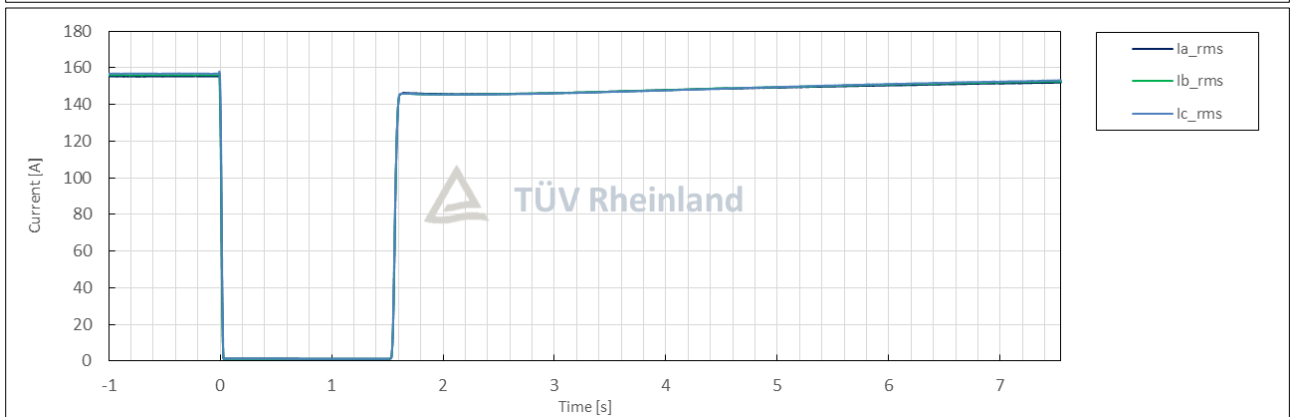
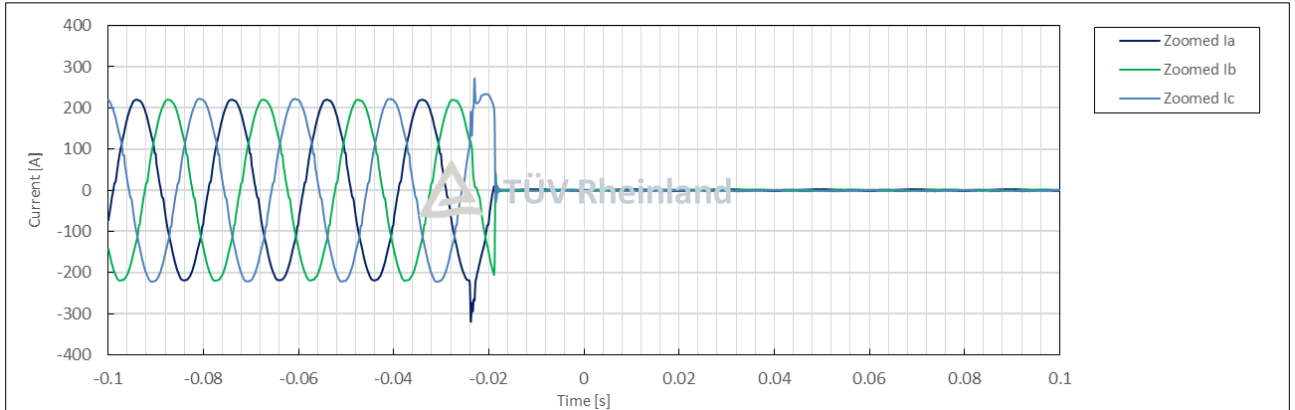

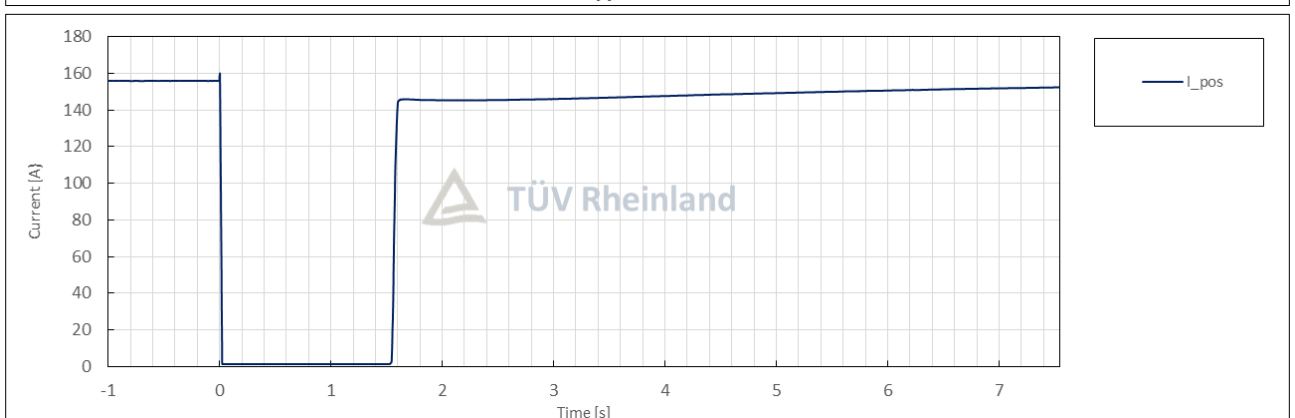
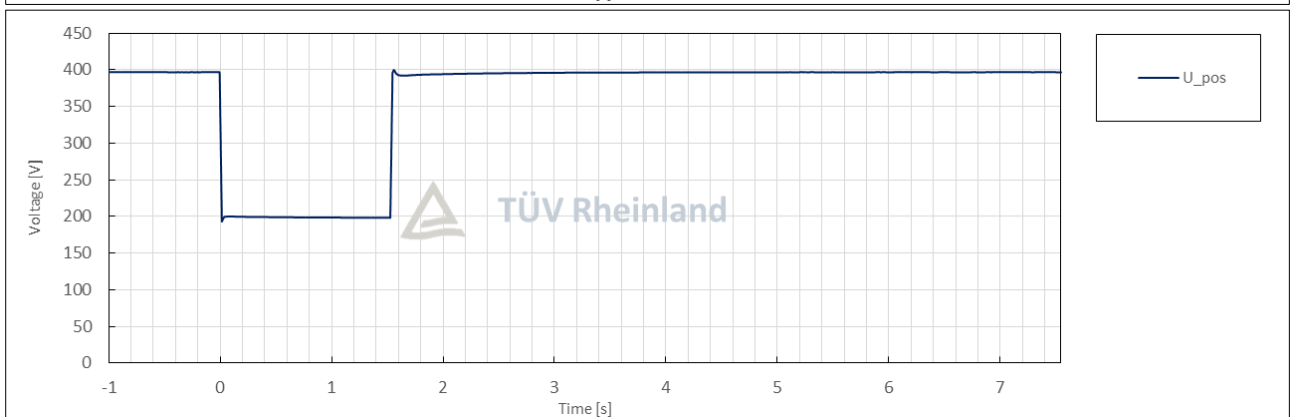
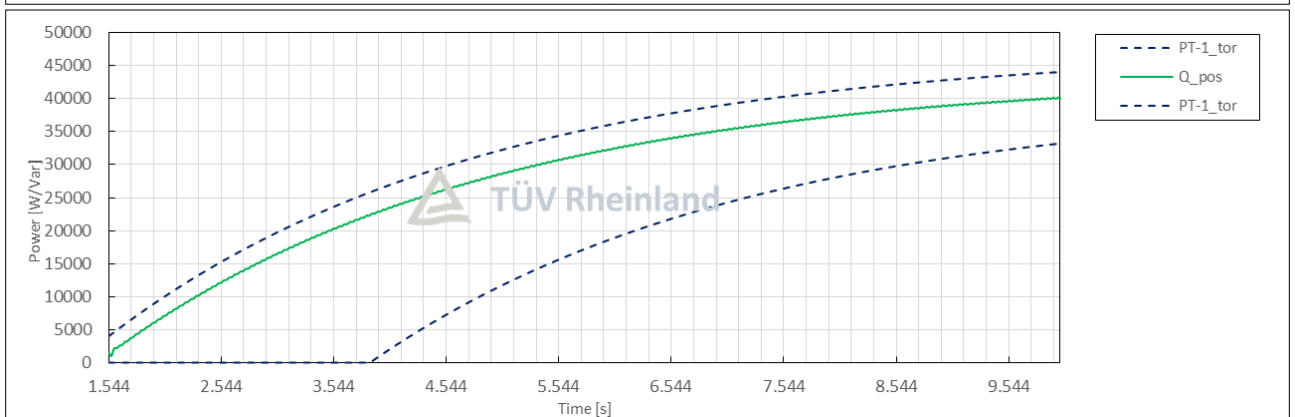
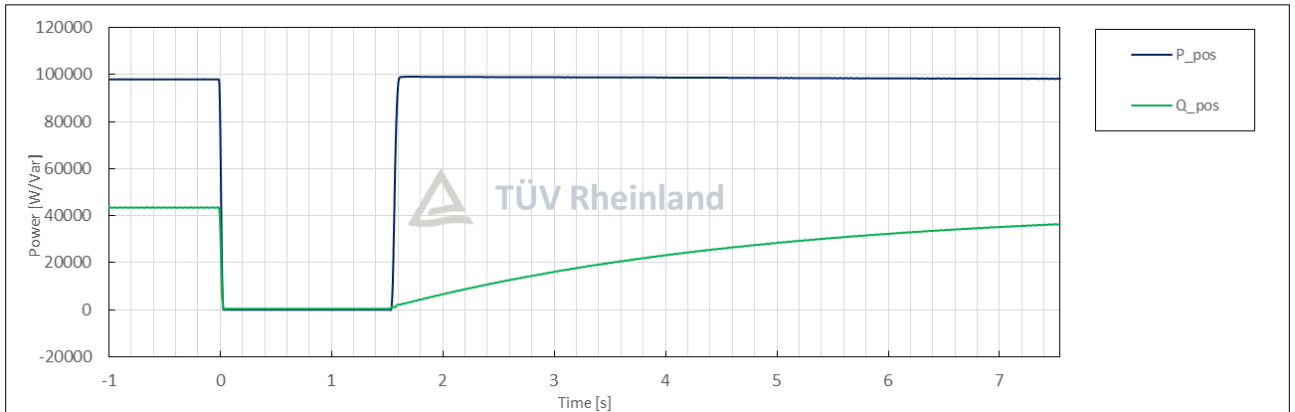

Prüfbericht-Nr.: CN25J408 002 Attachment 1
Test report no.:

Seite 62 von 181
 Page 62 of 181

Condition						Measurement
No.	Parameter	Phase ref.	Time ref.	unit		
General Info.	0	Test number	--	--	--	2.2
	1	Date	--	--	dd.mm.yyyy	28.07.2025
	2	Time (start of test)	--	--	hh:mm:ss.f	13:50:03
	3	Fault type (phase)	--	--		3-phase fault
	4	Setting voltage depth	Line to line	--	p.u.	0.50
	5	Setting dip duration		--		1544
	6	Point of fault entry	Total	--	ms	0
	7	Point of fault clearance	Total	--	ms	1544
	8	Fault duration in empty load test	Total	--	ms	1544
	9	Voltage depth/height in empty load test	Total	t1+100ms to t2 and t1-10s to t1	p.u.	0.50
	10		Pos.		p.u.	0.50
Before dip <t1	11	Voltage	Line to neutral	t1-100s to t1	p.u.	1.00
	12	Current	Pos.	t1-500ms to t1-100ms	p.u.	0.52
	13	Active power	Total	t1-10s to t1	p.u.	0.29
	14		Pos.			0.29
	15	Reactive power	Total	t1-10s to t1	p.u.	0.42
	16		Pos.			0.42
	17	Cos ϕ	--	t1-10s to t1	--	0.563
During dip t1 to t2	18	Voltage	Line to neutral	t1+100ms to t2-20ms	p.u.	0.50
	19	Line current	Phase 1	t1+60ms	p.u.	0.01
	20		Phase 2			0.01
	21		Phase 3			0.01
	22	Line current	Phase 1	t1+100ms	p.u.	0.01
	23		Phase 2			0.01
	24		Phase 3			0.01
	25	Active power	Total	t1+100ms to t2-20ms	p.u.	0.00
26	Pos.		0.00			
After dip > t2	27	Voltage	Line to neutral	t2+3s to t2+10s	p.u.	0.99
	28	Active power	Total	t2+3s to t2+10s	p.u.	0.29
	29		Pos.			0.29
	39	Active power rising time	Pos.	--	s	0.026
	31	Reactive power	Total	t2+3s to t2+10s	p.u.	0.35
	32		Pos.			0.35
	33	Reactive power rising time	Pos.	--	s	9.959
	34	PGU does not disconnect from grid till 60s after fault	--	t2 to t2+60s	Yes / No	No

Test No. 2.2 idle test

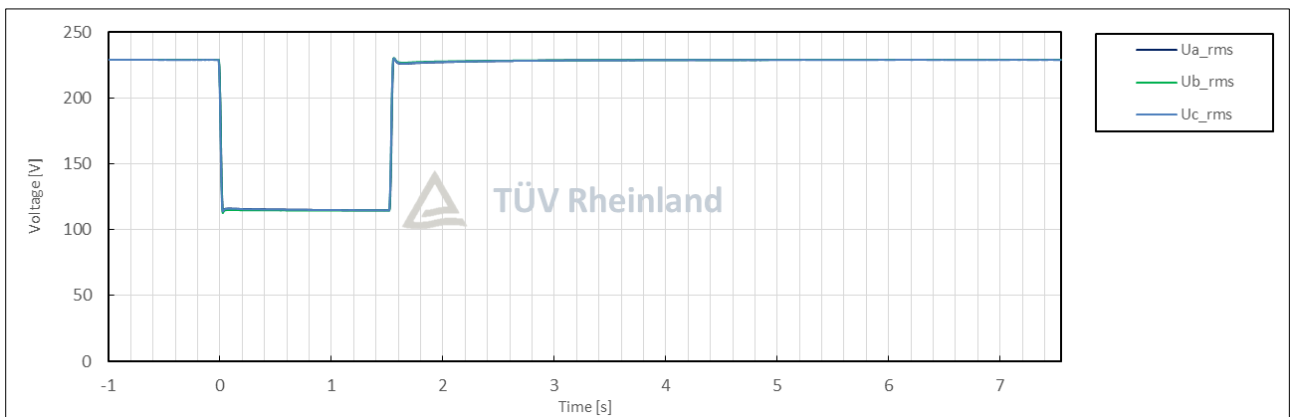
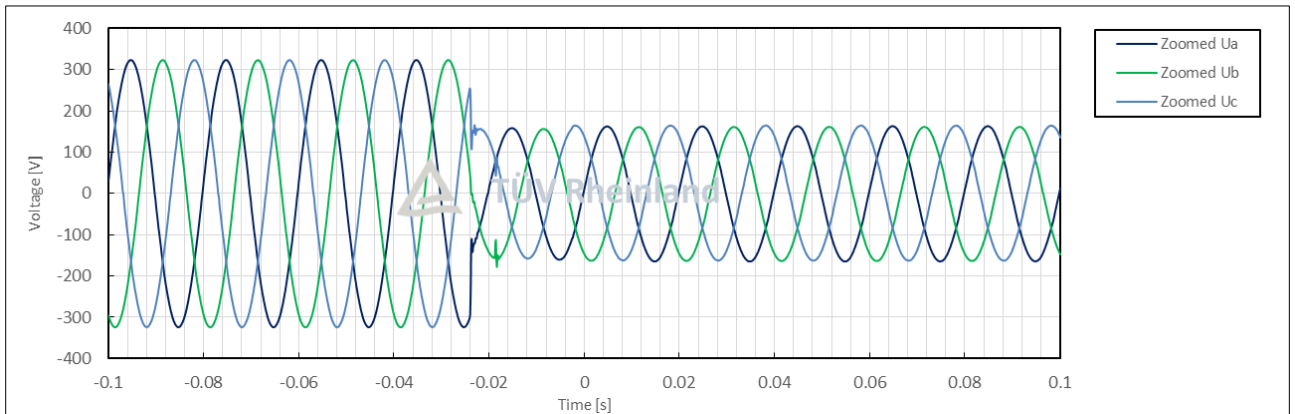
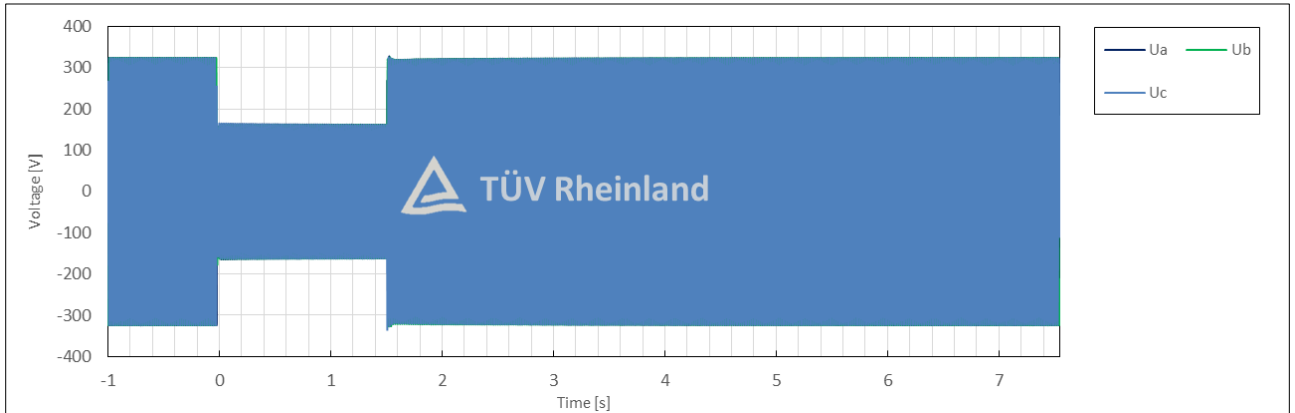

Test No. 2.2 with PGU

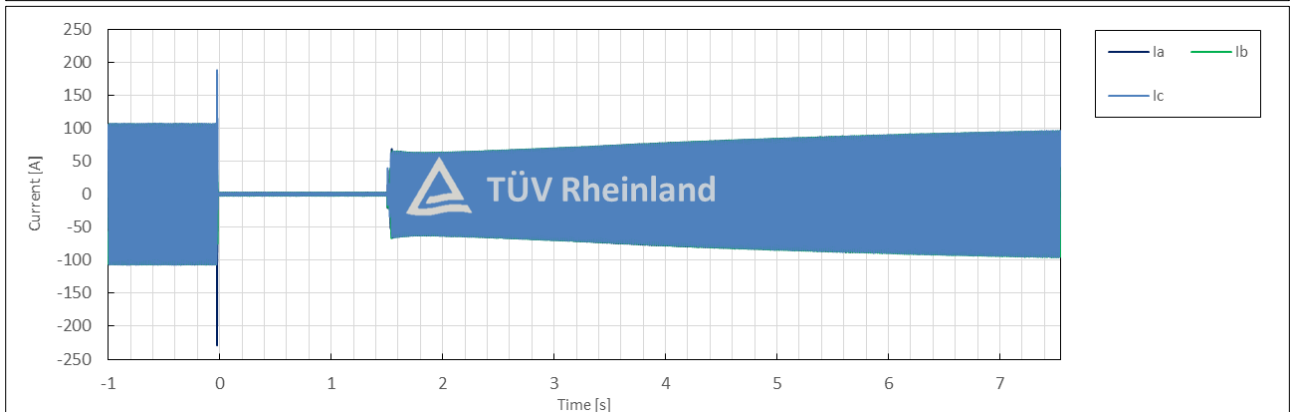
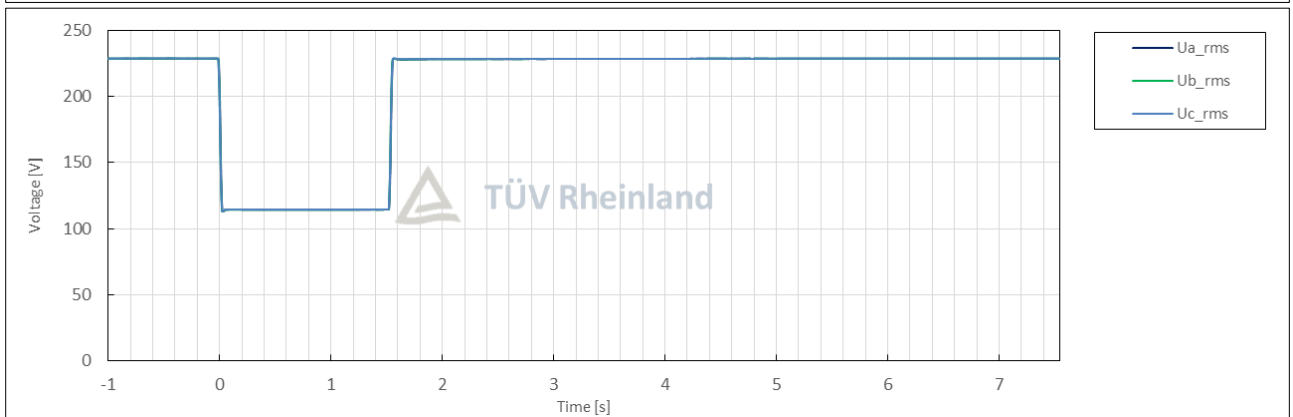
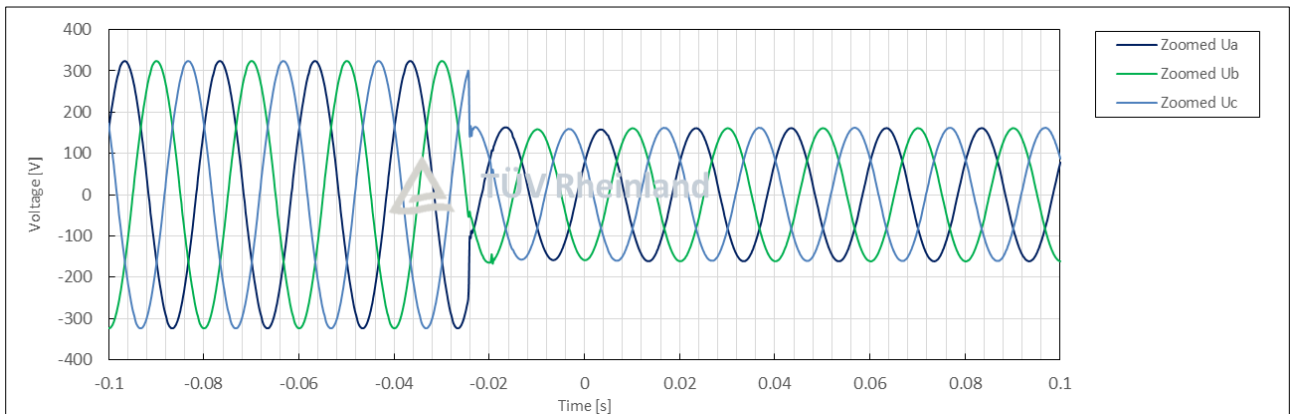
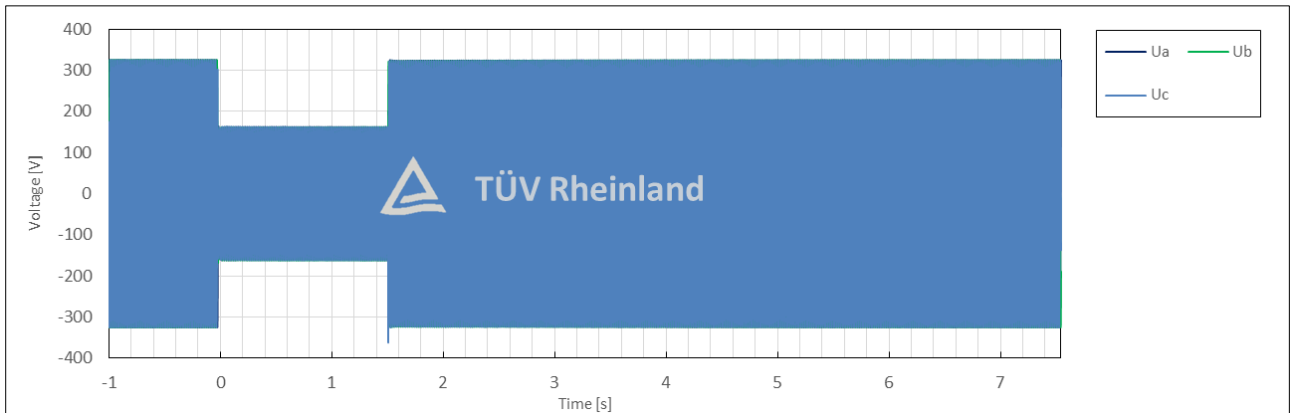

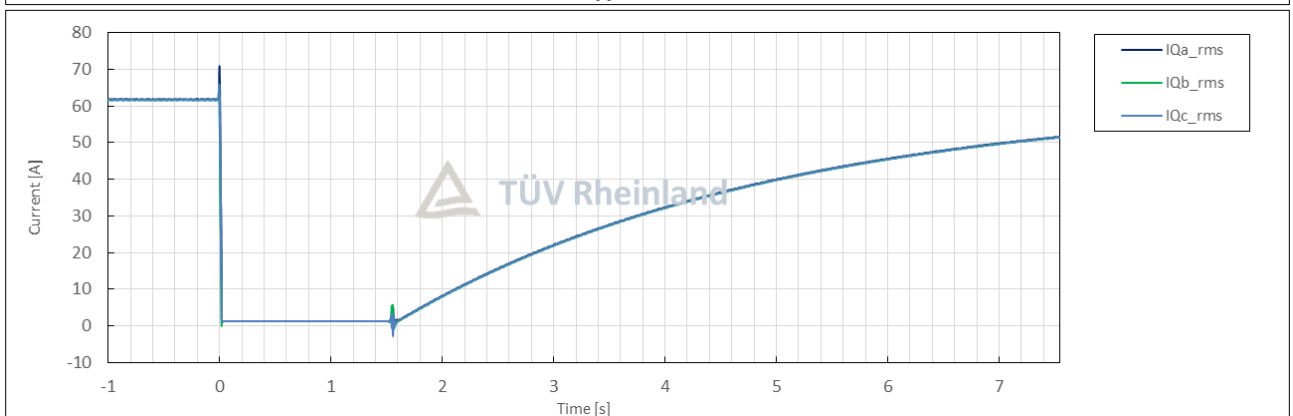
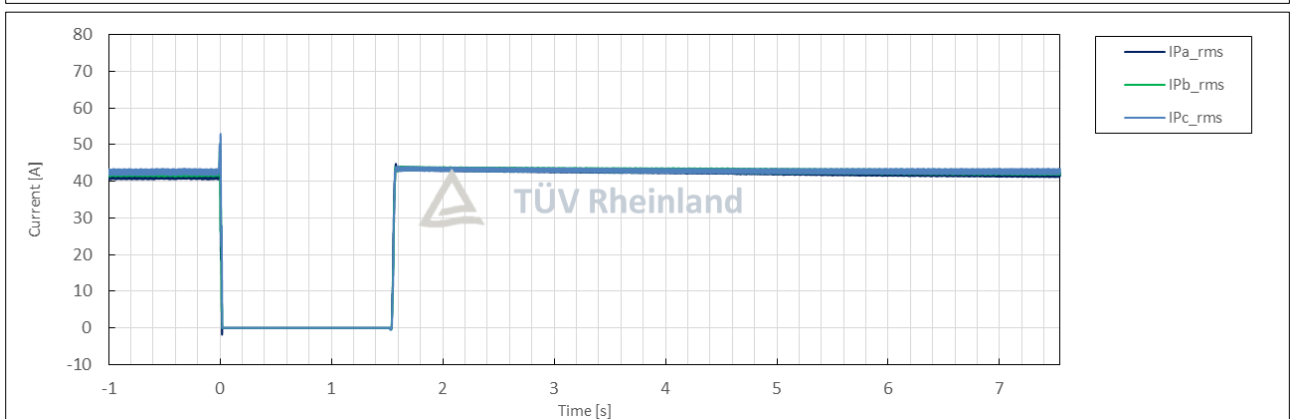
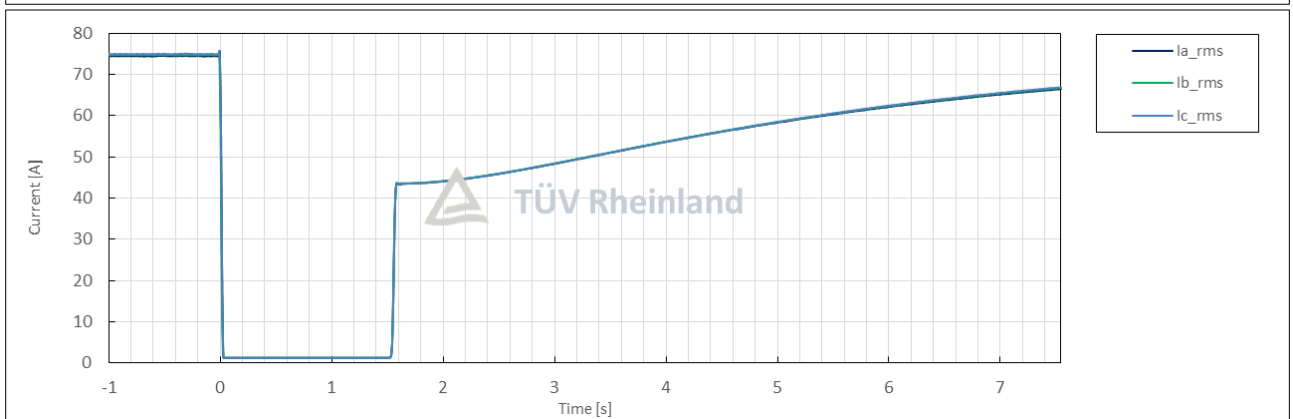
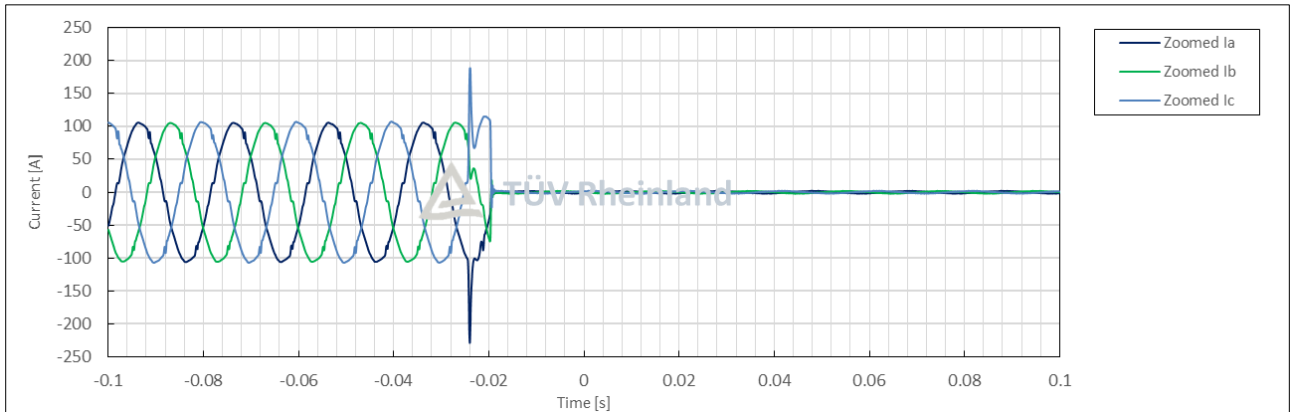

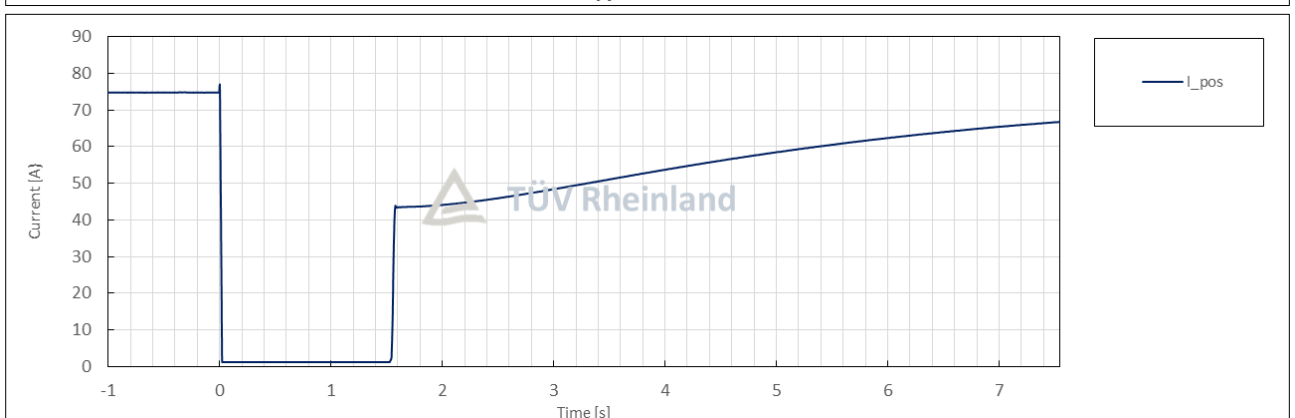
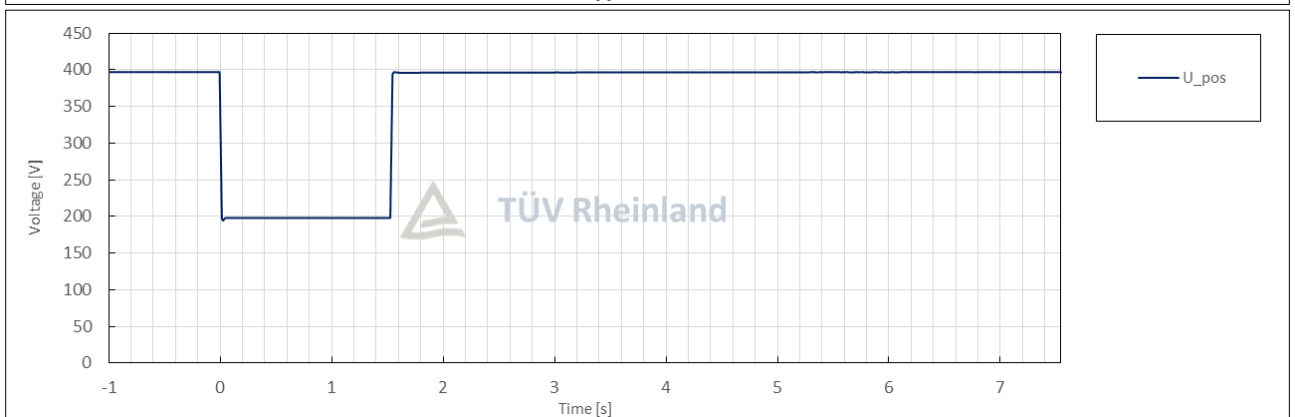
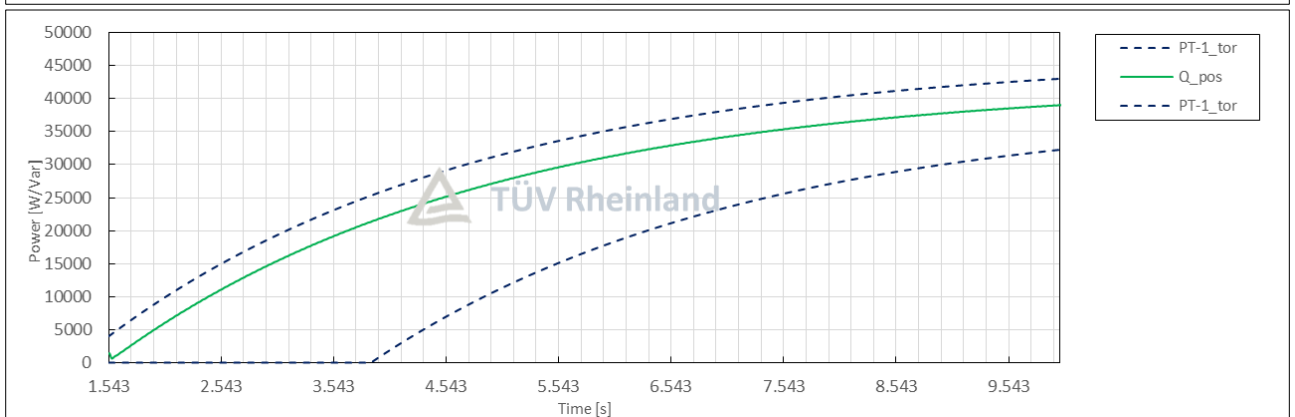
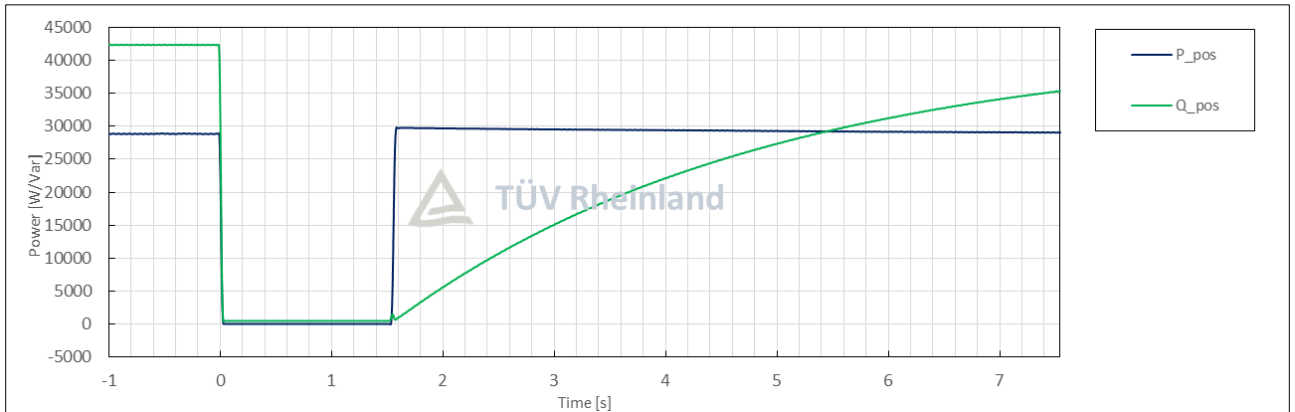

Prüfbericht-Nr.: CN25J408 002 Attachment 1
Test report no.:

Seite 67 von 181
 Page 67 of 181

Condition						Measurement
No.	Parameter	Phase ref.	Time ref.	unit		
General Info.	0	Test number	--	--	--	2.3
	1	Date	--	--	dd.mm.yyyy	28.07.2025
	2	Time (start of test)	--	--	hh:mm:ss.f	13:50:13
	3	Fault type (phase)	--	--		2-phase fault
	4	Setting voltage depth	Line to line	--	p.u.	0.50
	5	Setting dip duration		--		1561
	6	Point of fault entry	Total	--	ms	0
	7	Point of fault clearance	Total	--	ms	1561
	8	Fault duration in empty load test	Total	--	ms	1561
	9	Voltage depth/height in empty load test	Total	t1+100ms to t2 and t1-10s to t1	p.u.	0.50
	10		Pos.		p.u.	0.67
Before dip <t1	11	Voltage	Line to neutral	t1-100s to t1	p.u.	1.00
	12	Current	Pos.	t1-500ms to t1-100ms	p.u.	1.08
	13	Active power	Total	t1-10s to t1	p.u.	0.98
	14		Pos.			0.98
	15	Reactive power	Total	t1-10s to t1	p.u.	0.43
	16		Pos.			0.43
	17	Cos ϕ	--	t1-10s to t1	--	0.914
During dip t1 to t2	18	Voltage	Line to neutral	t1+100ms to t2-20ms	p.u.	0.50
	19	Line current	Phase 1	t1+60ms	p.u.	0.01
	20		Phase 2			0.01
	21		Phase 3			0.01
	22	Line current	Phase 1	t1+100ms	p.u.	0.01
	23		Phase 2			0.01
	24		Phase 3			0.01
	25	Active power	Total	t1+100ms to t2-20ms	p.u.	0.00
26	Pos.		0.00			
After dip > t2	27	Voltage	Line to neutral	t2+3s to t2+10s	p.u.	1.00
	28	Active power	Total	t2+3s to t2+10s	p.u.	0.98
	29		Pos.			0.98
	39	Active power rising time	Pos.	--	s	0.056
	31	Reactive power	Total	t2+3s to t2+10s	p.u.	0.36
	32		Pos.			0.36
	33	Reactive power rising time	Pos.	--	s	9.792
	34	PGU does not disconnect from grid till 60s after fault	--	t2 to t2+60s	Yes / No	No

Test No. 2.3 idle test

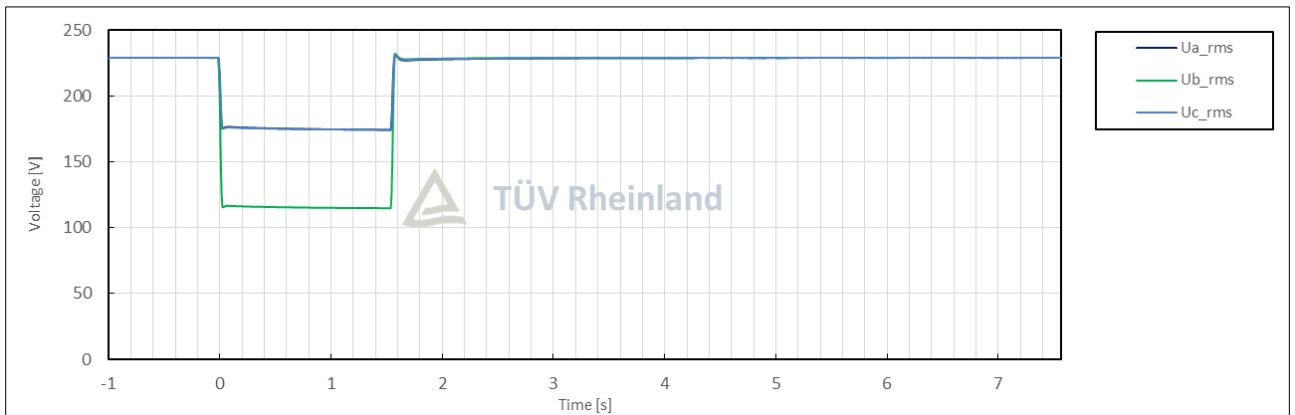
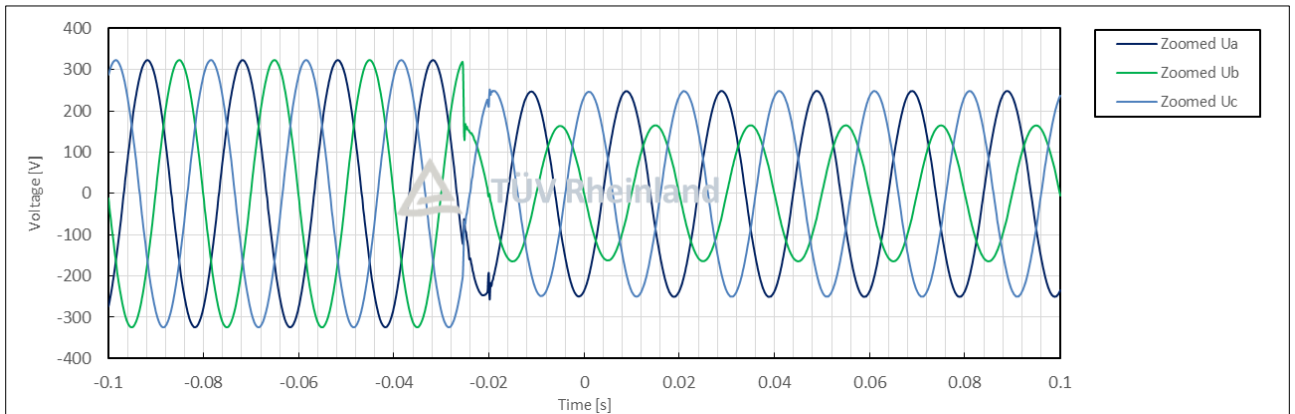
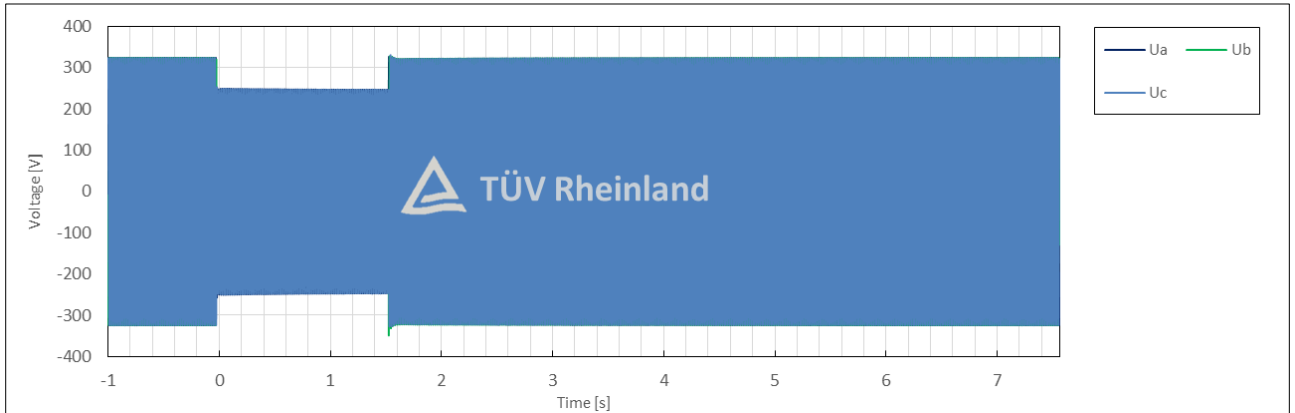

Test No. 2.3 with PGU

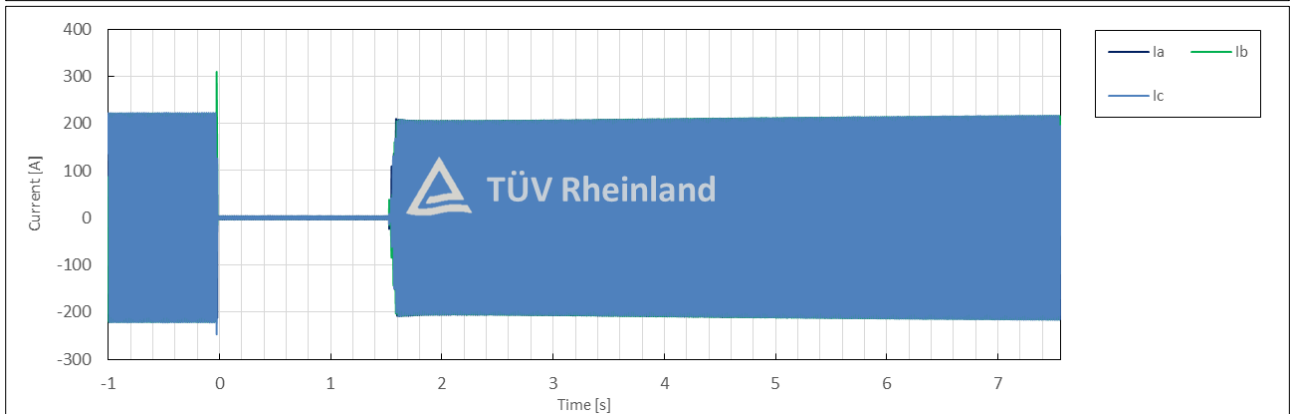
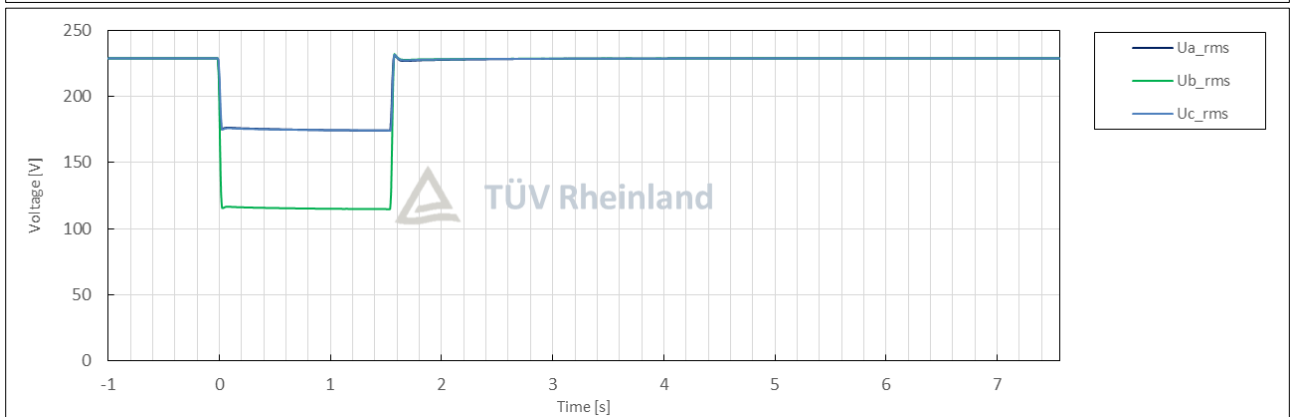
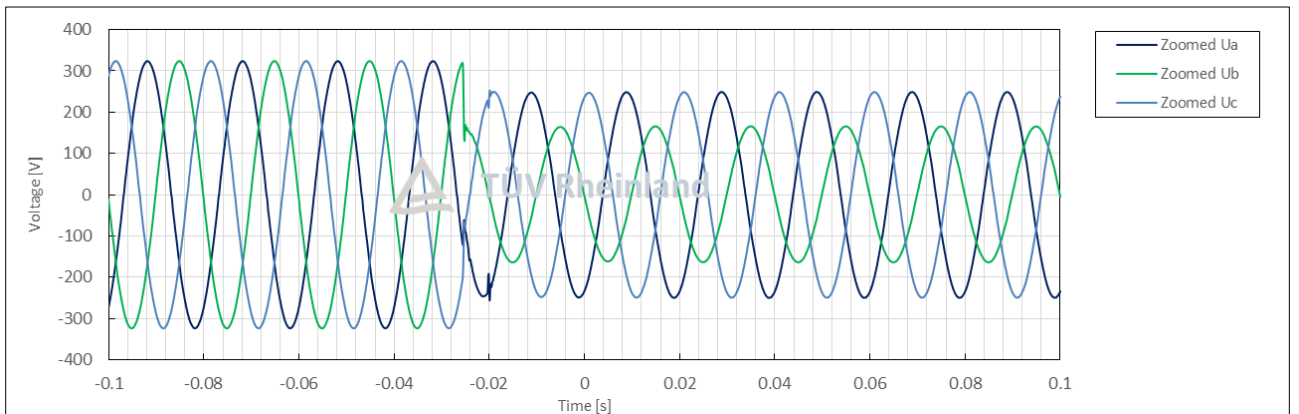
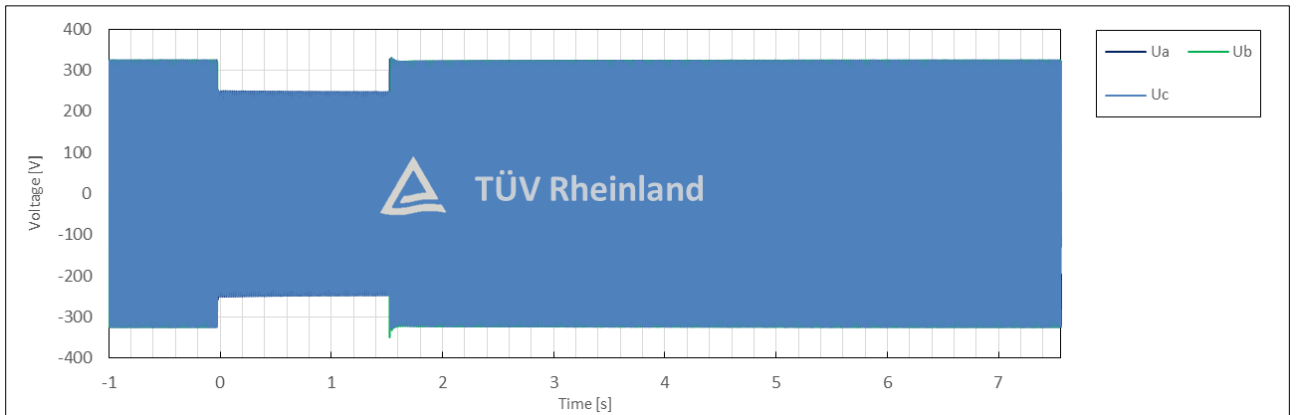

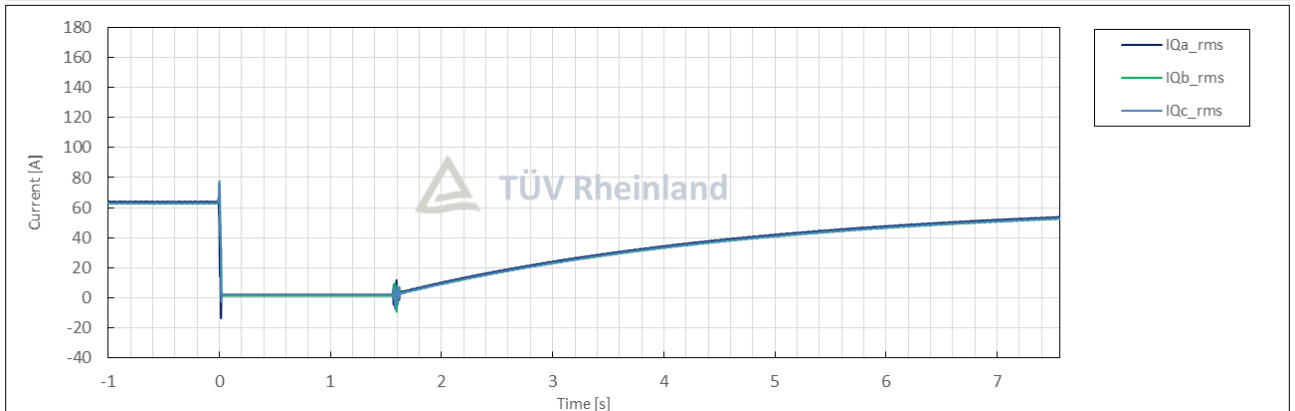
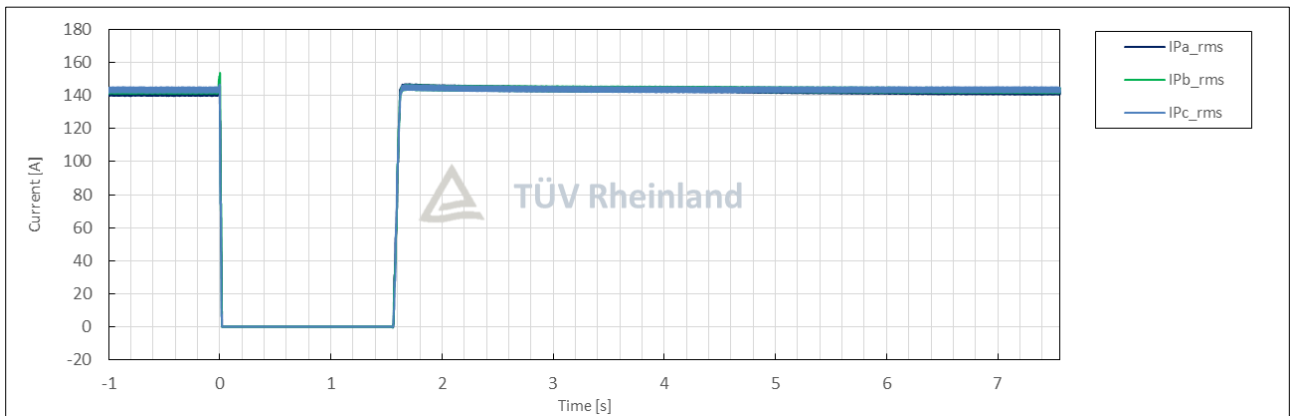
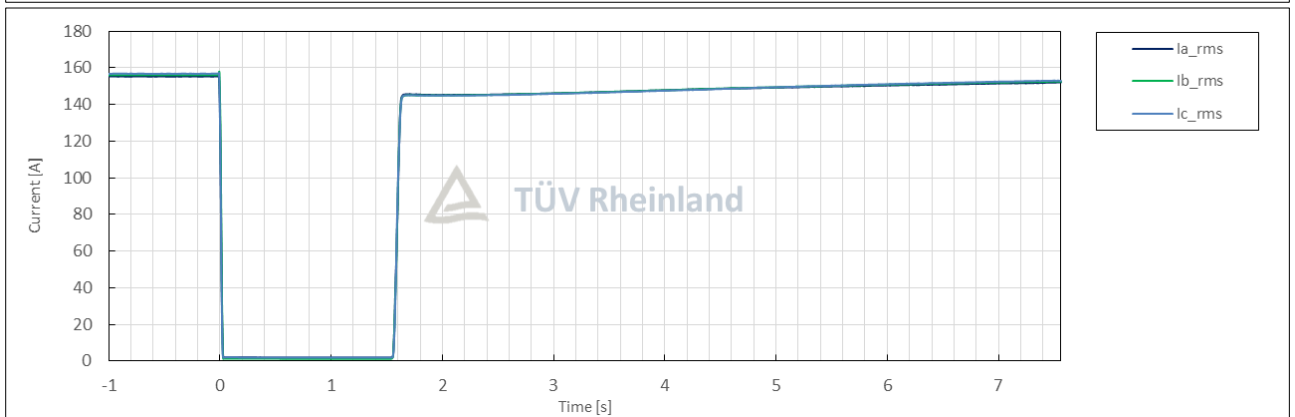
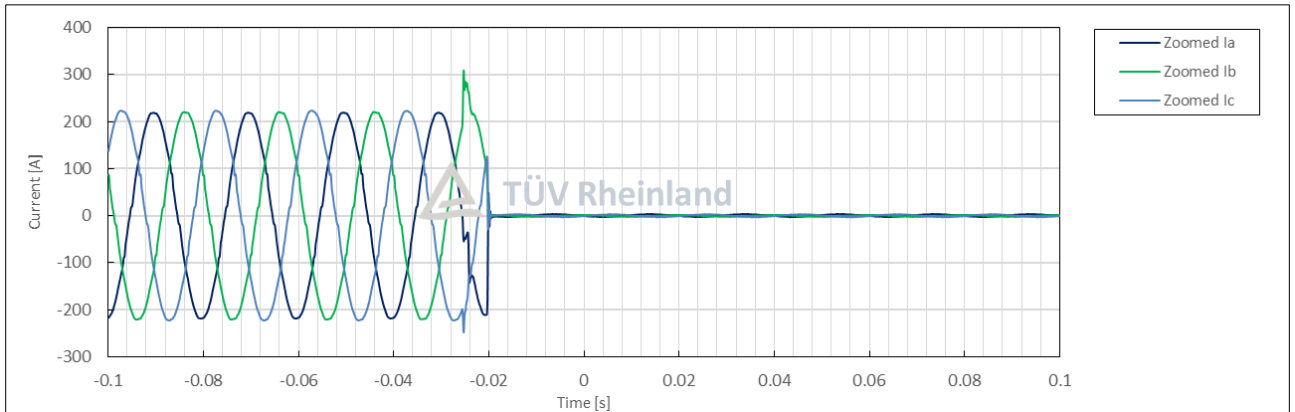

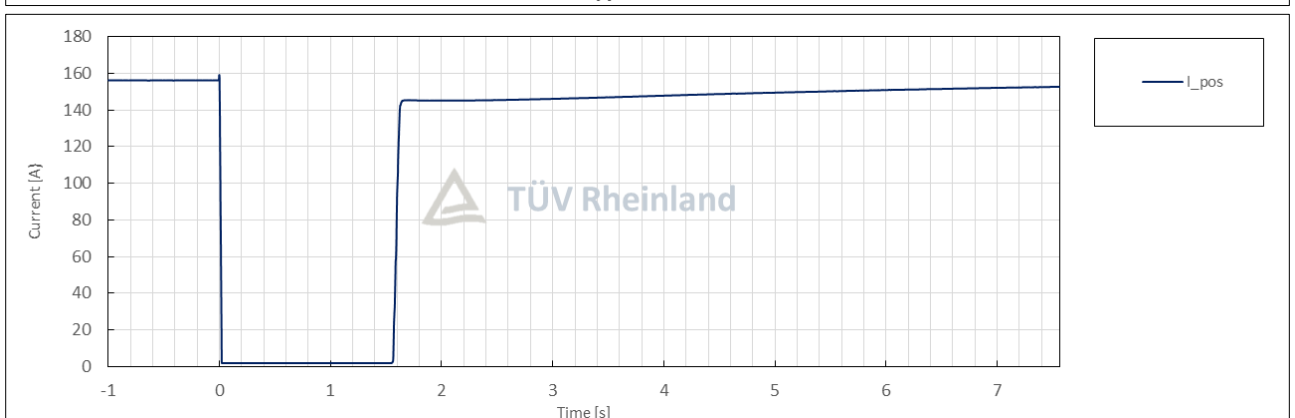
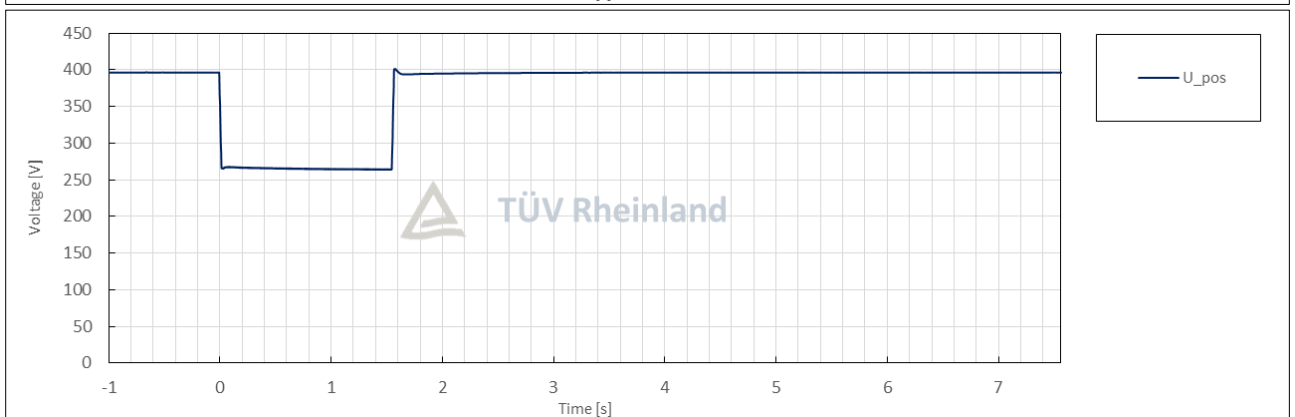
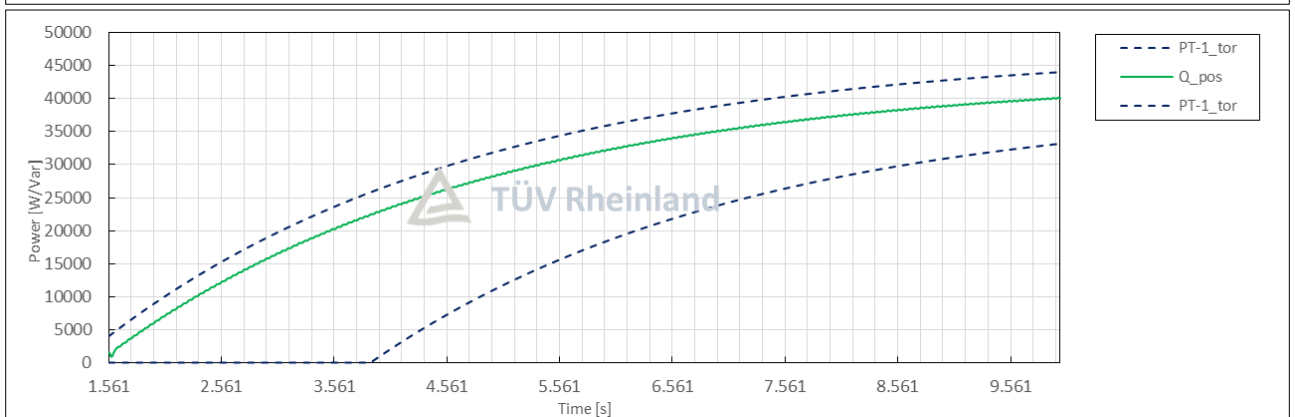
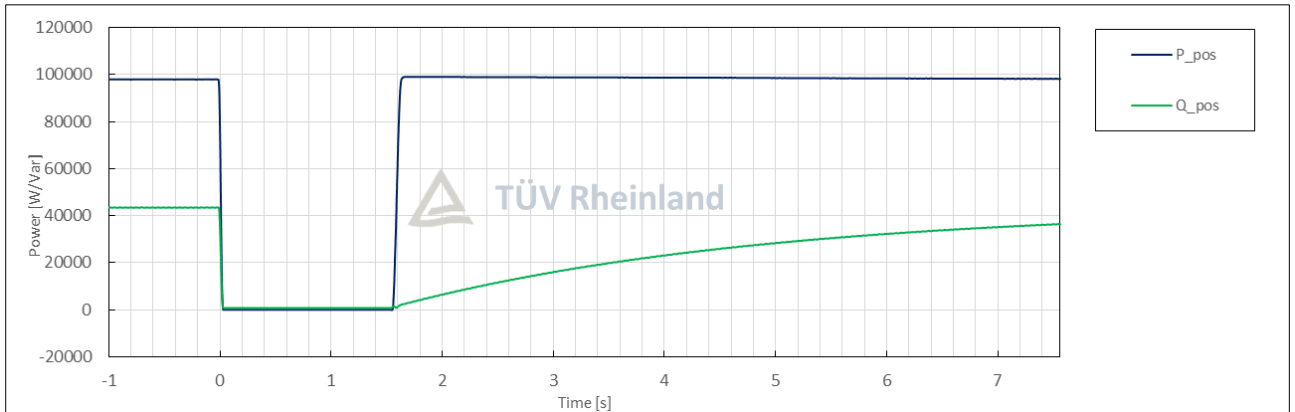

Condition						Measurement
No.	Parameter	Phase ref.	Time ref.	unit		
General Info.	0	Test number	--	--	--	2.4
	1	Date	--	--	dd.mm.yyyy	28.07.2025
	2	Time (start of test)	--	--	hh:mm:ss.f	13:50:15
	3	Fault type (phase)	--	--		2-phase fault
	4	Setting voltage depth	Line to line	--	p.u.	0.50
	5	Setting dip duration		--		1561
	6	Point of fault entry	Total	--	ms	0
	7	Point of fault clearance	Total	--	ms	1561
	8	Fault duration in empty load test	Total	--	ms	1561
	9	Voltage depth/height in empty load test	Total	t1+100ms to t2 and t1-10s to t1	p.u.	0.50
10	Pos.		p.u.		0.67	
Before dip <t1	11	Voltage	Line to neutral	t1-100s to t1	p.u.	1.00
	12	Current	Pos.	t1-500ms to t1-100ms	p.u.	0.52
	13	Active power	Total	t1-10s to t1	p.u.	0.29
	14		Pos.			0.29
	15	Reactive power	Total	t1-10s to t1	p.u.	0.42
	16		Pos.			0.42
17	Cos ϕ	--	t1-10s to t1	--	0.563	
During dip t1 to t2	18	Voltage	Line to neutral	t1+100ms to t2-20ms	p.u.	0.50
	19	Line current	Phase 1	t1+60ms	p.u.	0.01
	20		Phase 2			0.01
	21		Phase 3			0.01
	22	Line current	Phase 1	t1+100ms	p.u.	0.01
	23		Phase 2			0.01
	24		Phase 3			0.01
	25	Active power	Total	t1+100ms to t2-20ms	p.u.	0.00
26	Pos.		0.00			
After dip > t2	27	Voltage	Line to neutral	t2+3s to t2+10s	p.u.	1.00
	28	Active power	Total	t2+3s to t2+10s	p.u.	0.29
	29		Pos.			0.29
	39	Active power rising time	Pos.	--	s	0.027
	31	Reactive power	Total	t2+3s to t2+10s	p.u.	0.35
	32		Pos.			0.35
	33	Reactive power rising time	Pos.	--	s	9.968
34	PGU does not disconnect from grid till 60s after fault	--	t2 to t2+60s	Yes / No	No	

Test No. 2.4 idle test

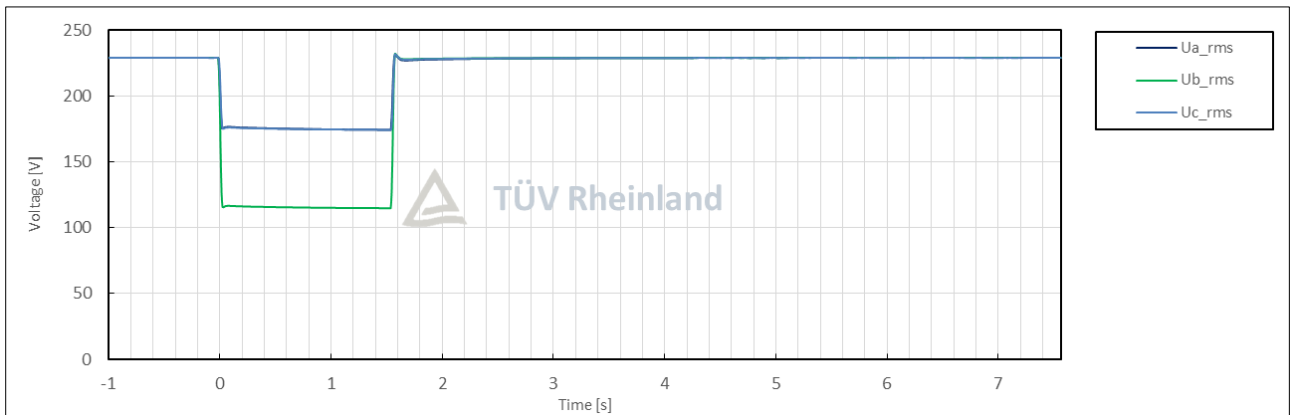
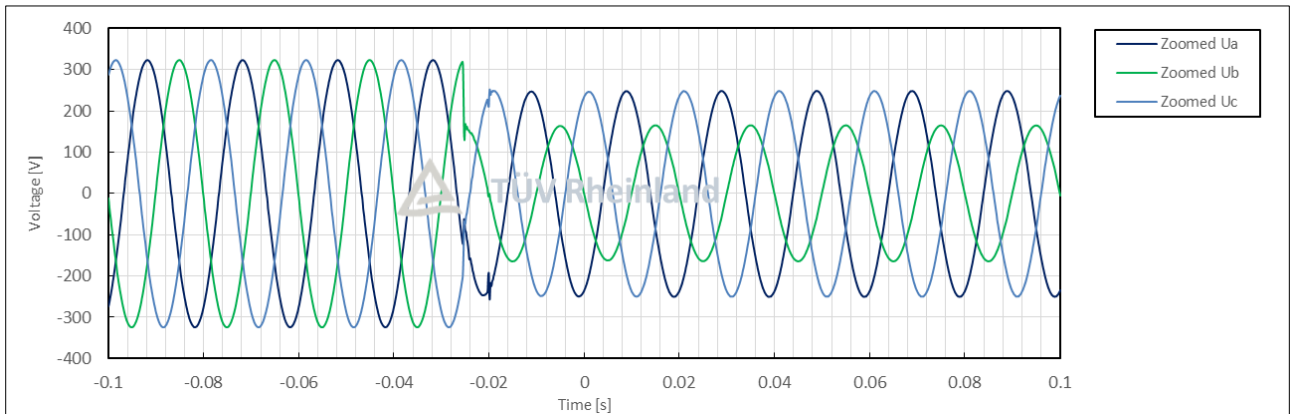
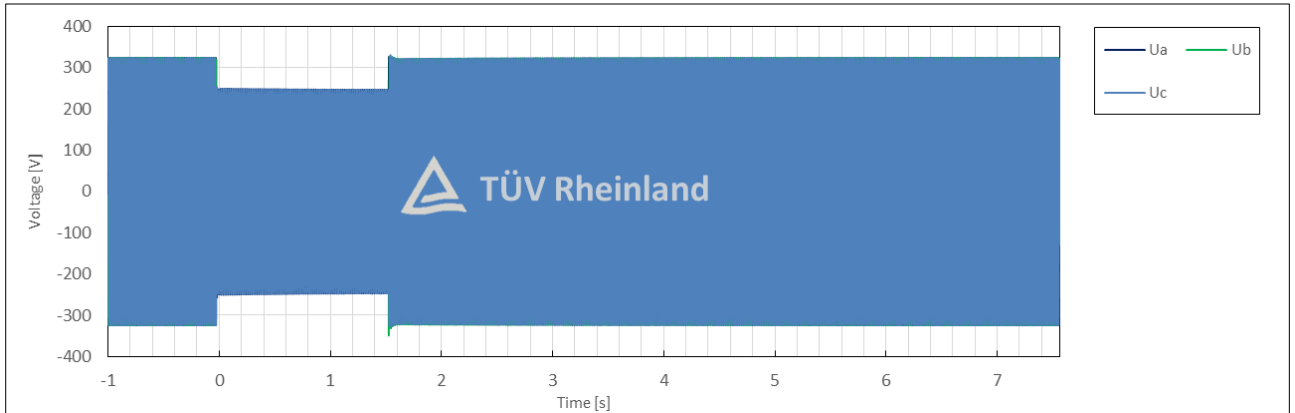

Test No. 2.4 with PGU

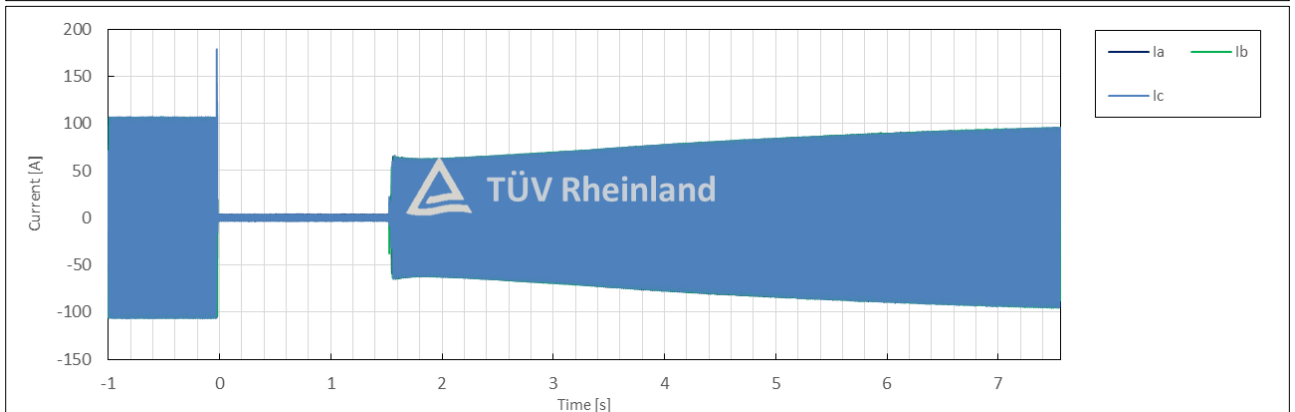
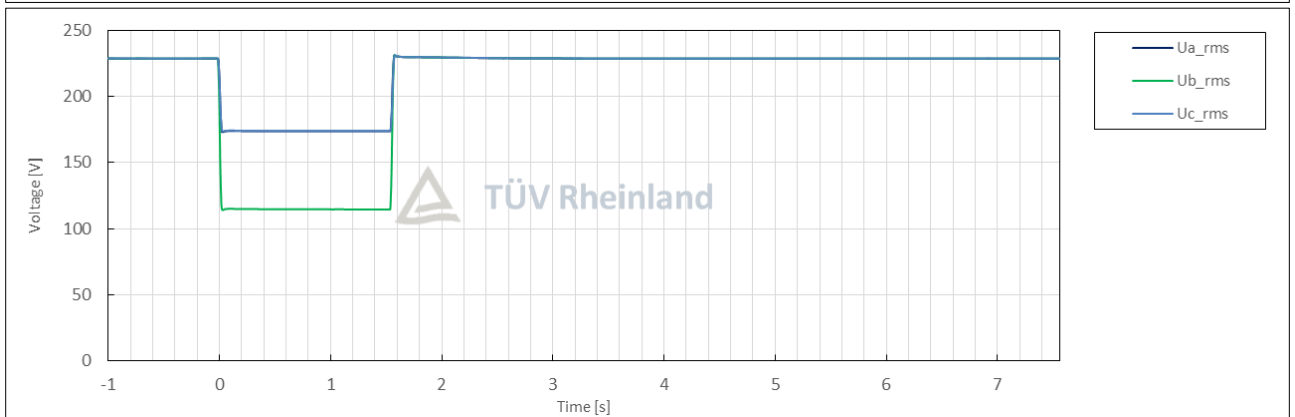
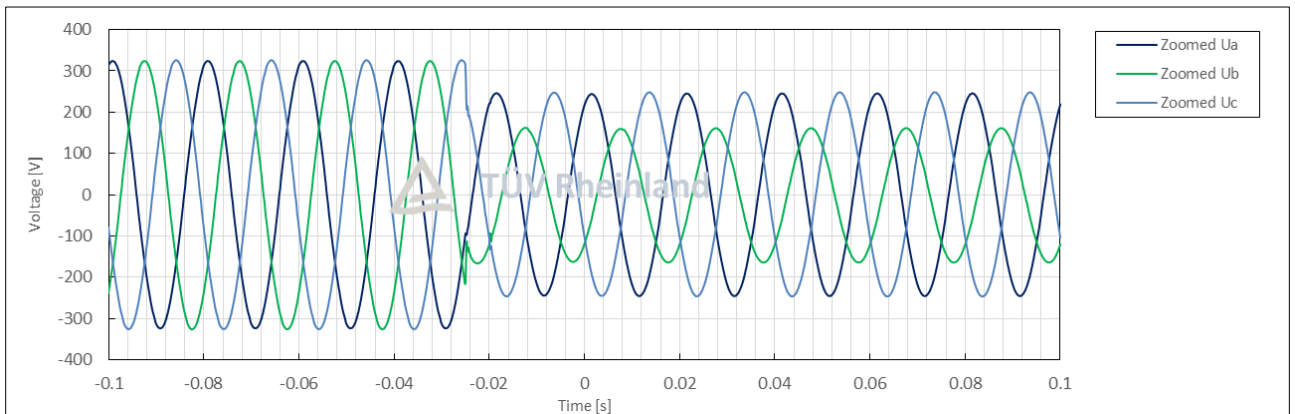
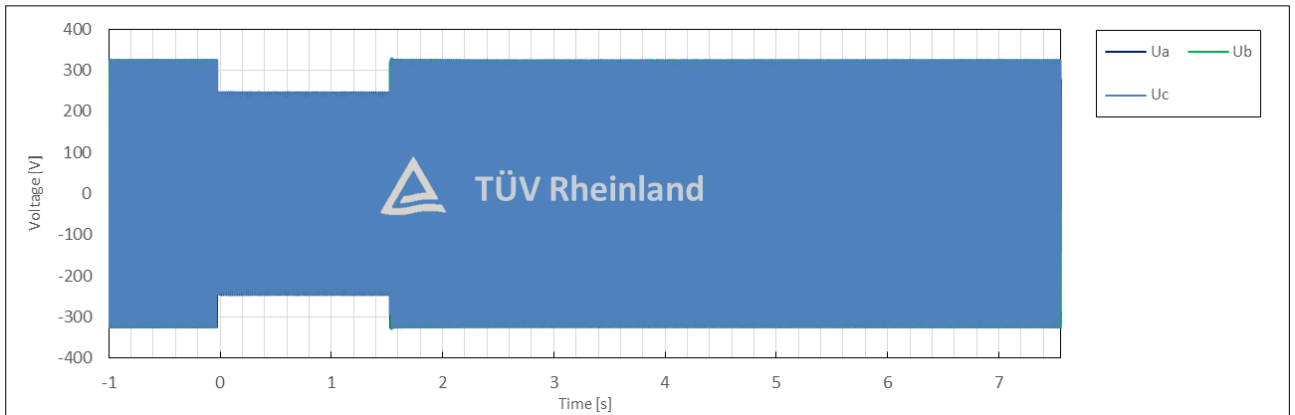

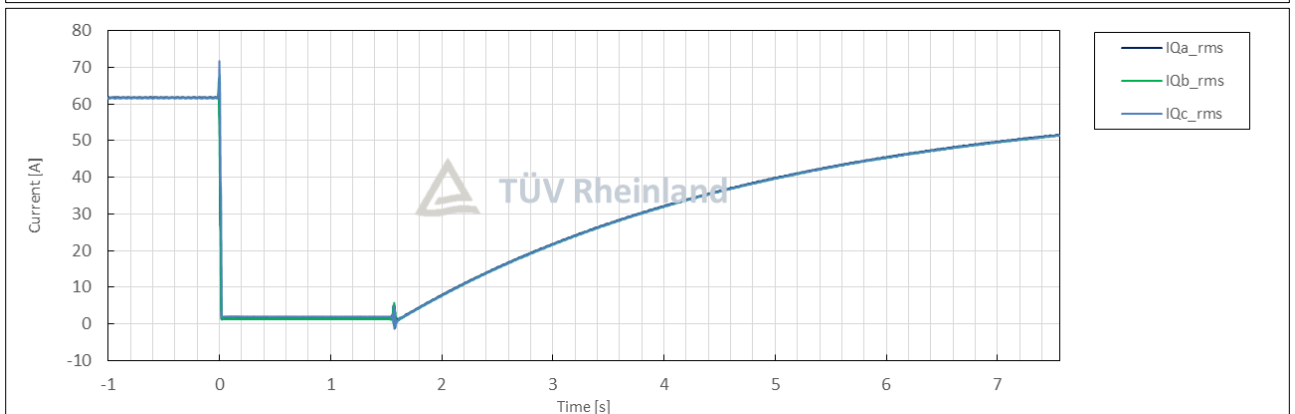
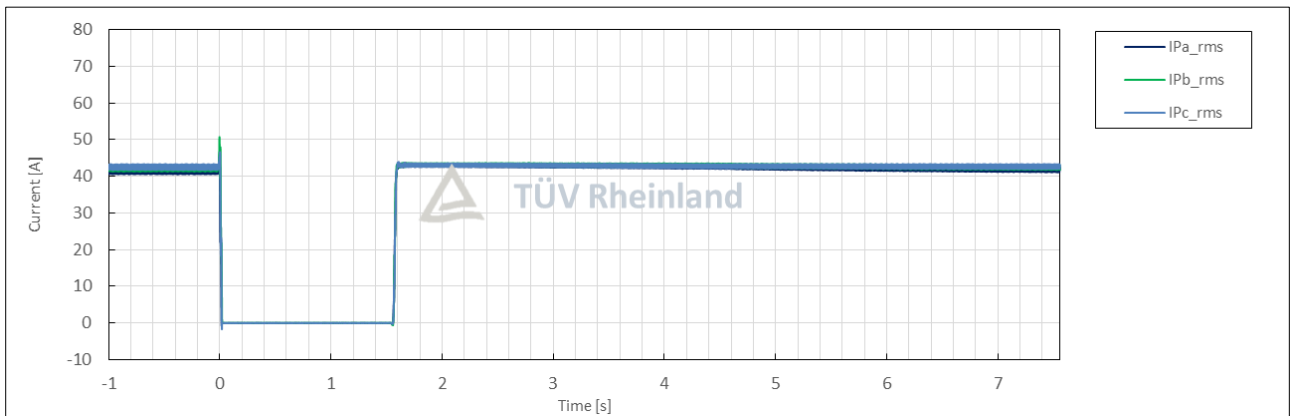
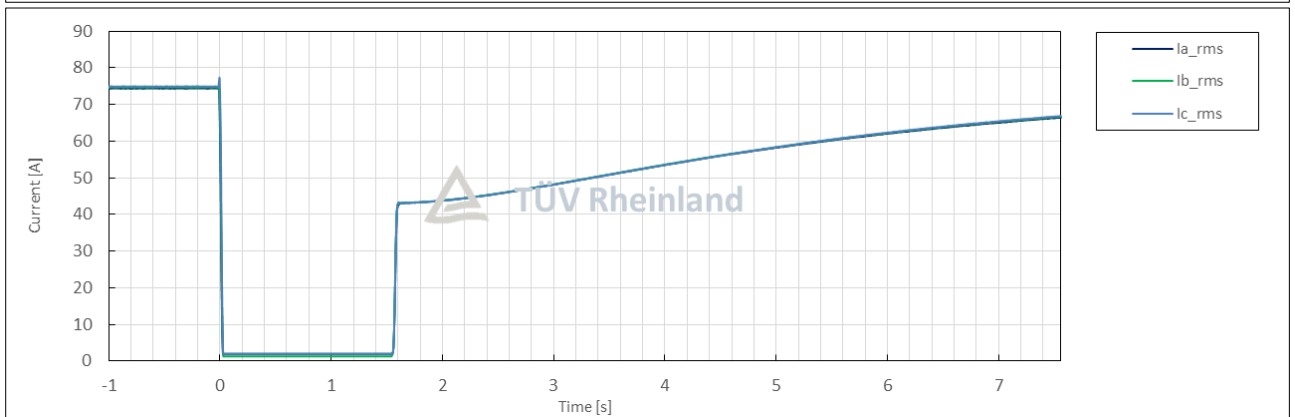
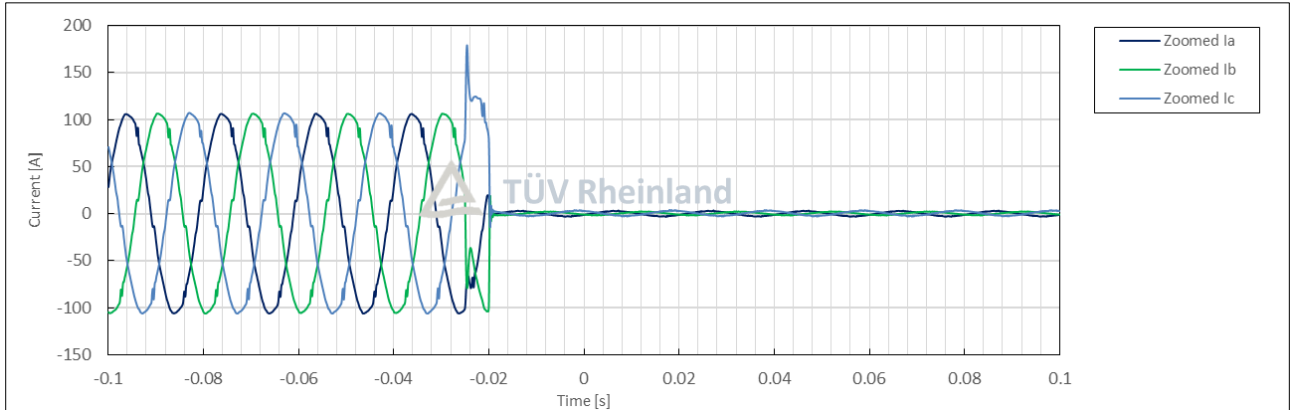

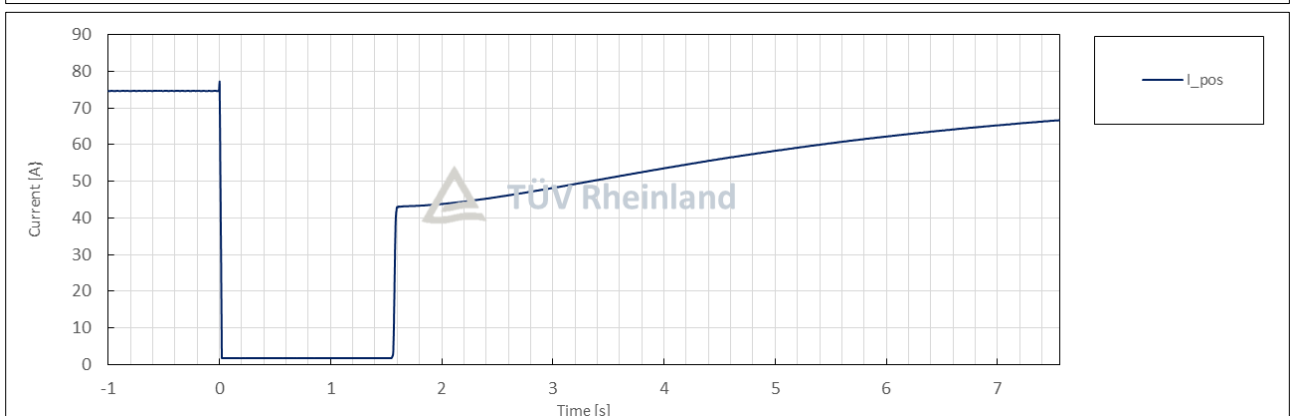
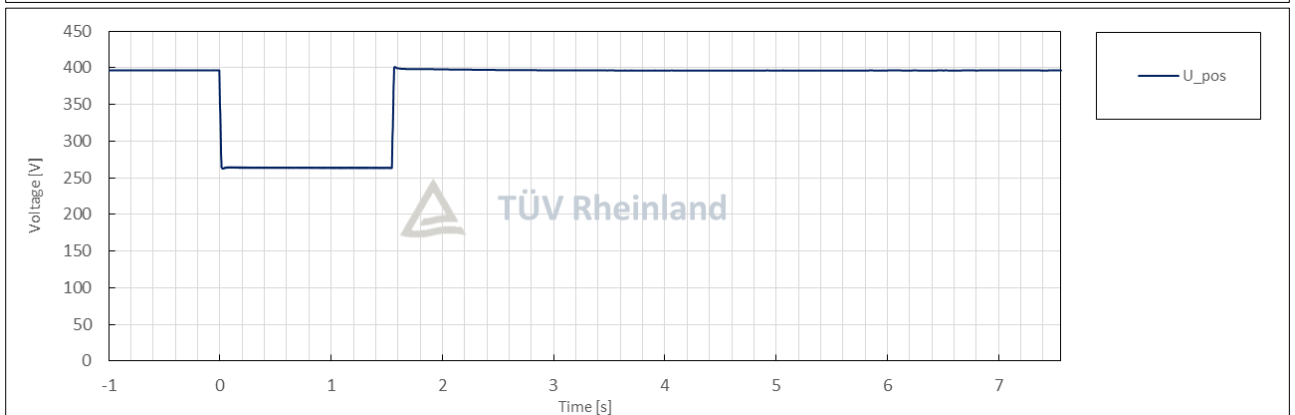
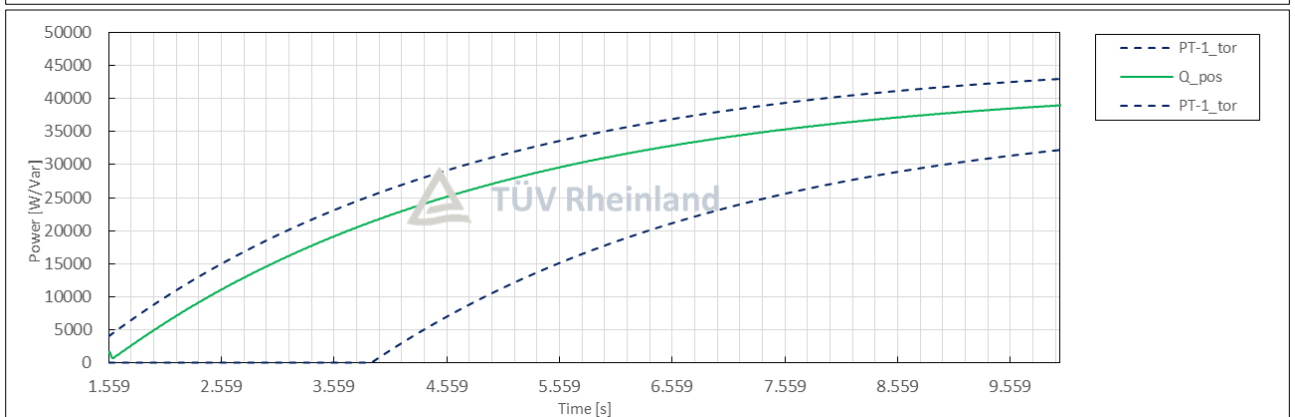
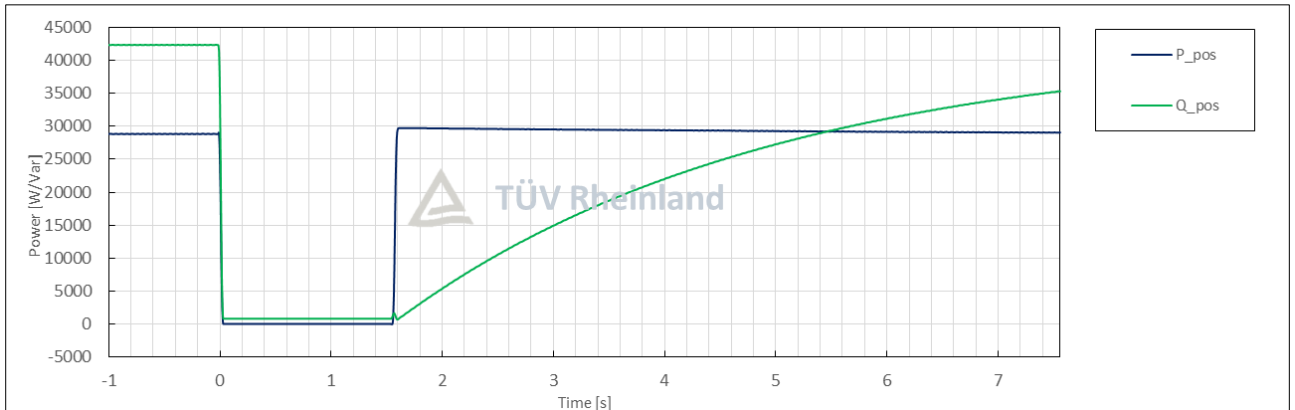

Prüfbericht-Nr.: CN25J408 002 Attachment 1
Test report no.:

Seite 77 von 181
 Page 77 of 181

Condition						Measurement
No.	Parameter	Phase ref.	Time ref.	unit		
General Info.	0	Test number	--	--	--	3.1
	1	Date	--	--	dd.mm.yyyy	28.07.2025
	2	Time (start of test)	--	--	hh:mm:ss.f	13:50:30
	3	Fault type (phase)	--	--		3-phase fault
	4	Setting voltage depth	Line to line	--	p.u.	0.50
	5	Setting dip duration		--		1552
	6	Point of fault entry	Total	--	ms	0
	7	Point of fault clearance	Total	--	ms	1552
	8	Fault duration in empty load test	Total	--	ms	1552
	9	Voltage depth/height in empty load test	Total	t1+100ms to t2 and t1-10s to t1	p.u.	0.50
10	Pos.		p.u.		0.51	
Before dip <t1	11	Voltage	Line to neutral	t1-100s to t1	p.u.	1.00
	12	Current	Pos.	t1-500ms to t1-100ms	p.u.	1.09
	13	Active power	Total	t1-10s to t1	p.u.	1.00
	14		Pos.			1.00
	15	Reactive power	Total	t1-10s to t1	p.u.	-0.43
	16		Pos.			-0.43
17	Cos ϕ	--	t1-10s to t1	--	0.917	
During dip t1 to t2	18	Voltage	Line to neutral	t1+100ms to t2-20ms	p.u.	0.50
	19	Line current	Phase 1	t1+60ms	p.u.	0.01
	20		Phase 2			0.01
	21		Phase 3			0.01
	22	Line current	Phase 1	t1+100ms	p.u.	0.01
	23		Phase 2			0.01
	24		Phase 3			0.01
	25	Active power	Total	t1+100ms to t2-20ms	p.u.	0.00
26	Pos.		0.00			
After dip > t2	27	Voltage	Line to neutral	t2+3s to t2+10s	p.u.	1.00
	28	Active power	Total	t2+3s to t2+10s	p.u.	1.00
	29		Pos.			1.00
	39	Active power rising time	Pos.	--	s	0.053
	31	Reactive power	Total	t2+3s to t2+10s	p.u.	-0.36
	32		Pos.			-0.36
	33	Reactive power rising time	Pos.	--	s	10.042
34	PGU does not disconnect from grid till 60s after fault	--	t2 to t2+60s	Yes / No	No	

Test No. 3.1 idle test

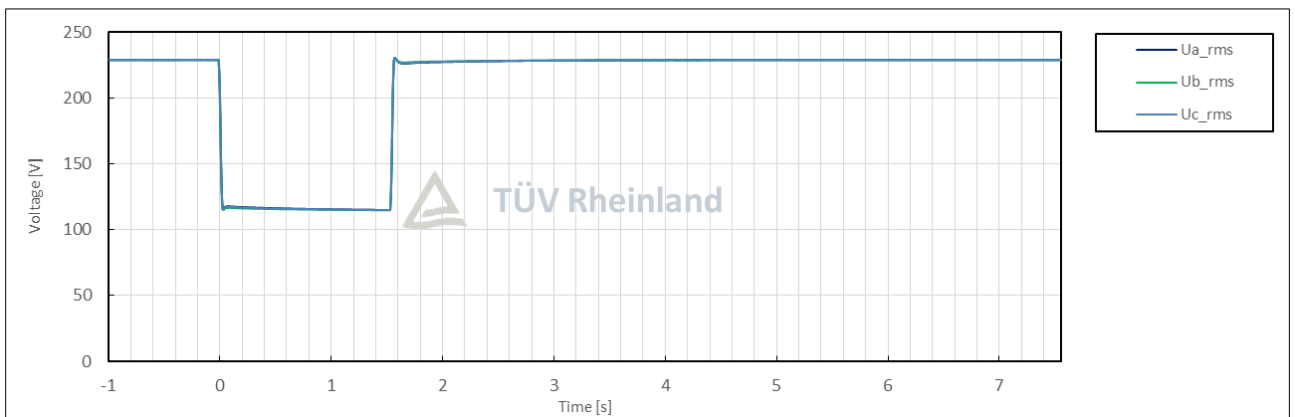
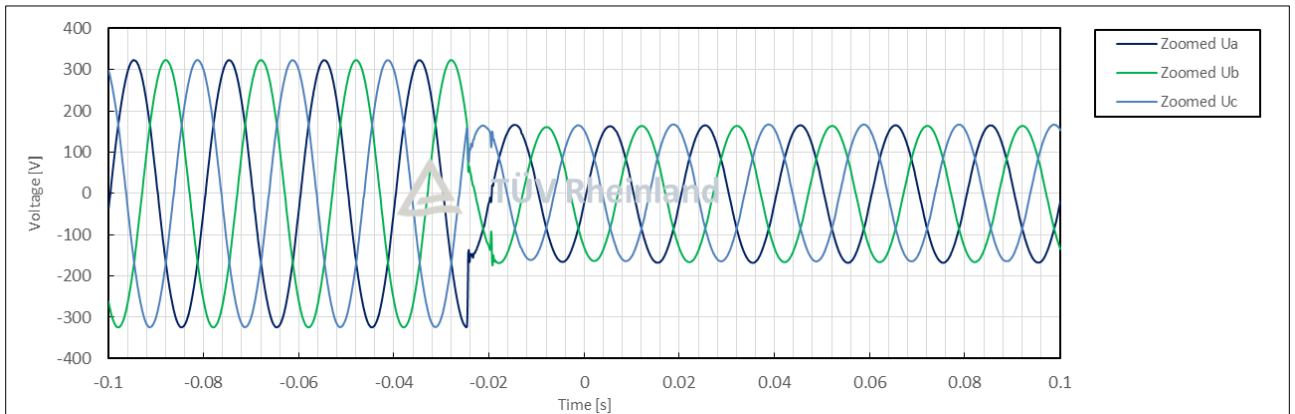
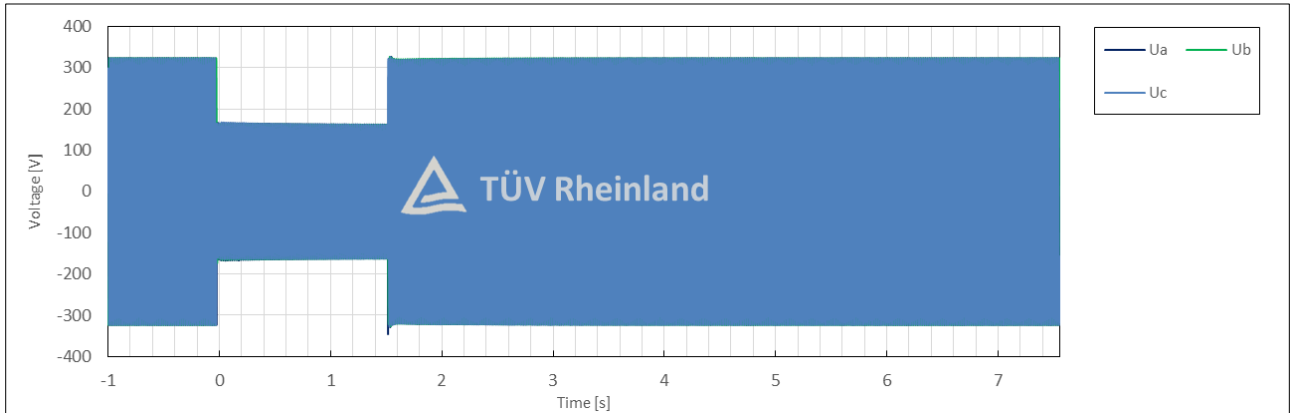

Test No. 3.1 with PGU

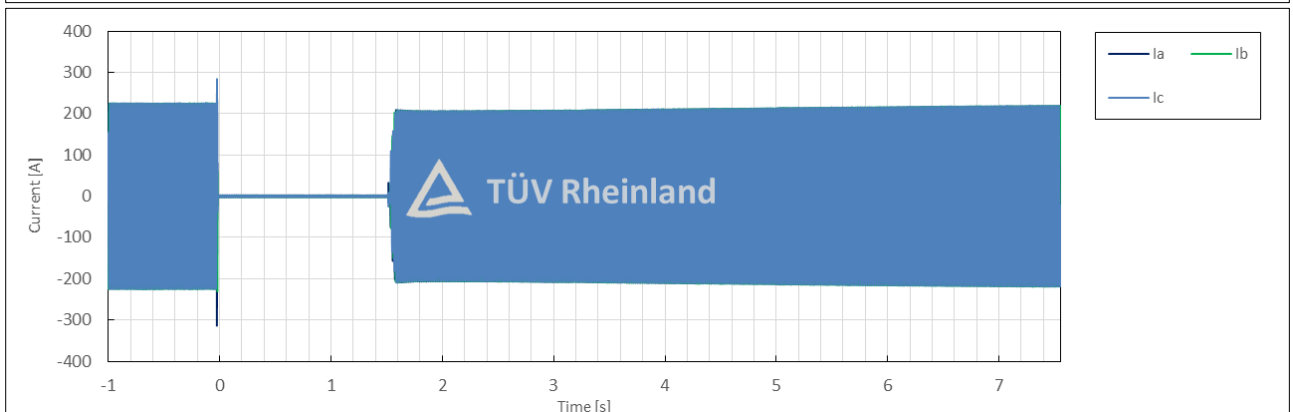
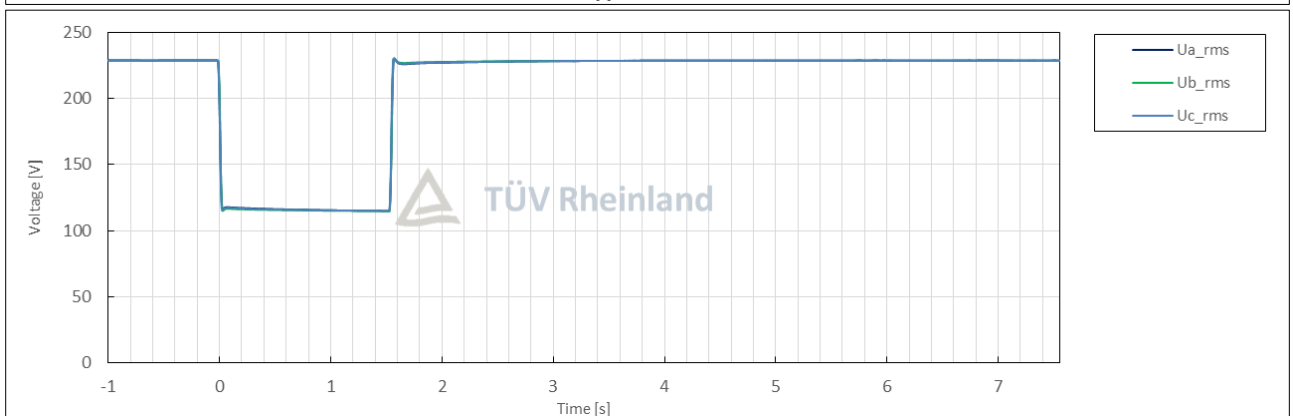
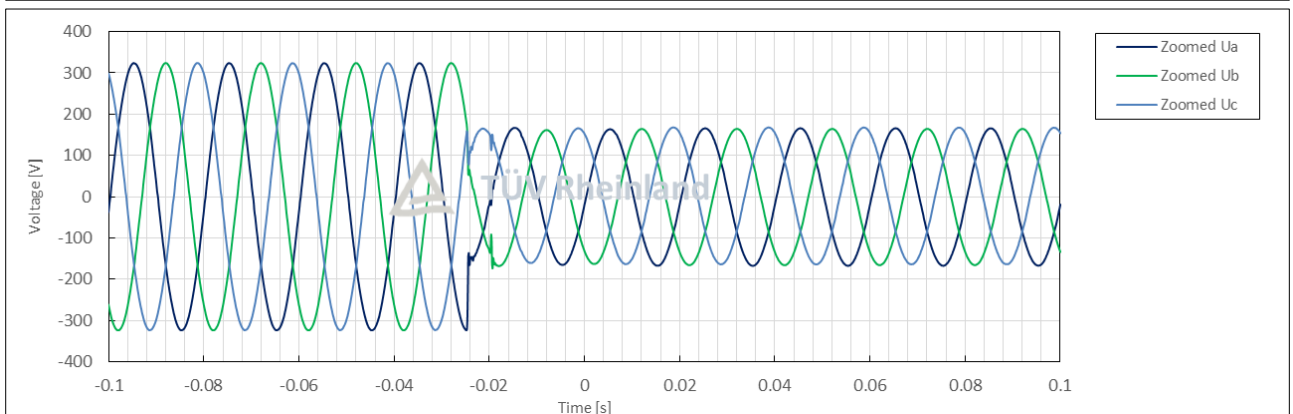
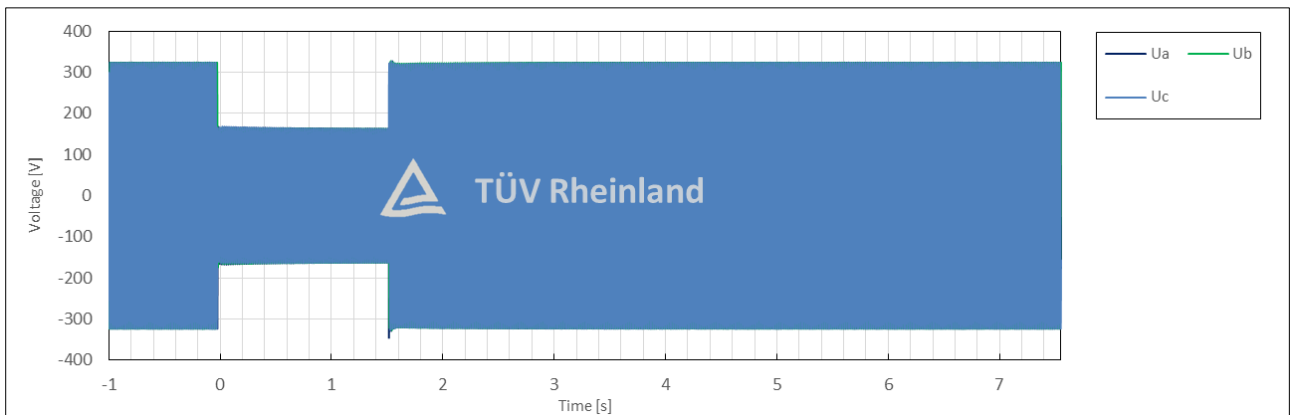

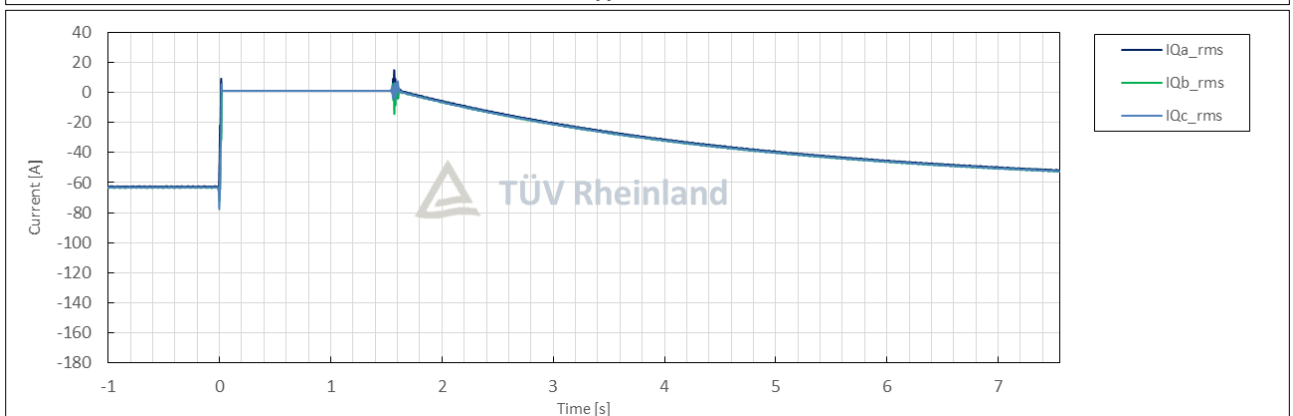
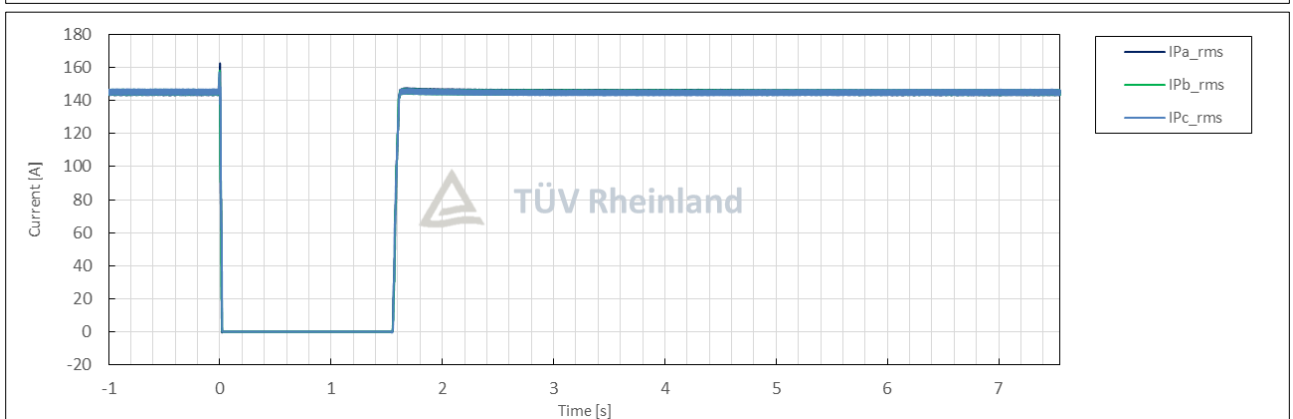
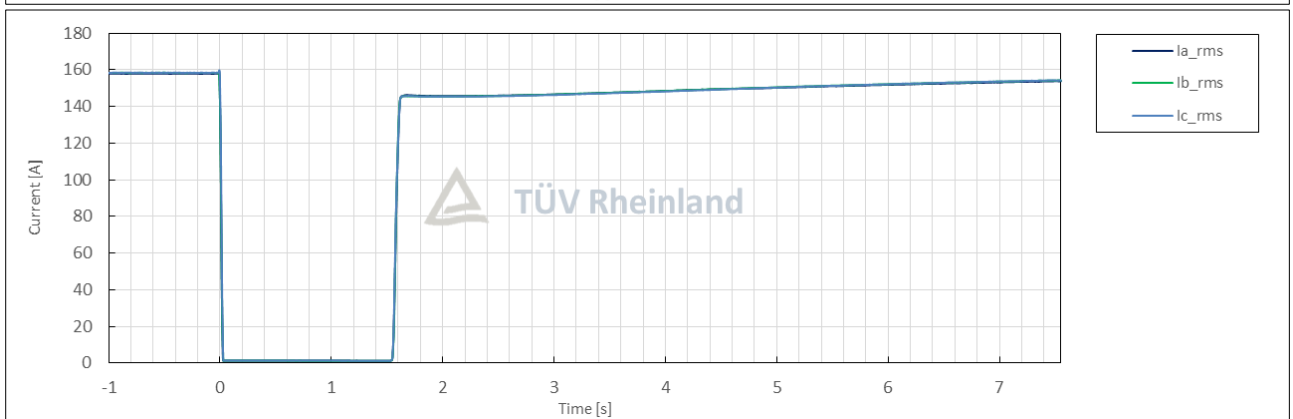
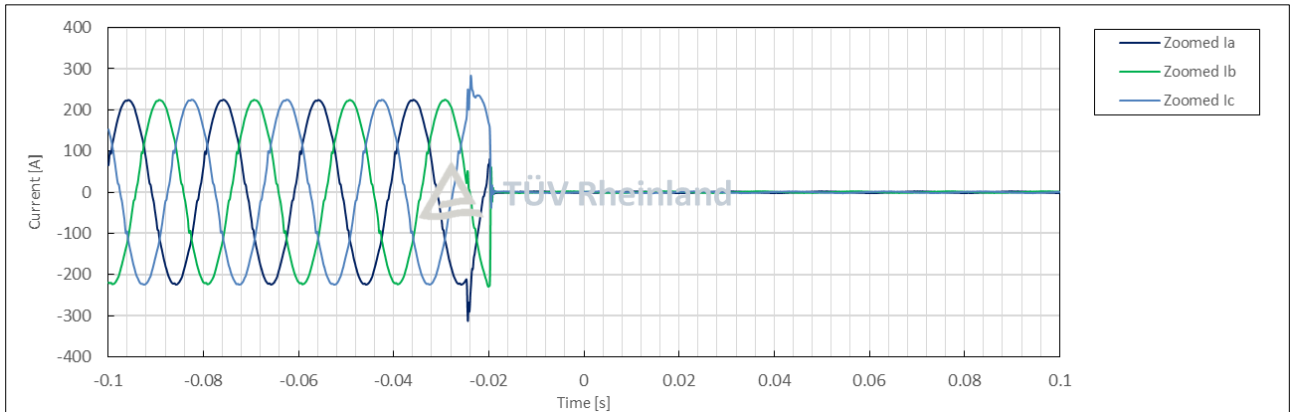

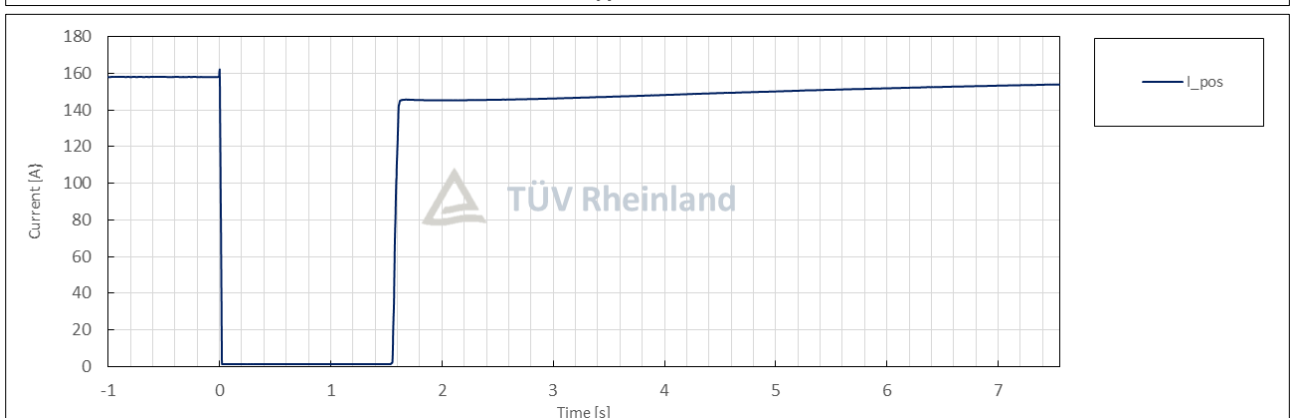
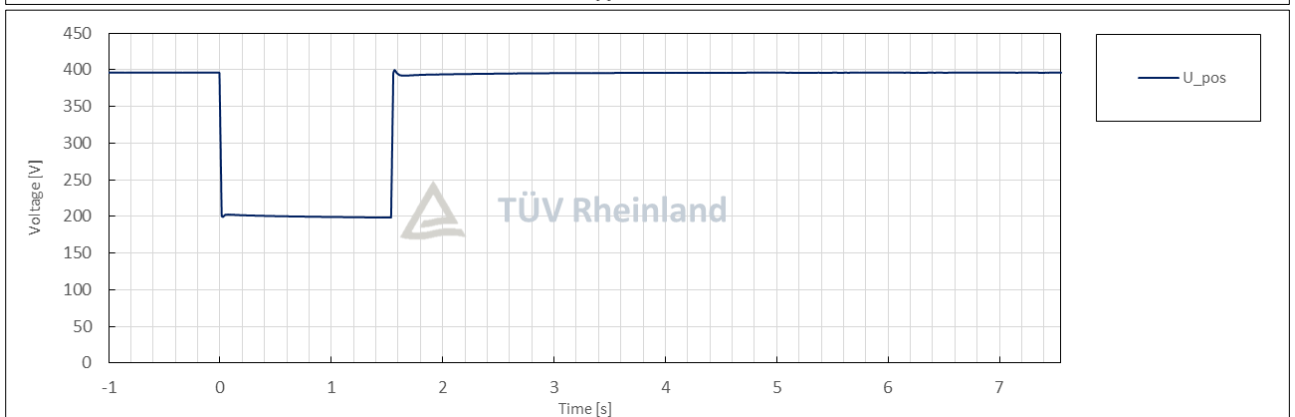
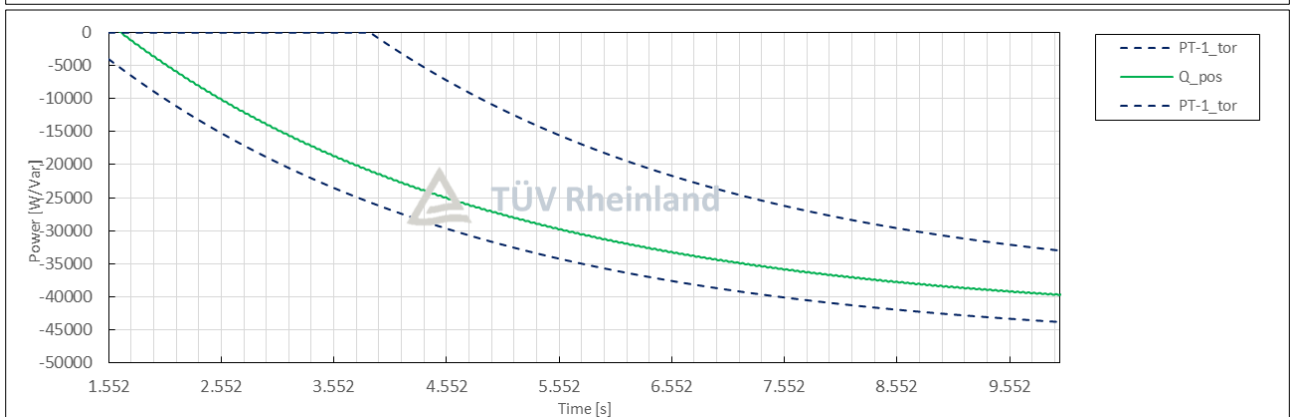
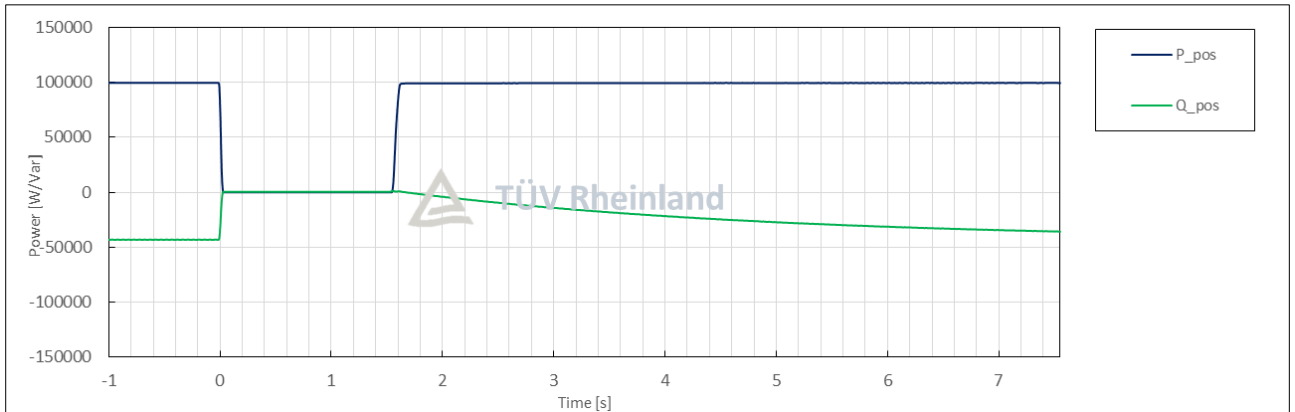

Prüfbericht-Nr.: CN25J408 002 Attachment 1
Test report no.:

Seite 82 von 181
Page 82 of 181

Condition						Measurement
No.	Parameter	Phase ref.	Time ref.	unit		
General Info.	0	Test number	--	--	--	3.2
	1	Date	--	--	dd.mm.yyyy	28.07.2025
	2	Time (start of test)	--	--	hh:mm:ss.f	13:50:38
	3	Fault type (phase)	--	--		3-phase fault
	4	Setting voltage depth	Line to line	--	p.u.	0.50
	5	Setting dip duration		--		1552
	6	Point of fault entry	Total	--	ms	0
	7	Point of fault clearance	Total	--	ms	1552
	8	Fault duration in empty load test	Total	--	ms	1552
	9	Voltage depth/height in empty load test	Total	t1+100ms to t2 and t1-10s to t1	p.u.	0.50
	10		Pos.		p.u.	0.51
Before dip <t1	11	Voltage	Line to neutral	t1-100s to t1	p.u.	0.99
	12	Current	Pos.	t1-500ms to t1-100ms	p.u.	0.53
	13	Active power	Total	t1-10s to t1	p.u.	0.31
	14		Pos.			0.31
	15	Reactive power	Total	t1-10s to t1	p.u.	-0.43
	16		Pos.			-0.43
	17	Cos ϕ	--	t1-10s to t1	--	0.577
During dip t1 to t2	18	Voltage	Line to neutral	t1+100ms to t2-20ms	p.u.	0.50
	19	Line current	Phase 1	t1+60ms	p.u.	0.01
	20		Phase 2			0.01
	21		Phase 3			0.01
	22	Line current	Phase 1	t1+100ms	p.u.	0.01
	23		Phase 2			0.01
	24		Phase 3			0.01
	25	Active power	Total	t1+100ms to t2-20ms	p.u.	0.00
	26		Pos.			0.00
After dip > t2	27	Voltage	Line to neutral	t2+3s to t2+10s	p.u.	0.99
	28	Active power	Total	t2+3s to t2+10s	p.u.	0.30
	29		Pos.			0.30
	39	Active power rising time	Pos.	--	s	0.027
	31	Reactive power	Total	t2+3s to t2+10s	p.u.	-0.36
	32		Pos.			-0.36
	33	Reactive power rising time	Pos.	--	s	10.023
	34	PGU does not disconnect from grid till 60s after fault	--	t2 to t2+60s	Yes / No	No

Test No. 3.2 idle test

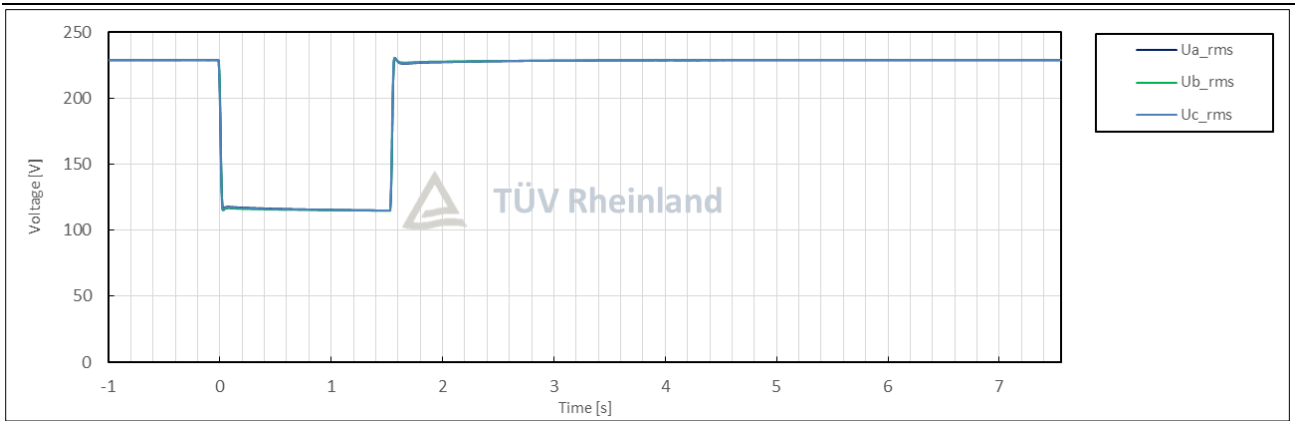
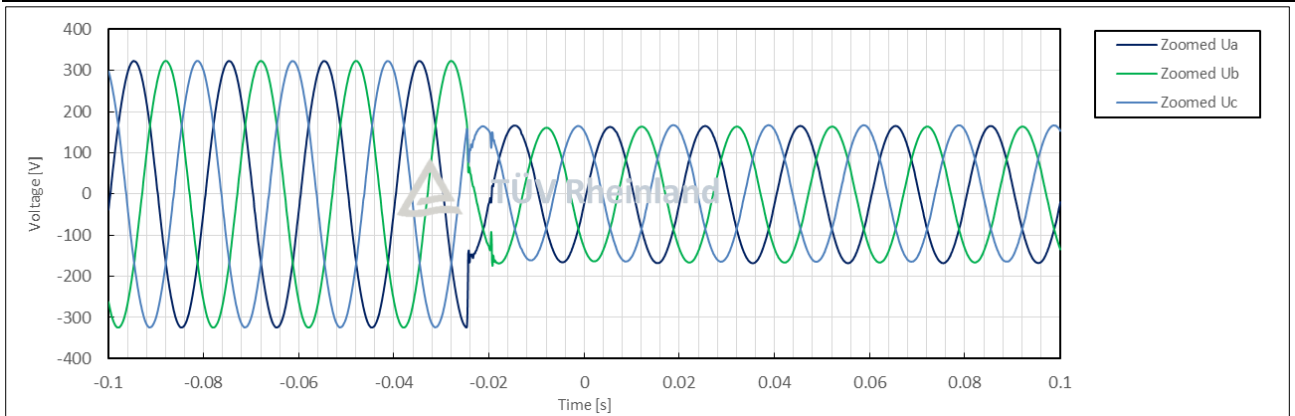
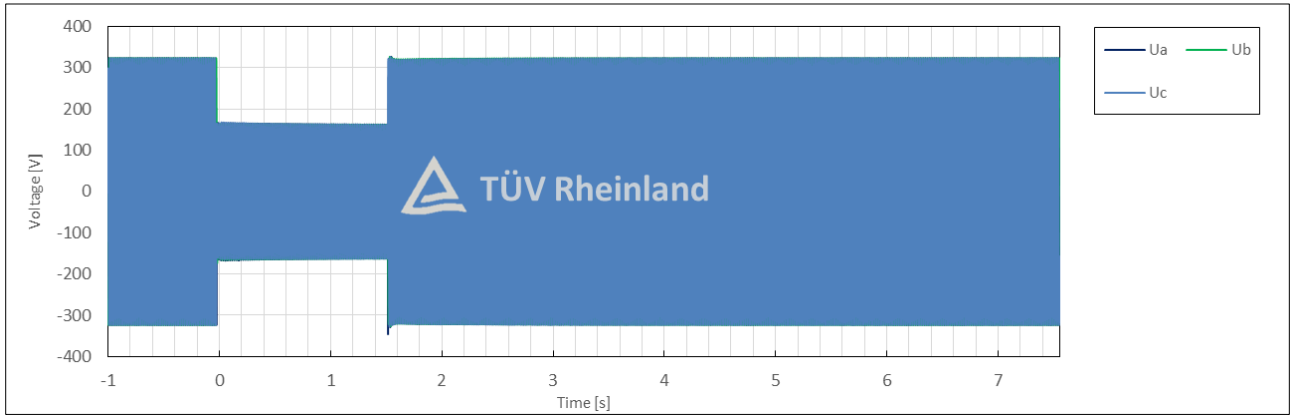

Test No. 3.2 with PGU

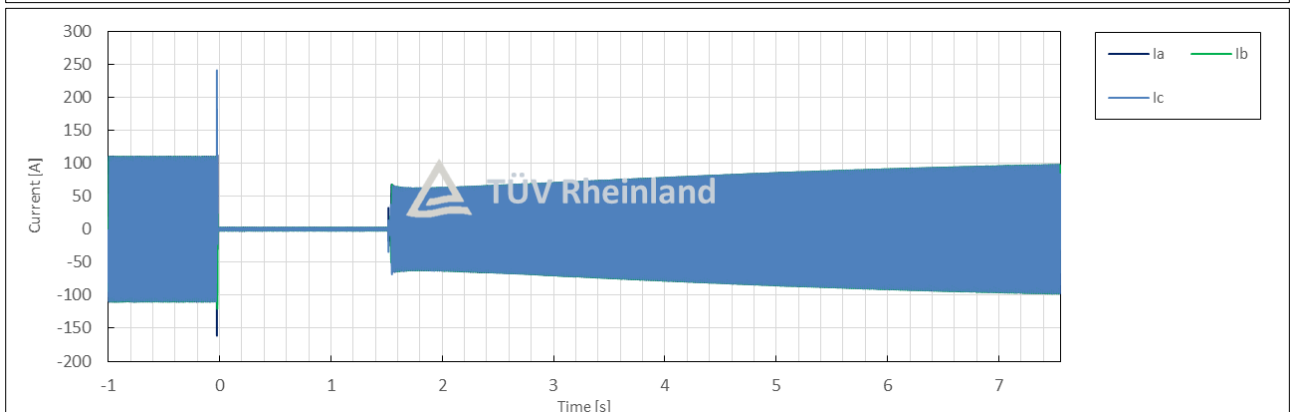
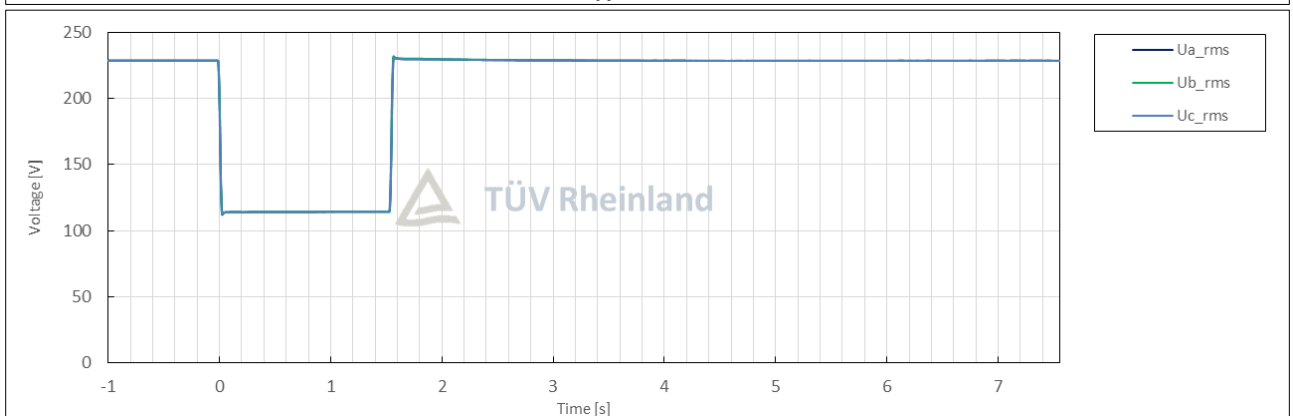
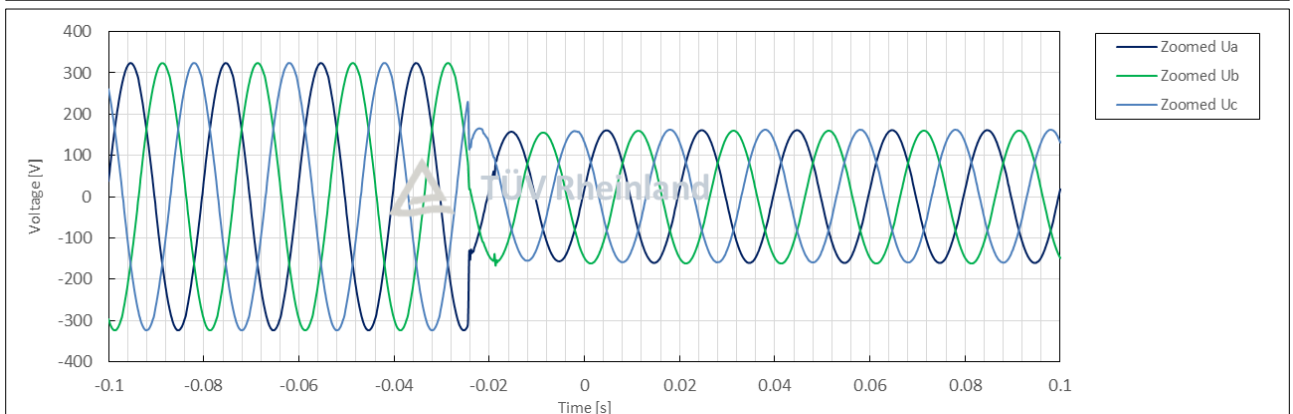
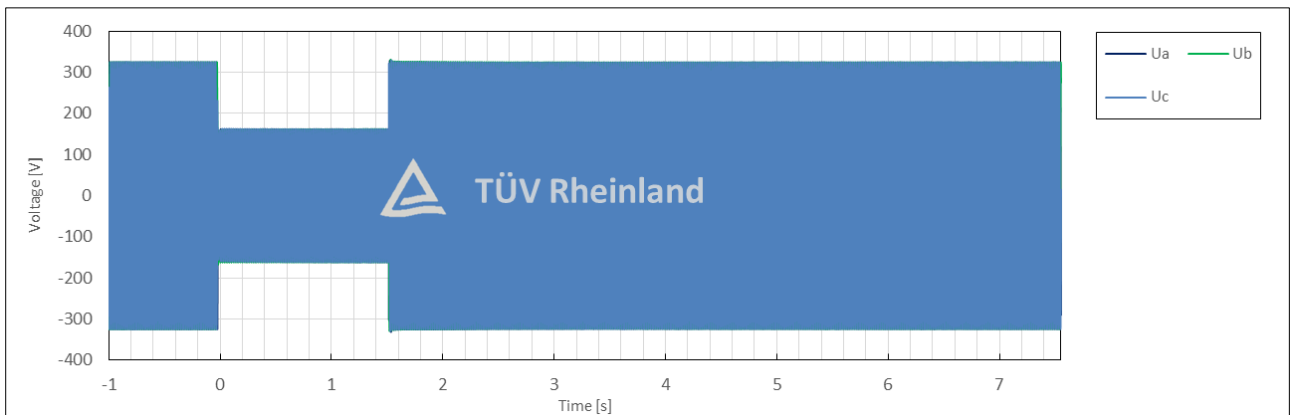

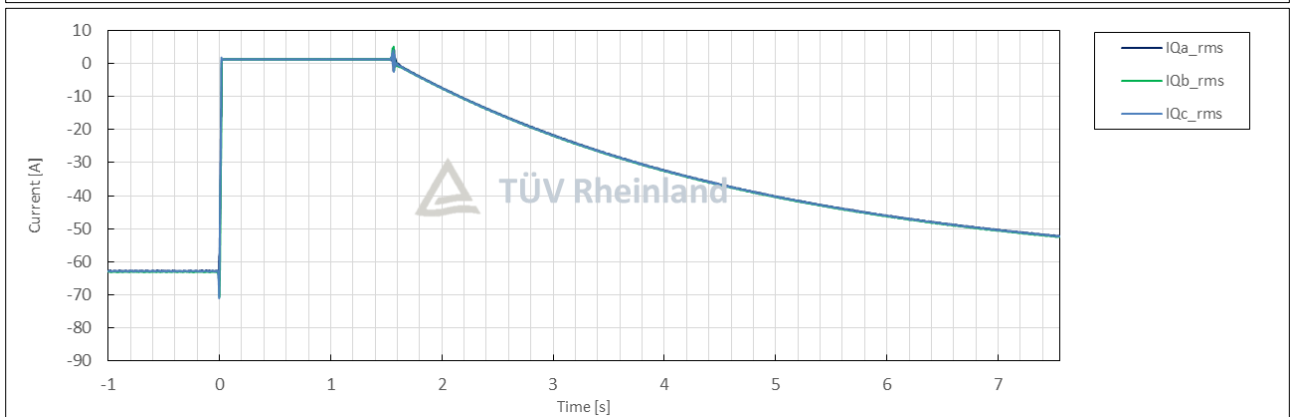
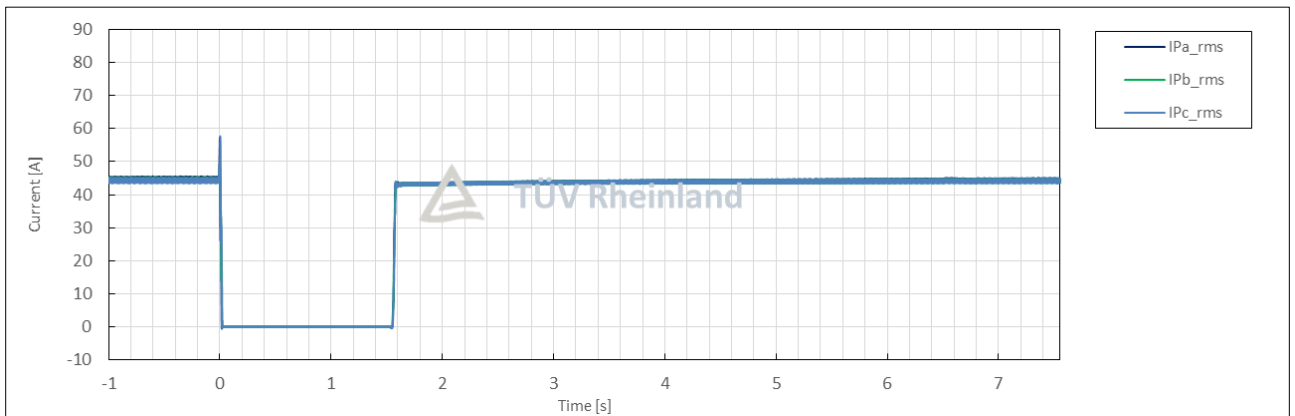
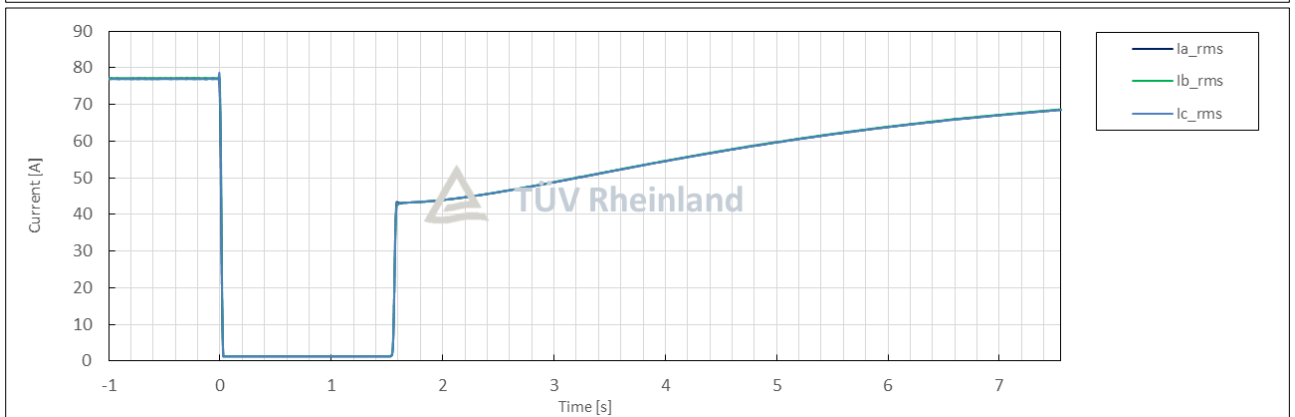
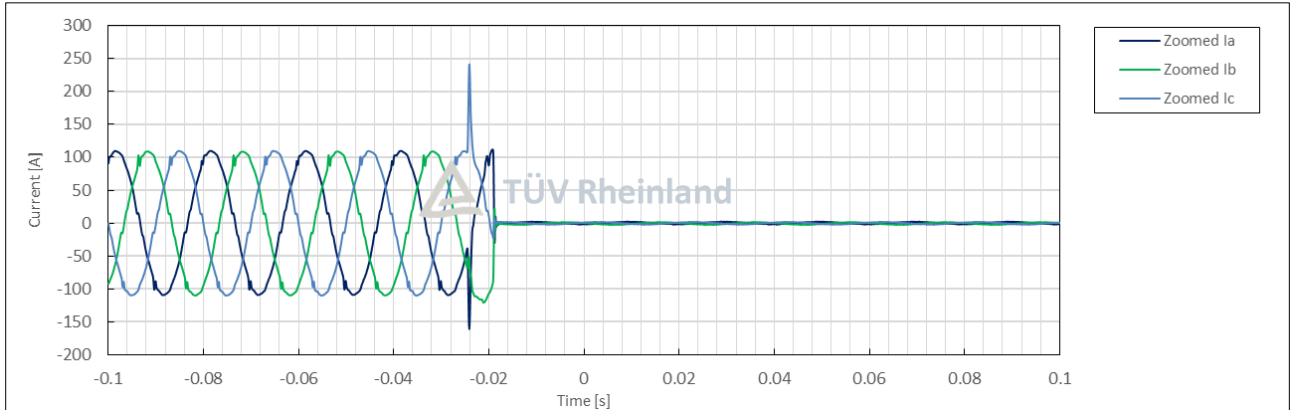

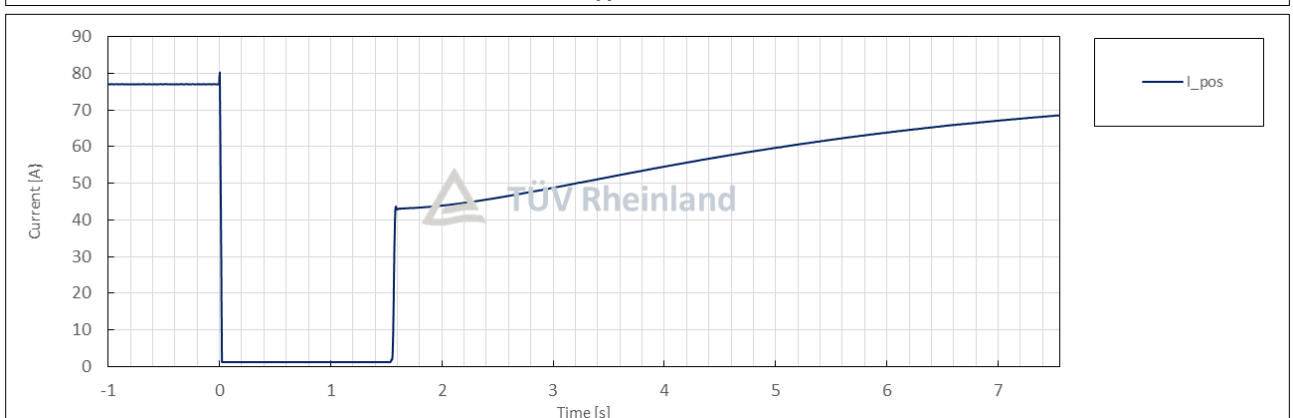
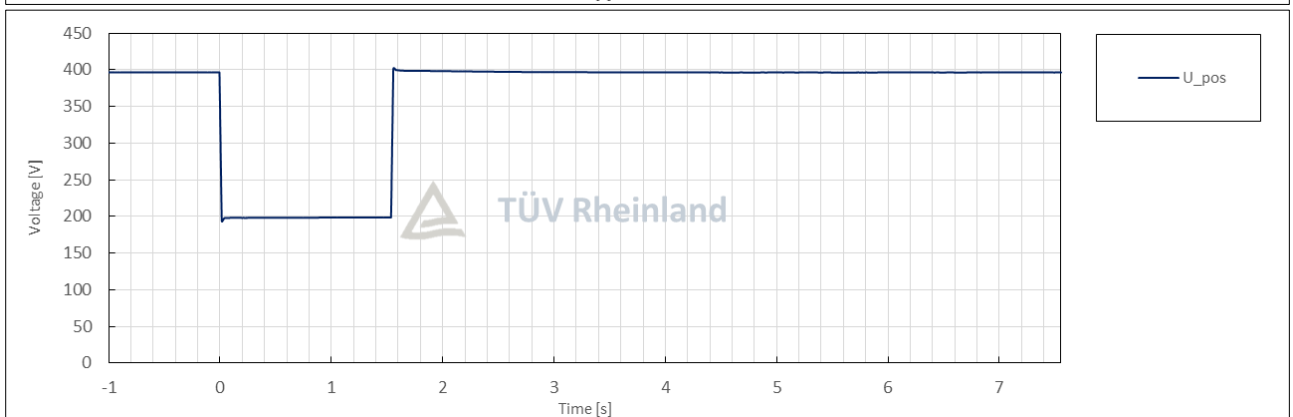
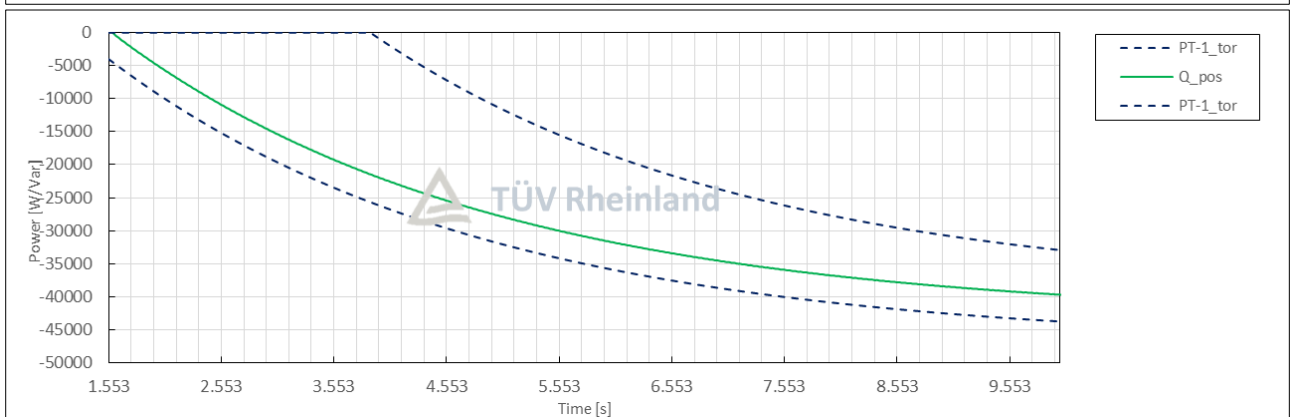
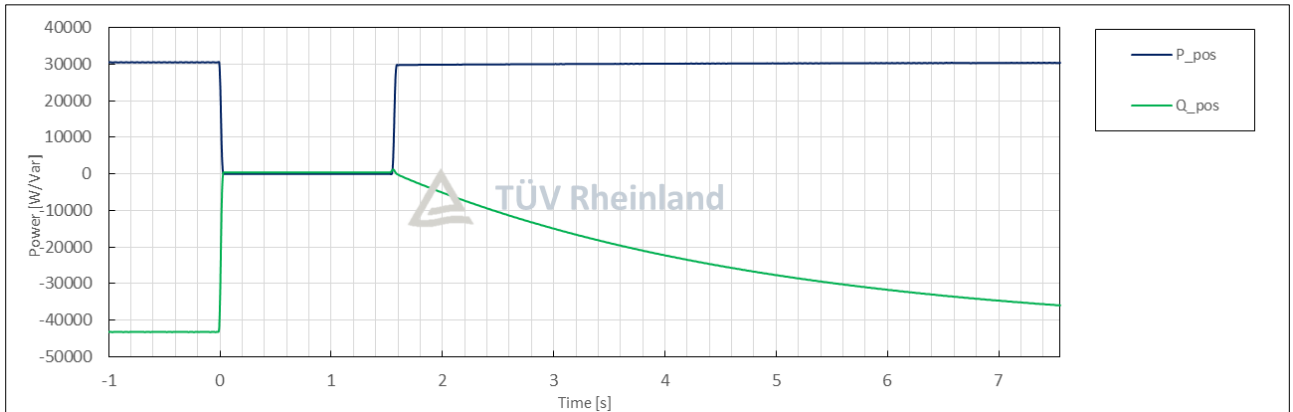

5.8	TABLE: Verification of dynamic network supporting (FVRT)					P
Condition						
	No.	Parameter	Phase ref.	Time ref.	unit	Measurement
General Info.	0	Test number	--	--	--	3.3
	1	Date	--	--	dd.mm.yyyy	28.07.2025
	2	Time (start of test)	--	--	hh:mm:ss.f	13:50:41
	3	Fault type (phase)	--	--		2-phase fault
	4	Setting voltage depth	Line to line	--	p.u.	0.50
	5	Setting dip duration		--		1551
	6	Point of fault entry	Total	--	ms	0
	7	Point of fault clearance	Total	--	ms	1551
	8	Fault duration in empty load test	Total	--	ms	1551
	9	Voltage depth/height in empty load test	Total	t1+100ms to t2 and t1-10s to t1	p.u.	0.51
10	Pos.		p.u.		0.67	
Before dip <t1	11	Voltage	Line to neutral	t1-100s to t1	p.u.	1.00
	12	Current	Pos.	t1-500ms to t1-100ms	p.u.	1.09
	13	Active power	Total	t1-10s to t1	p.u.	1.00
	14		Pos.			1.00
	15	Reactive power	Total	t1-10s to t1	p.u.	-0.43
	16		Pos.			-0.43
	17	Cos ϕ	--	t1-10s to t1	--	0.917
During dip t1 to t2	18	Voltage	Line to neutral	t1+100ms to t2-20ms	p.u.	0.50
	19	Line current	Phase 1	t1+60ms	p.u.	0.01
	20		Phase 2			0.01
	21		Phase 3			0.01
	22	Line current	Phase 1	t1+100ms	p.u.	0.01
	23		Phase 2			0.01
	24		Phase 3			0.01
	25	Active power	Total	t1+100ms to t2-20ms	p.u.	0.00
26	Pos.		0.00			
After dip > t2	27	Voltage	Line to neutral	t2+3s to t2+10s	p.u.	1.00
	28	Active power	Total	t2+3s to t2+10s	p.u.	1.00
	29		Pos.			1.00
	30	Active power rising time	Pos.	--	s	0.055
	31	Reactive power	Total	t2+3s to t2+10s	p.u.	-0.36
	32		Pos.			-0.36
	33	Reactive power rising time	Pos.	--	s	10.027
	34	PGU does not disconnect from grid till 60s after fault	--	t2 to t2+60s	Yes / No	No

Test No. 3.3 idle test

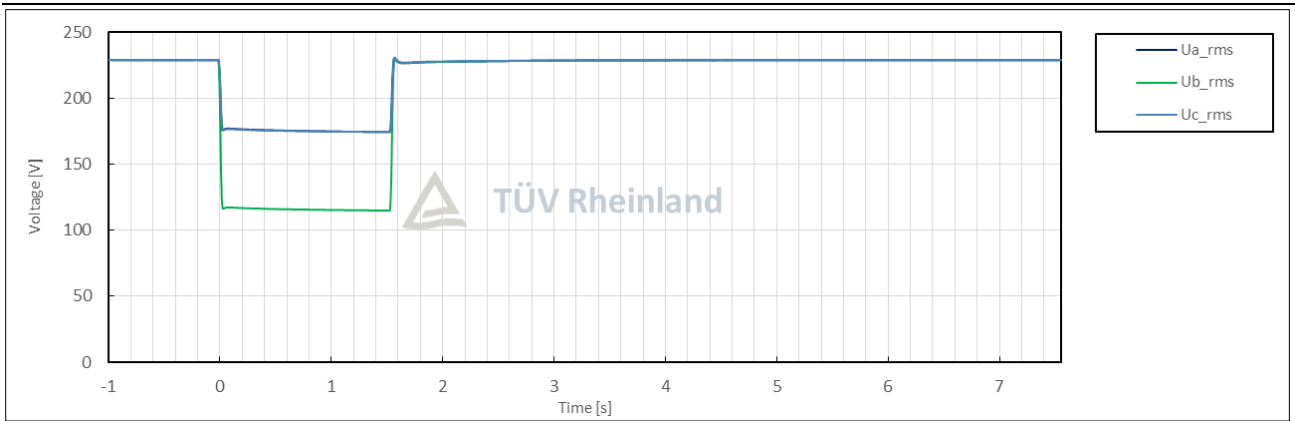
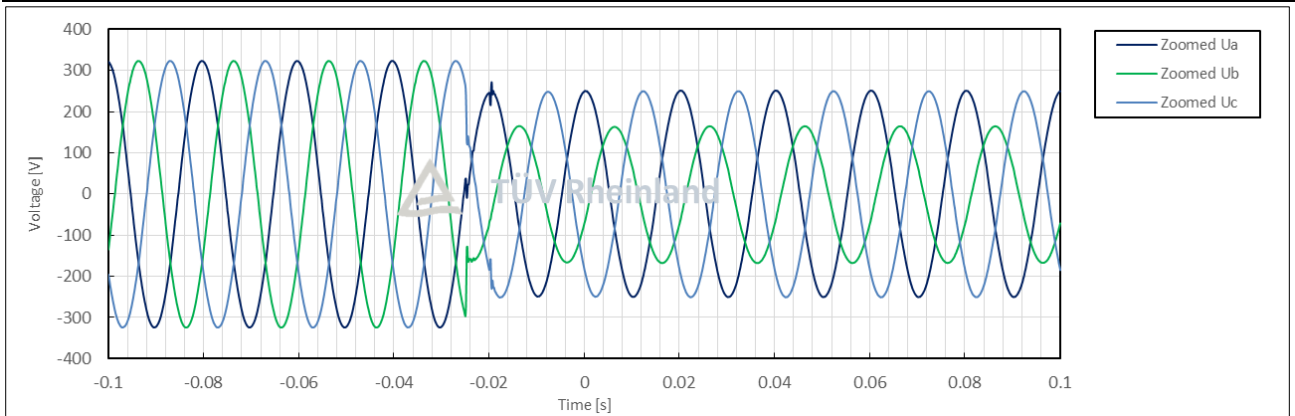
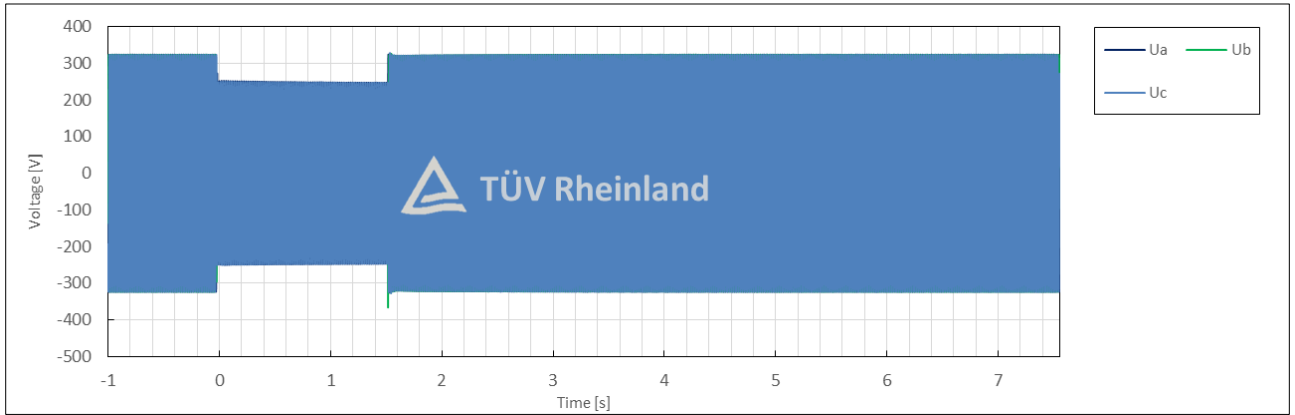

Test No. 3.3 with PGU

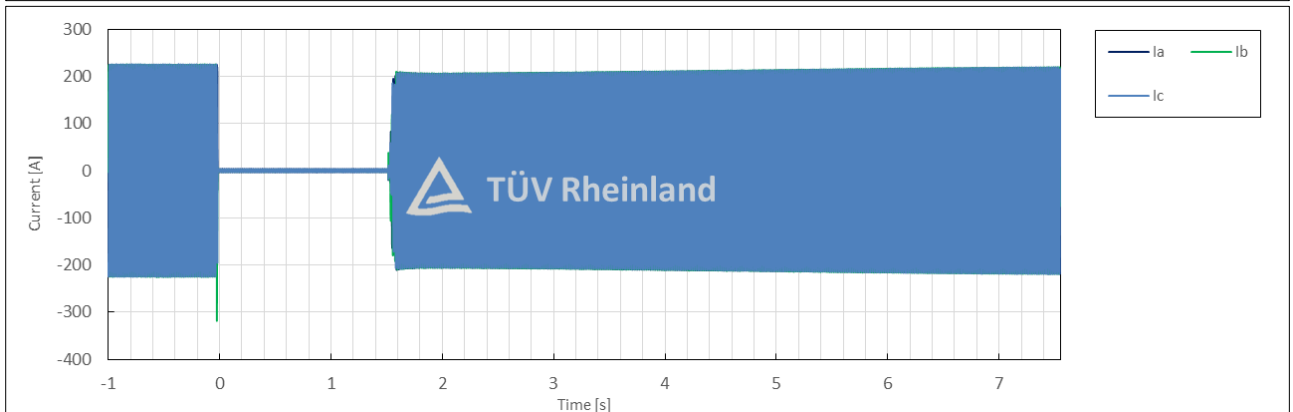
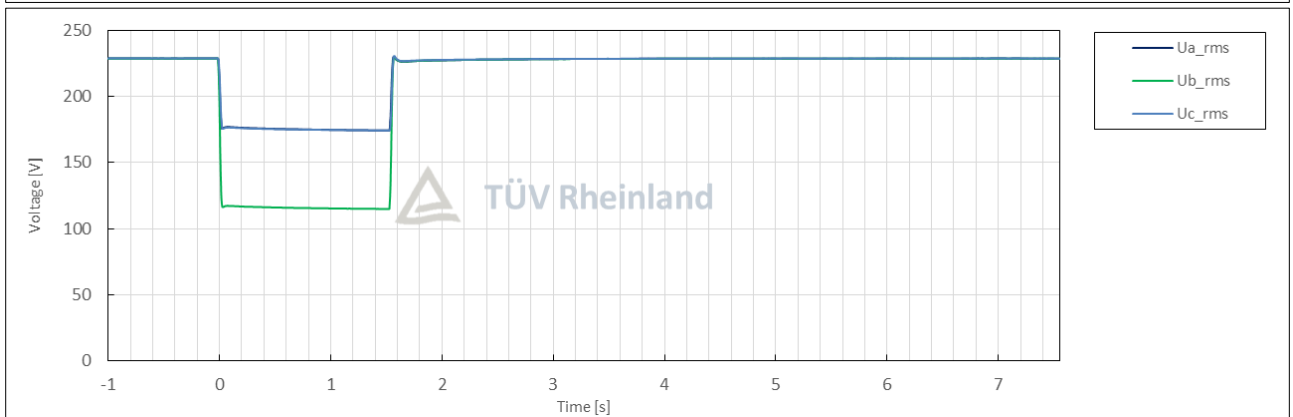
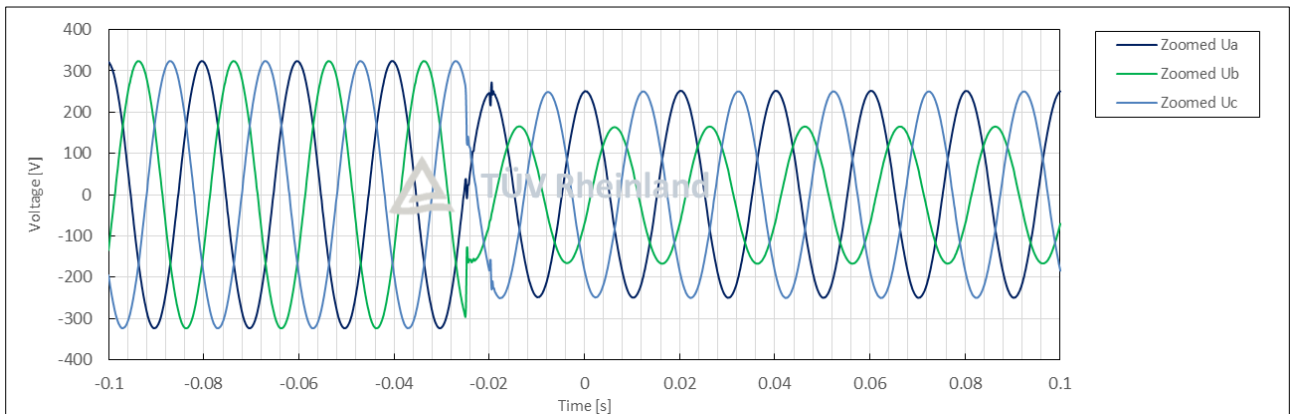
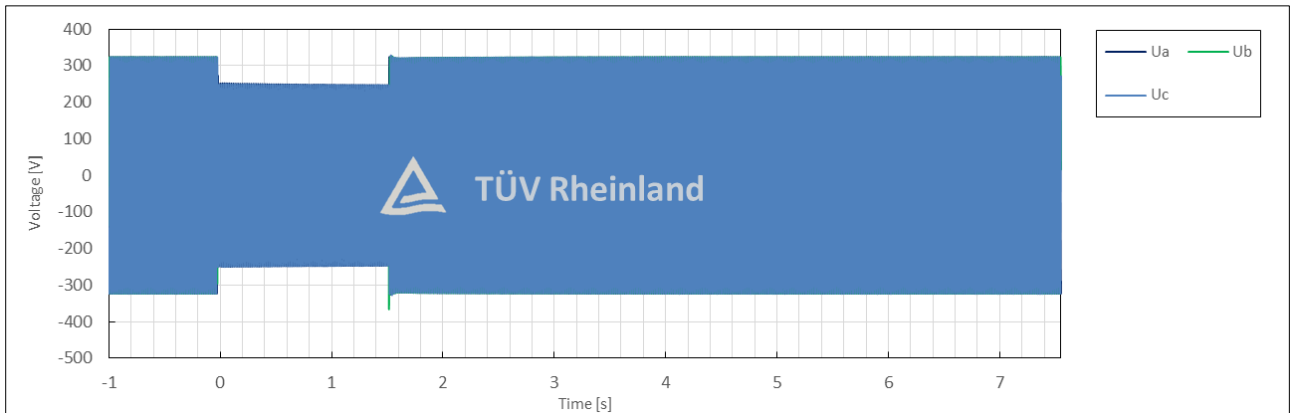

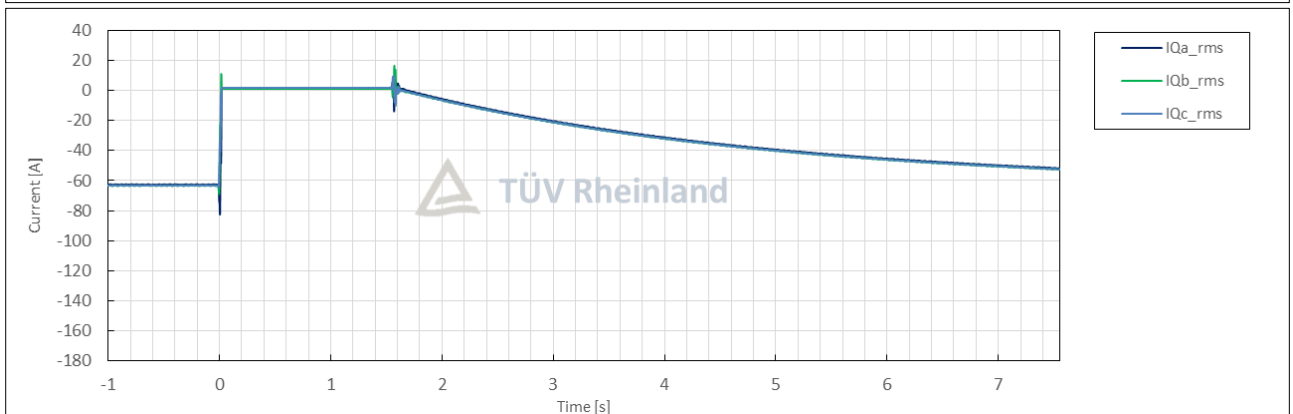
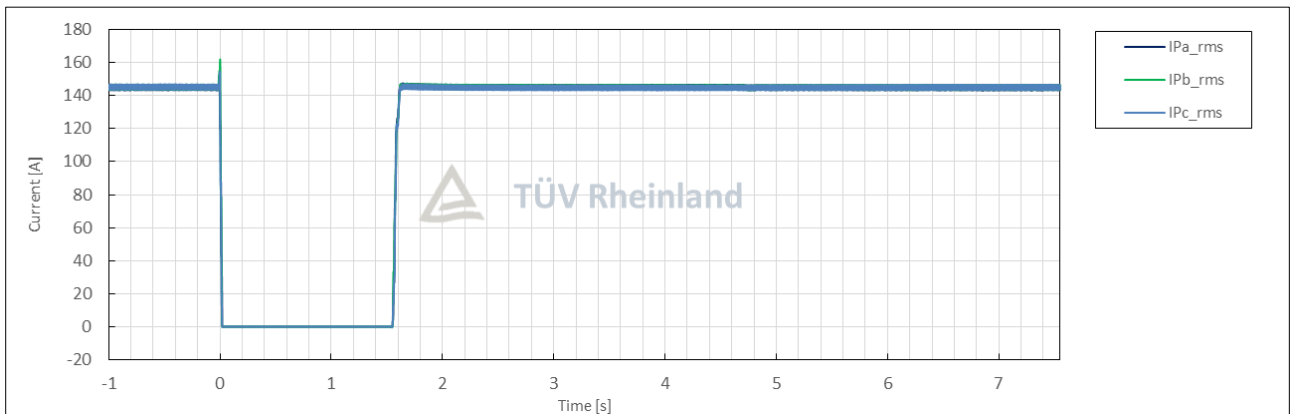
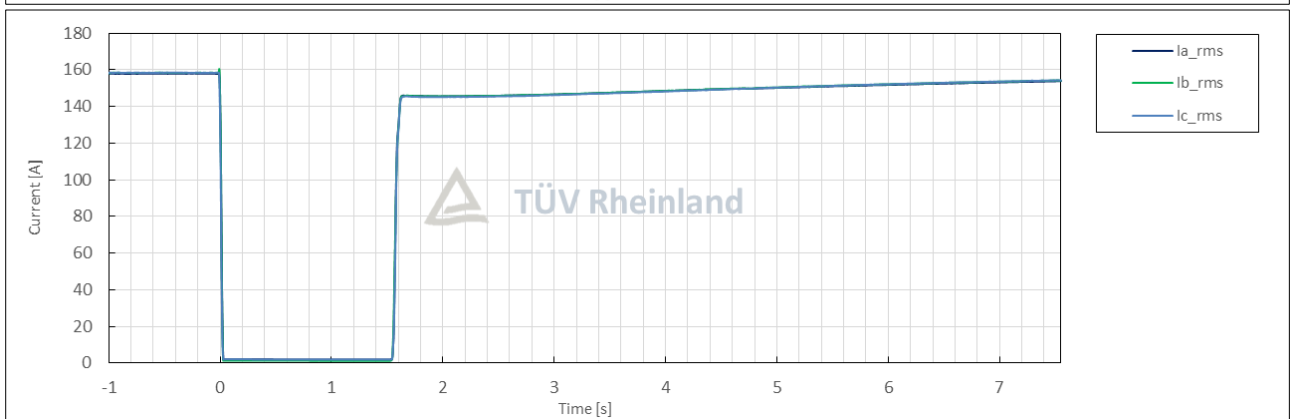
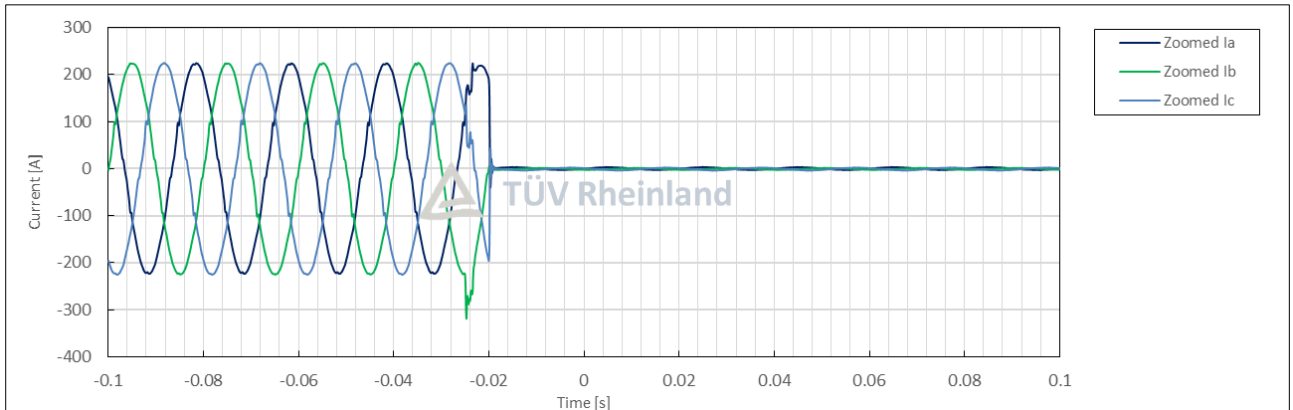

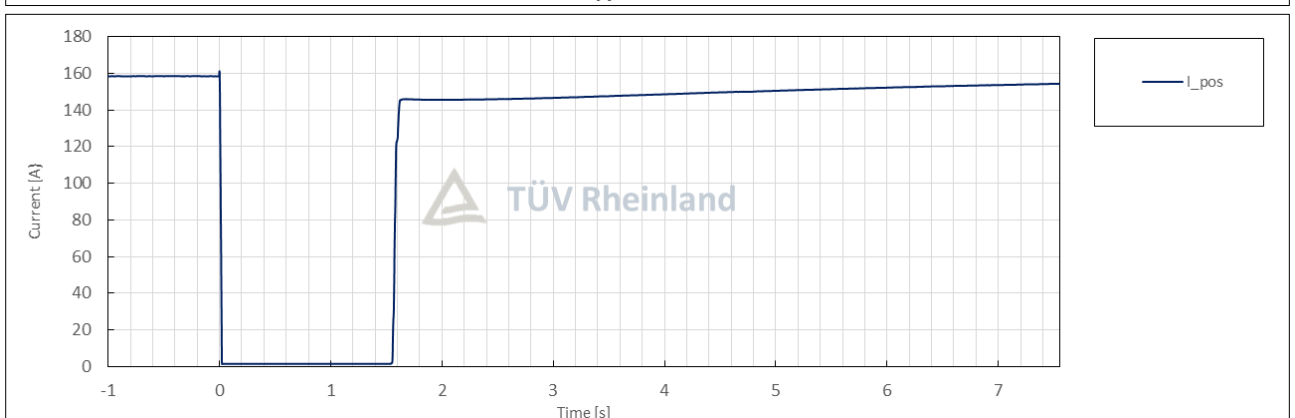
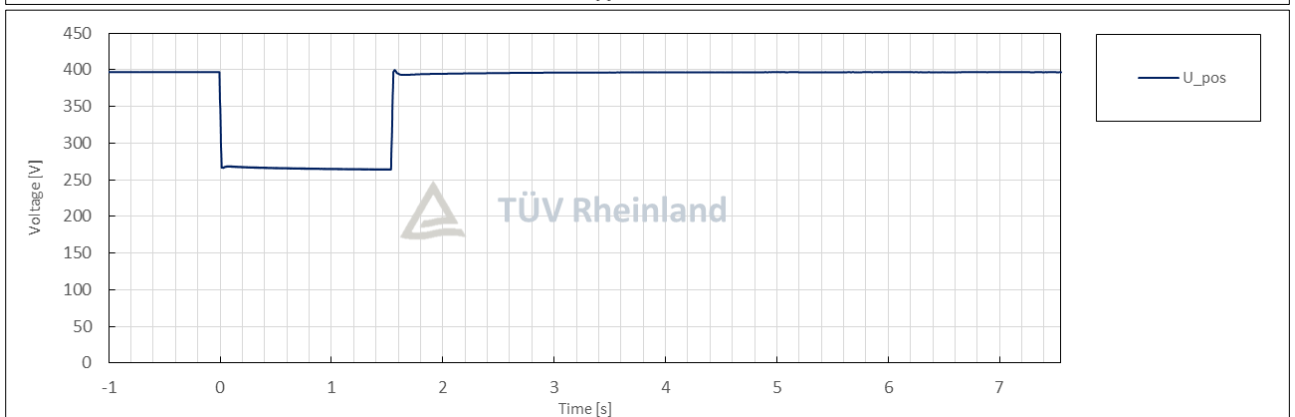
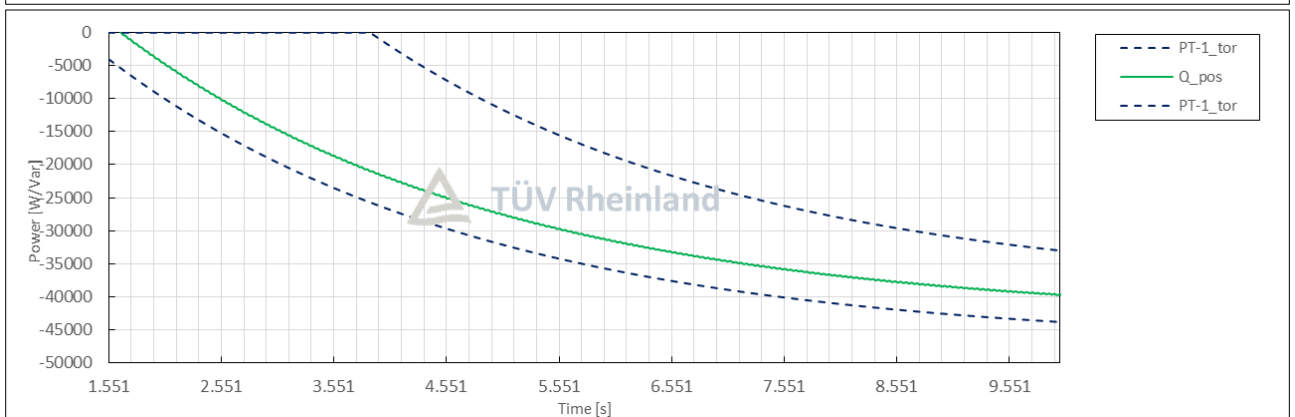
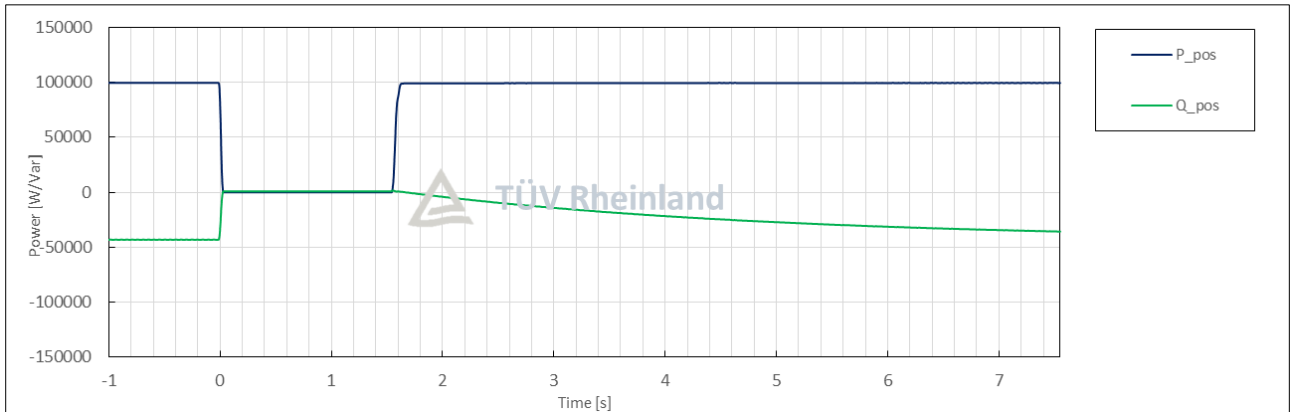

Condition						Measurement
No.	Parameter	Phase ref.	Time ref.	unit		
General Info.	0	Test number	--	--	--	3.4
	1	Date	--	--	dd.mm.yyyy	28.07.2025
	2	Time (start of test)	--	--	hh:mm:ss.f	13:50:58
	3	Fault type (phase)	--	--		2-phase fault
	4	Setting voltage depth	Line to line	--	p.u.	0.50
	5	Setting dip duration		--		1551
	6	Point of fault entry	Total	--	ms	0
	7	Point of fault clearance	Total	--	ms	1551
	8	Fault duration in empty load test	Total	--	ms	1551
	9	Voltage depth/height in empty load test	Total	t1+100ms to t2 and t1-10s to t1	p.u.	0.51
10	Pos.		p.u.		0.67	
Before dip <t1	11	Voltage	Line to neutral	t1-100s to t1	p.u.	0.99
	12	Current	Pos.	t1-500ms to t1-100ms	p.u.	0.53
	13	Active power	Total	t1-10s to t1	p.u.	0.31
	14		Pos.			0.31
	15	Reactive power	Total	t1-10s to t1	p.u.	-0.43
	16		Pos.			-0.43
17	Cos ϕ	--	t1-10s to t1	--	0.577	
During dip t1 to t2	18	Voltage	Line to neutral	t1+100ms to t2-20ms	p.u.	0.50
	19	Line current	Phase 1	t1+60ms	p.u.	0.01
	20		Phase 2			0.01
	21		Phase 3			0.01
	22	Line current	Phase 1	t1+100ms	p.u.	0.01
	23		Phase 2			0.01
	24		Phase 3			0.01
	25	Active power	Total	t1+100ms to t2-20ms	p.u.	0.00
26	Pos.		0.00			
After dip > t2	27	Voltage	Line to neutral	t2+3s to t2+10s	p.u.	0.99
	28	Active power	Total	t2+3s to t2+10s	p.u.	0.30
	29		Pos.			0.30
	39	Active power rising time	Pos.	--	s	0.03
	31	Reactive power	Total	t2+3s to t2+10s	p.u.	-0.36
	32		Pos.			-0.36
	33	Reactive power rising time	Pos.	--	s	9.978
34	PGU does not disconnect from grid till 60s after fault	--	t2 to t2+60s	Yes / No	No	

Test No. 3.4 idle test

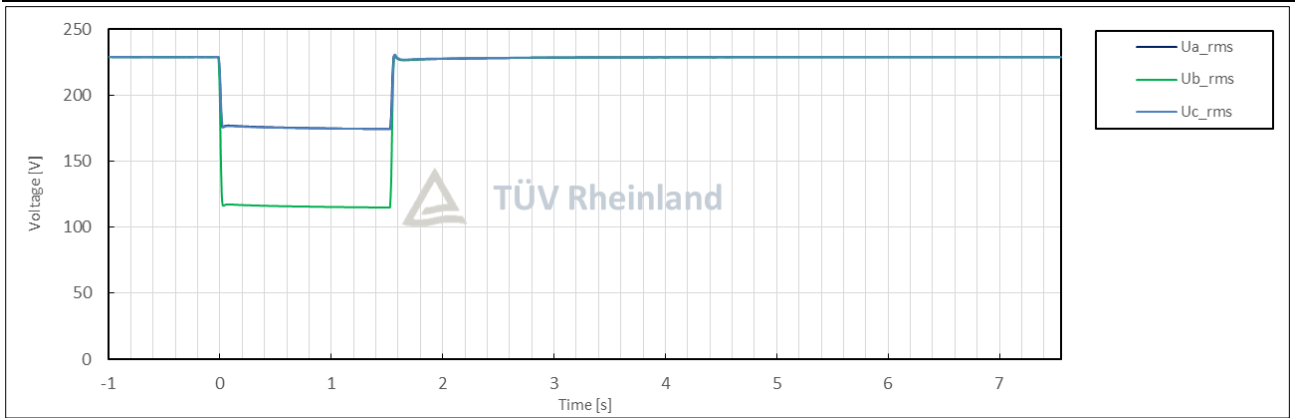
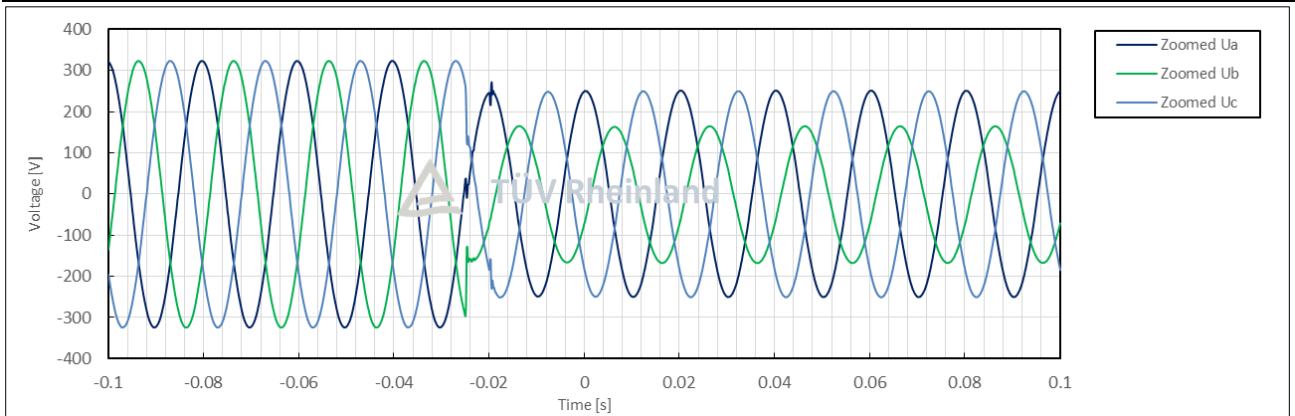
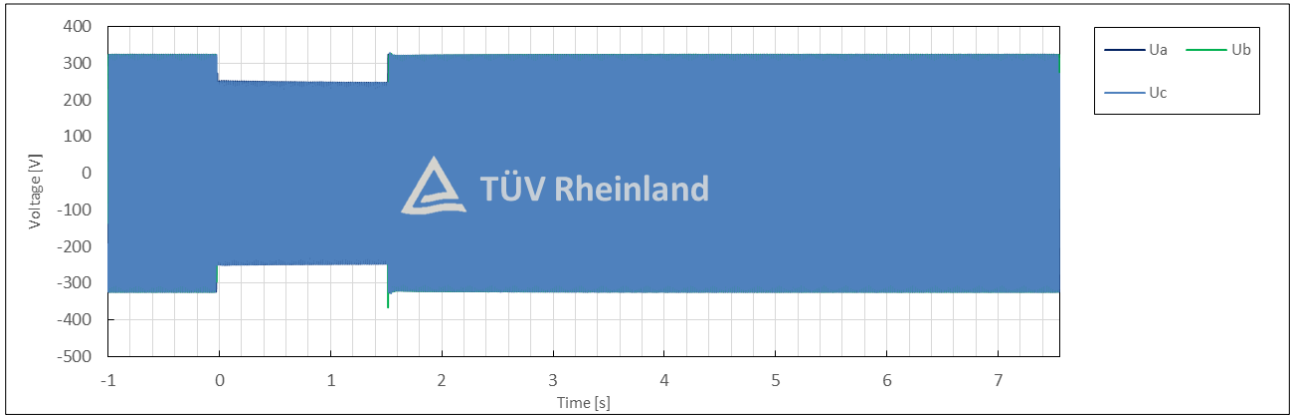

Test No. 3.4 with PGU

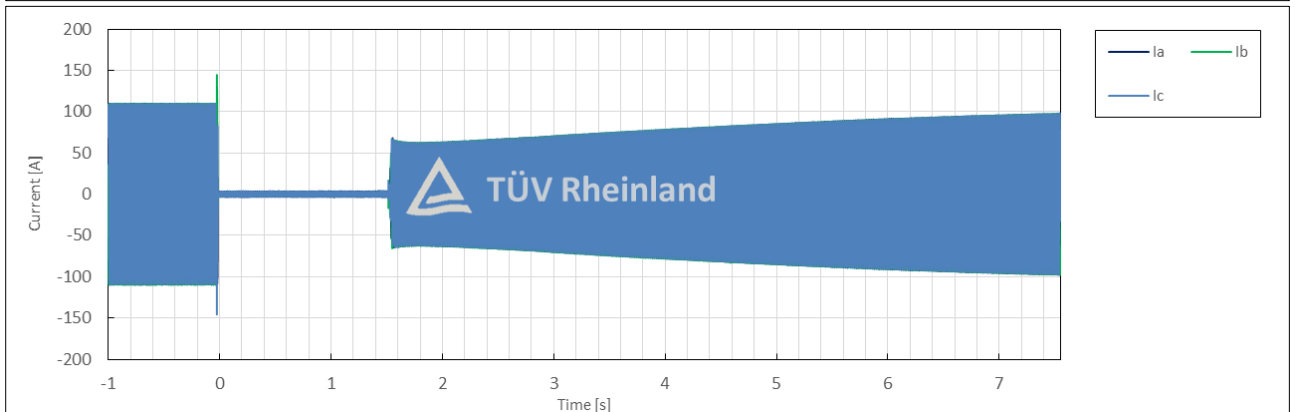
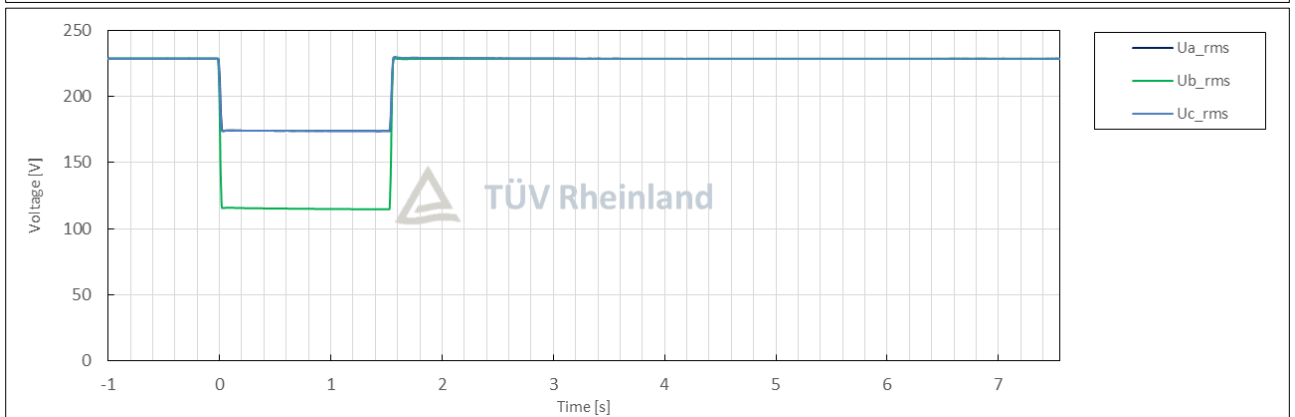
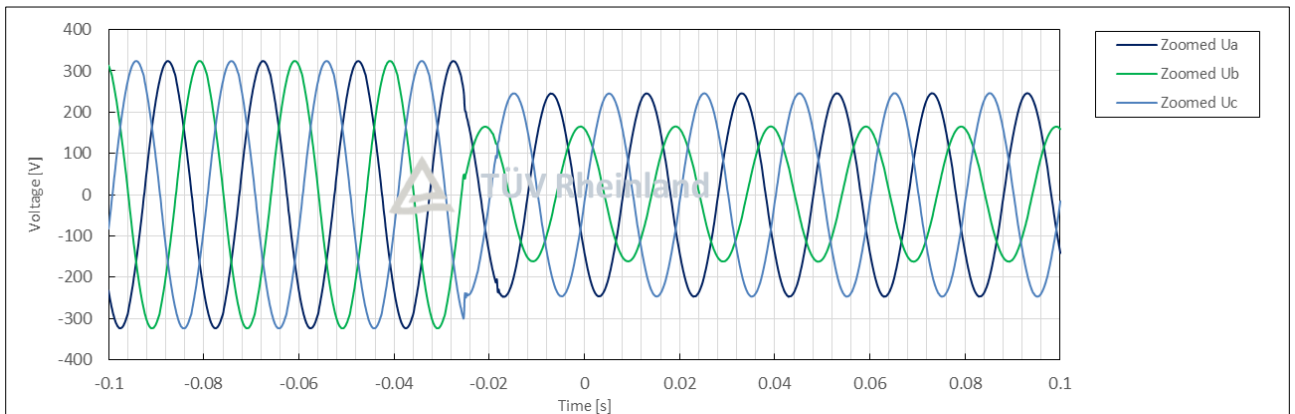
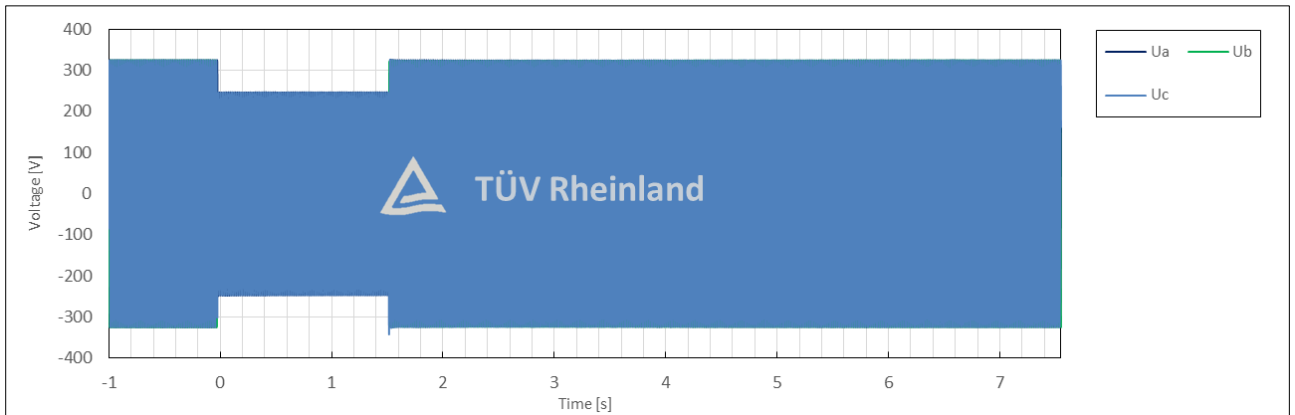

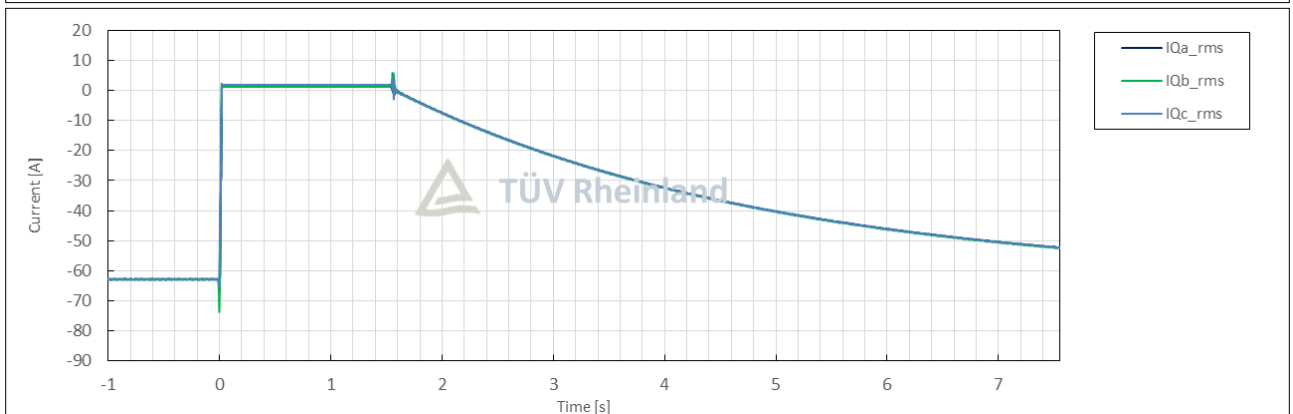
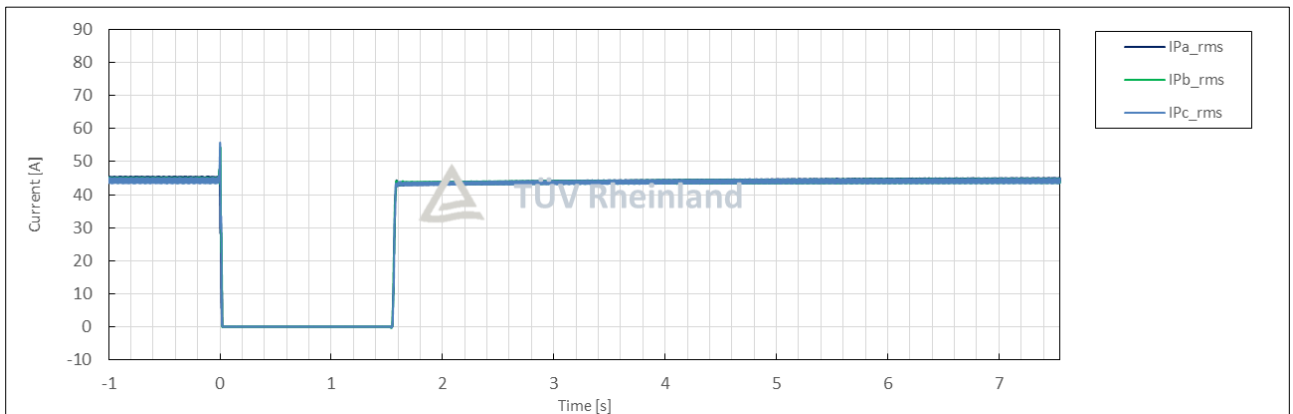
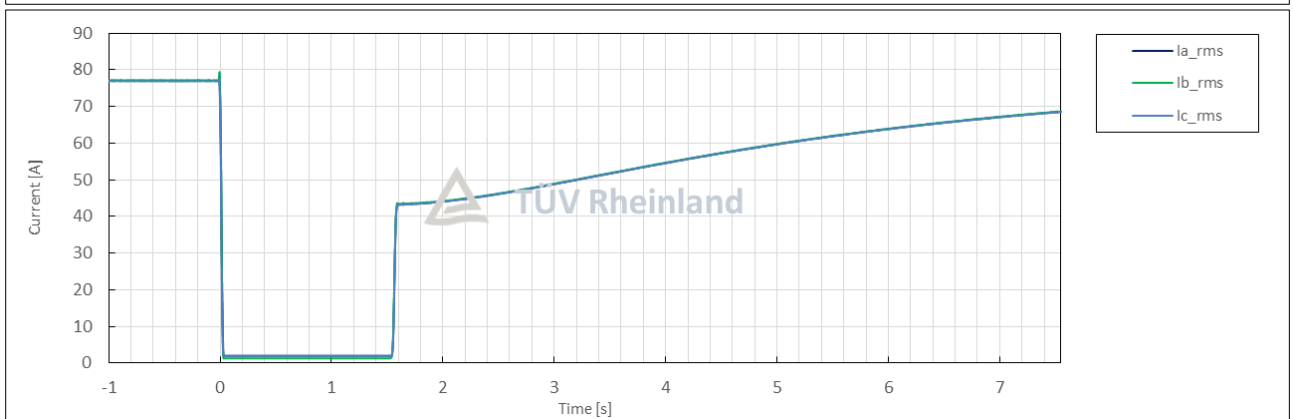
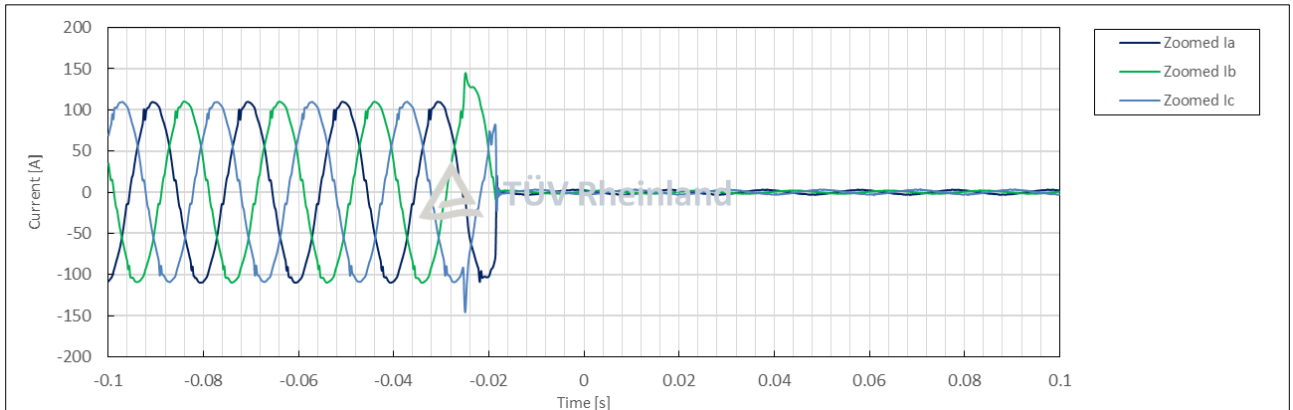

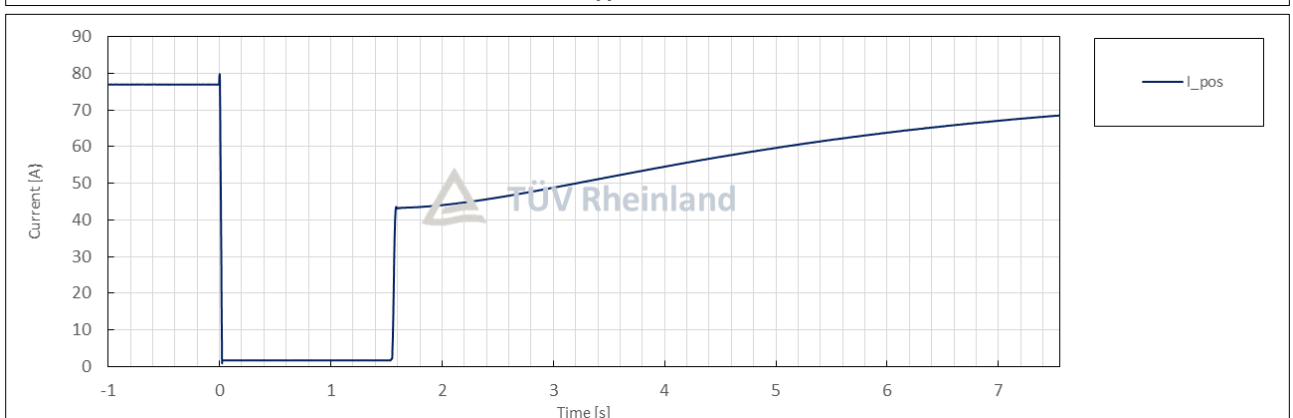
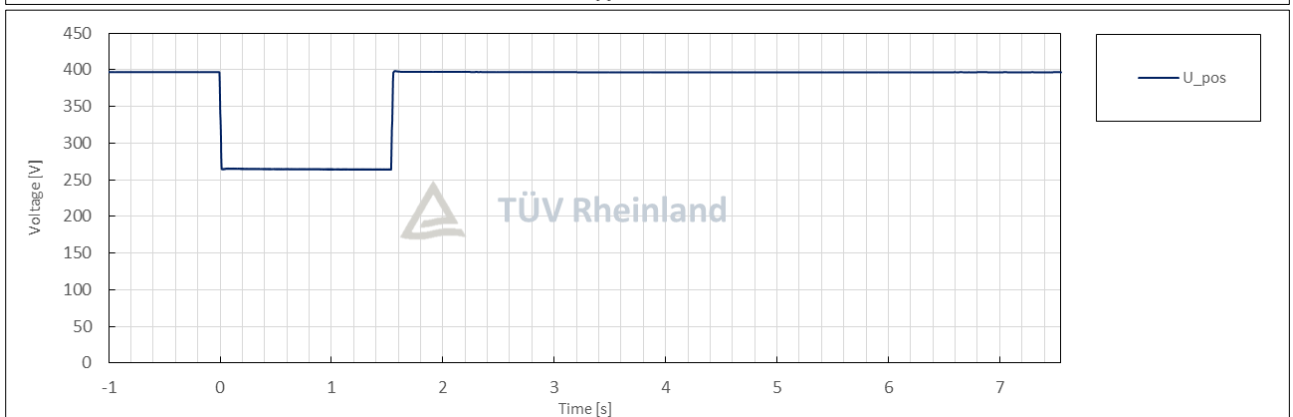
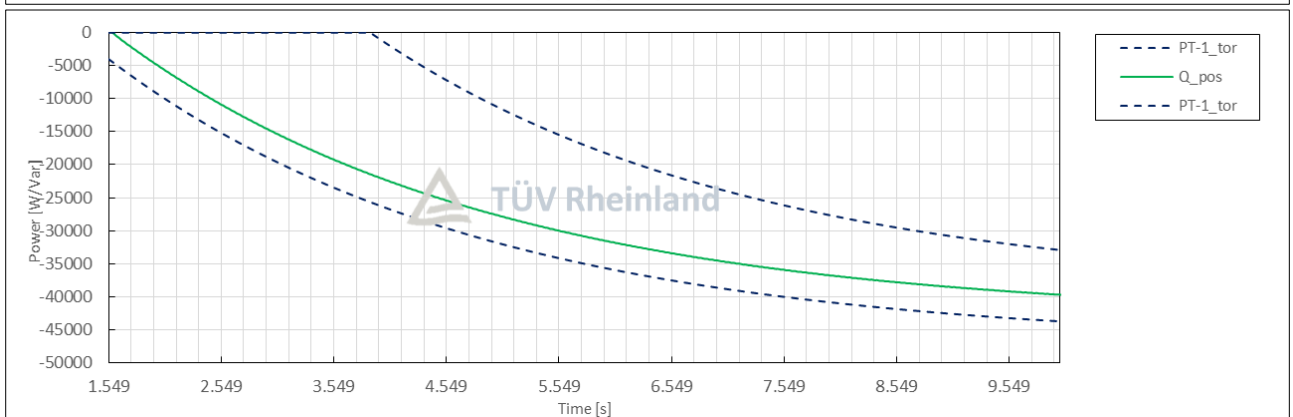
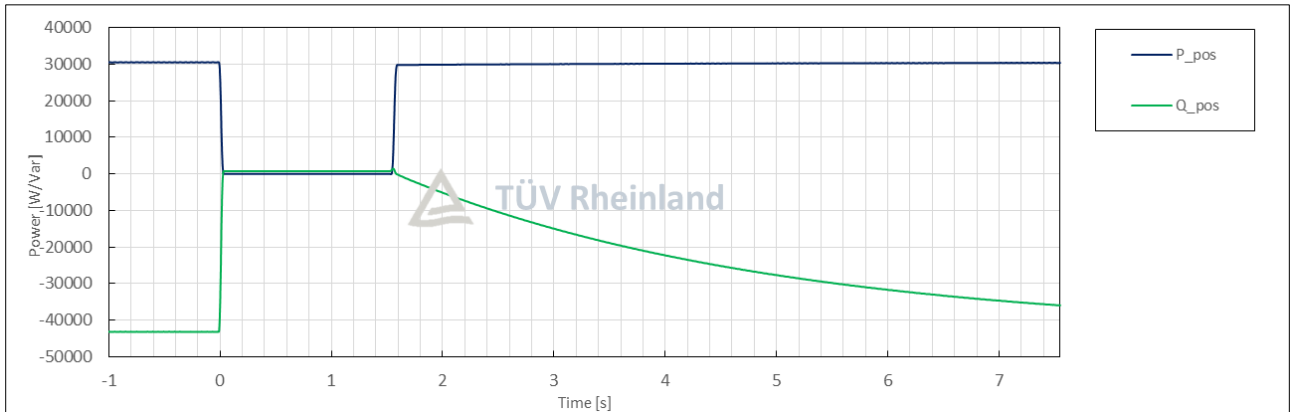

Condition						Measurement
No.	Parameter	Phase ref.	Time ref.	unit		
General Info.	0	Test number	--	--	--	4.1
	1	Date	--	--	dd.mm.yyyy	28.07.2025
	2	Time (start of test)	--	--	hh:mm:ss.f	13:52:10
	3	Fault type (phase)	--	--		3-phase fault
	4	Setting voltage depth	Line to line	--	p.u.	0.85
	5	Setting dip duration		--		61022
	6	Point of fault entry	Total	--	ms	0
	7	Point of fault clearance	Total	--	ms	61022
	8	Fault duration in empty load test	Total	--	ms	61022
	9	Voltage depth/height in empty load test	Total	t1+100ms to t2 and t1-10s to t1	p.u.	0.85
10	Pos.		p.u.		0.85	
Before dip <t1	11	Voltage	Line to neutral	t1-100s to t1	p.u.	1.00
	12	Current	Pos.	t1-500ms to t1-100ms	p.u.	0.99
	13	Active power	Total	t1-10s to t1	p.u.	0.99
	14		Pos.			0.99
	15	Reactive power	Total	t1-10s to t1	p.u.	0.01
	16		Pos.			0.01
17	Cos ϕ	--	t1-10s to t1	--	1.000	
During dip t1 to t2	18	Voltage	Line to neutral	t1+100ms to t2-20ms	p.u.	0.85
	19	Line current	Phase 1	t1+60ms	p.u.	1.15
	20		Phase 2			1.15
	21		Phase 3			1.16
	22	Line current	Phase 1	t1+100ms	p.u.	1.14
	23		Phase 2			1.15
	24		Phase 3			1.15
	25	Active power	Total	t1+100ms to t2-20ms	p.u.	0.97
26	Pos.		0.97			
After dip > t2	27	Voltage	Line to neutral	t2+3s to t2+10s	p.u.	1.00
	28	Active power	Total	t2+3s to t2+10s	p.u.	0.99
	29		Pos.			0.99
	39	Active power rising time	Pos.	--	s	N/A
	31	Reactive power	Total	t2+3s to t2+10s	p.u.	0.01
	32		Pos.			0.01
	33	Reactive power rising time	Pos.	--	s	N/A
34	PGU does not disconnect from grid till 60s after fault	--	t2 to t2+60s	Yes / No	No	

Test No. 4.1 idle test

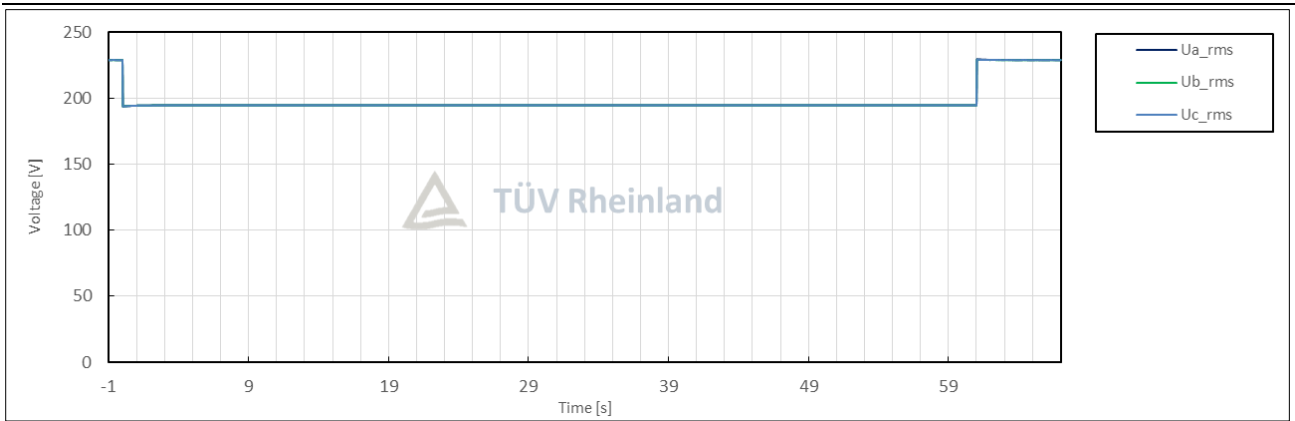
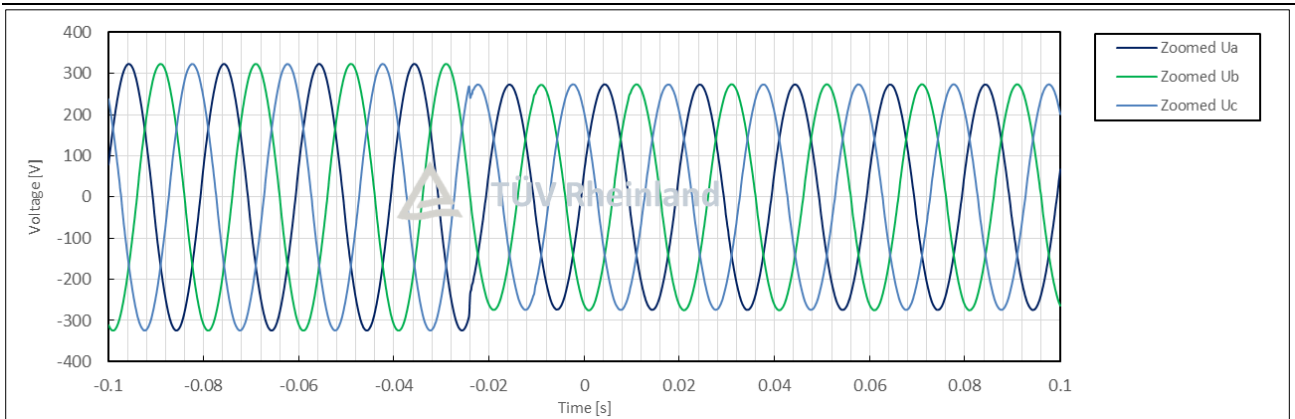
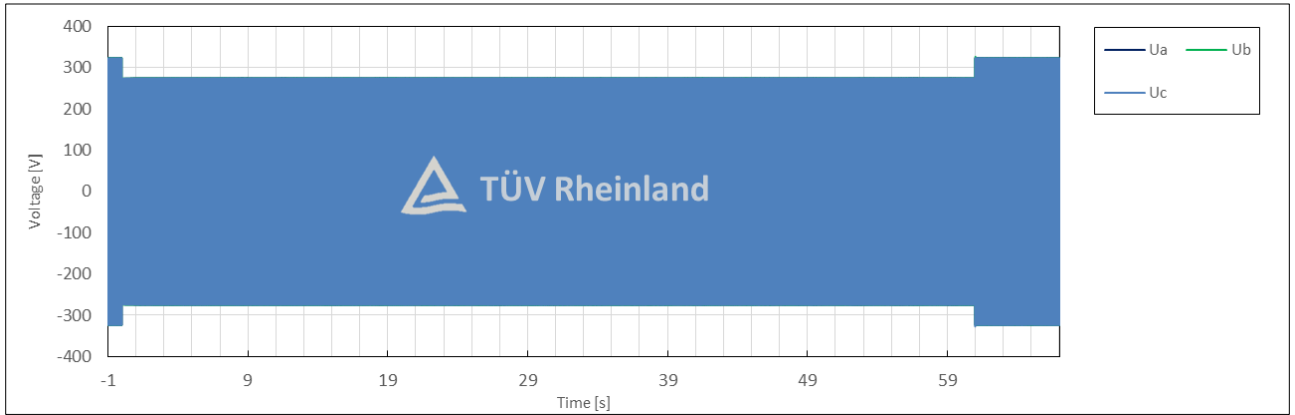

Test No. 4.1 with PGU

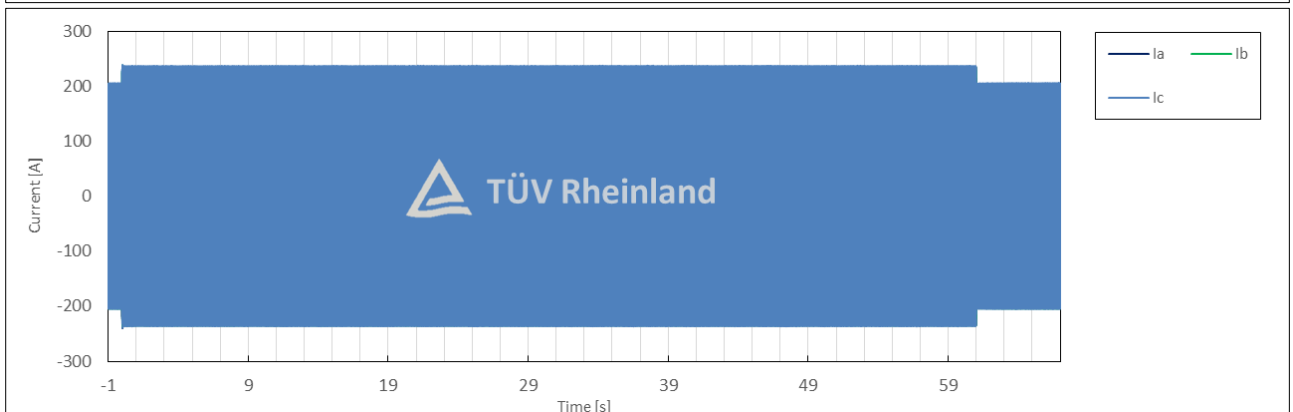
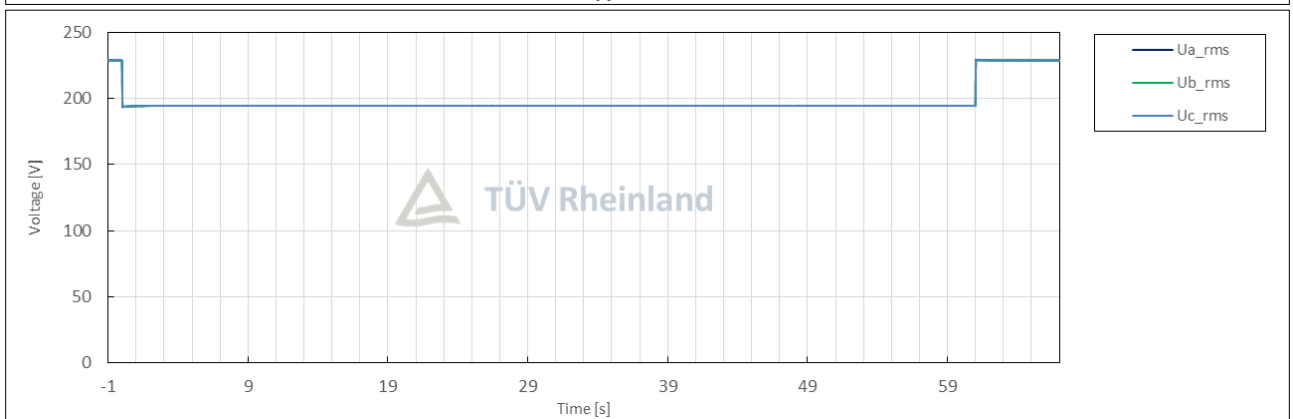
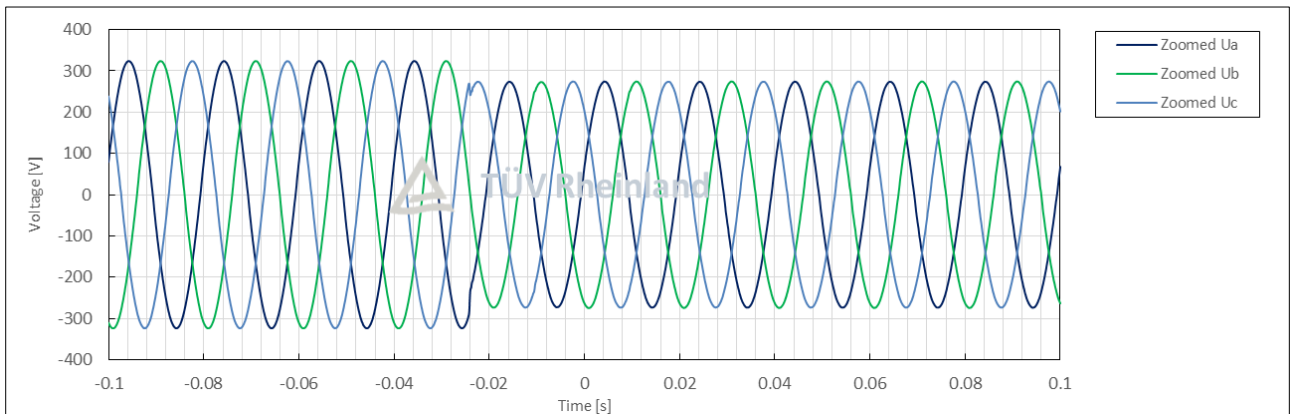
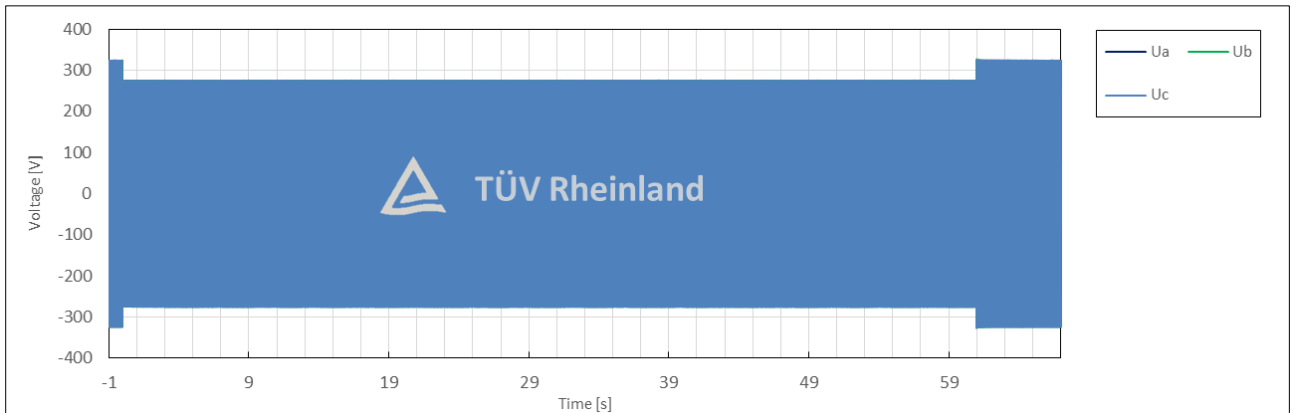

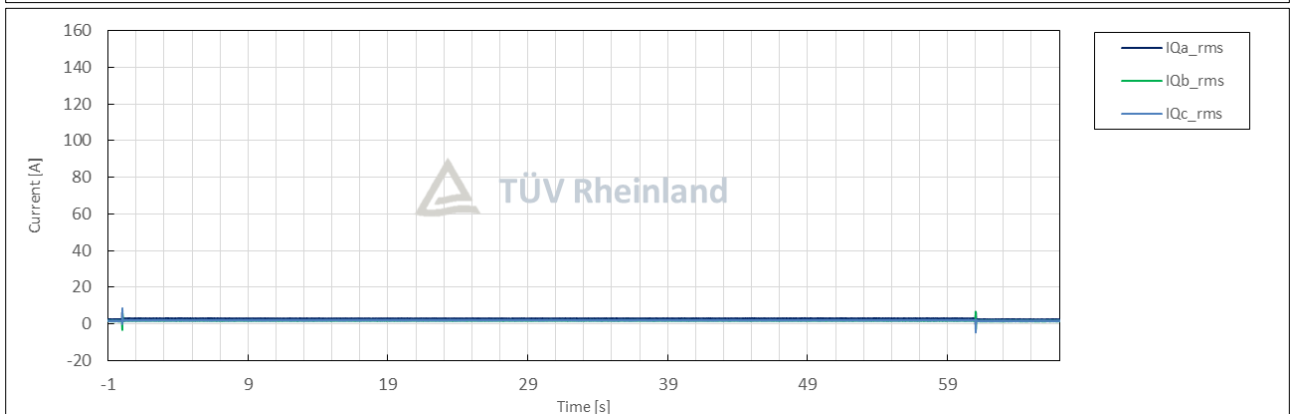
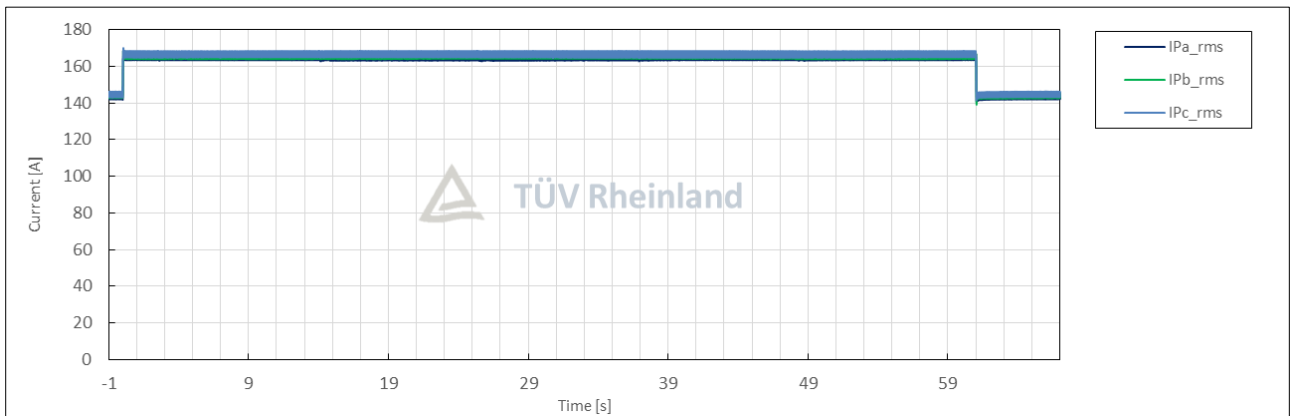
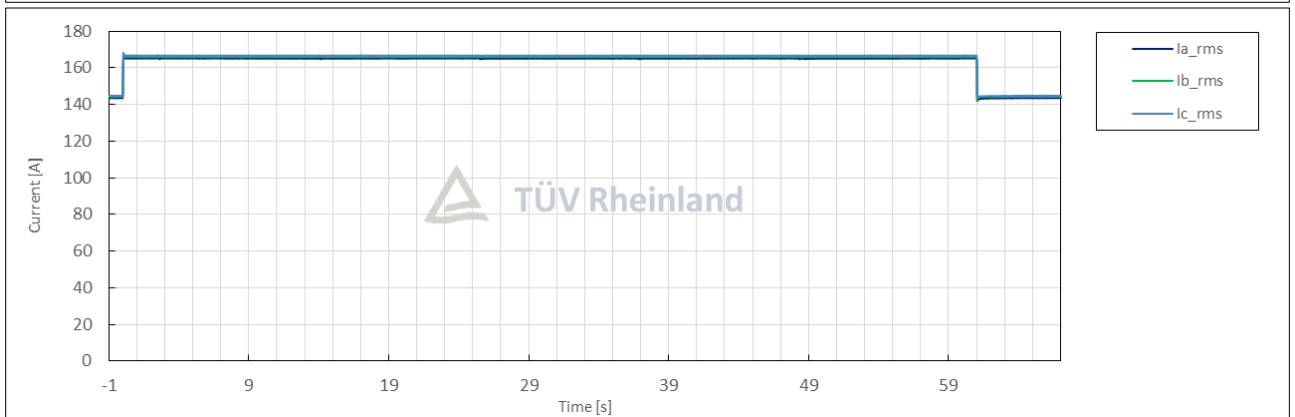
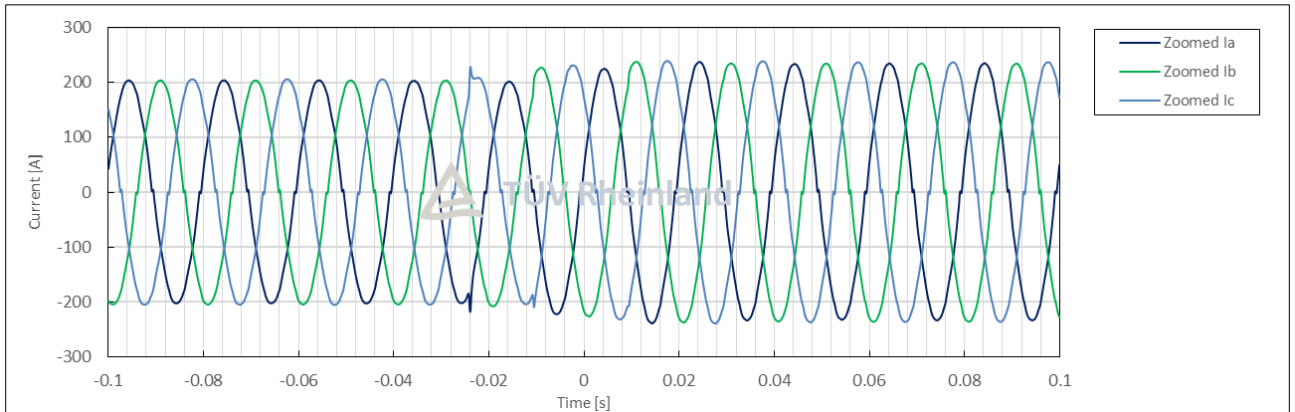

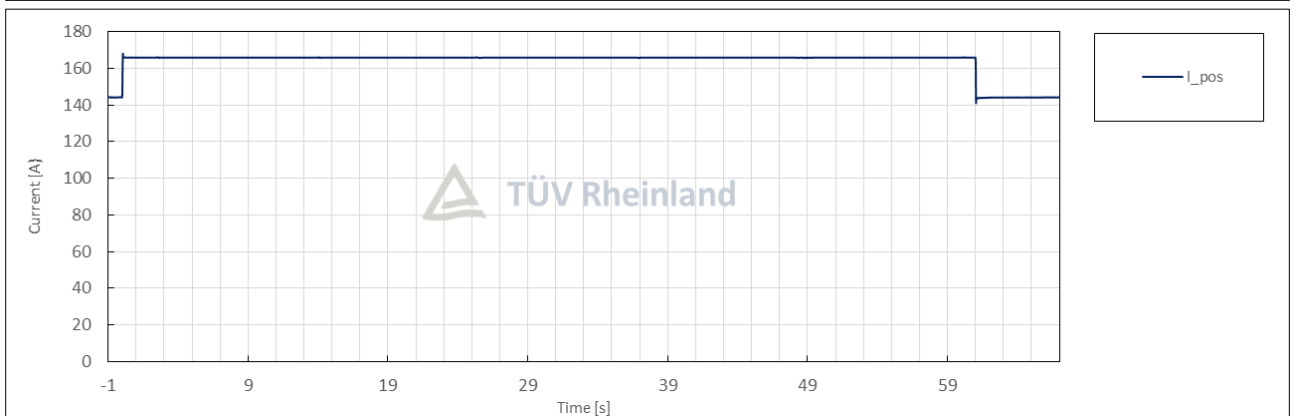
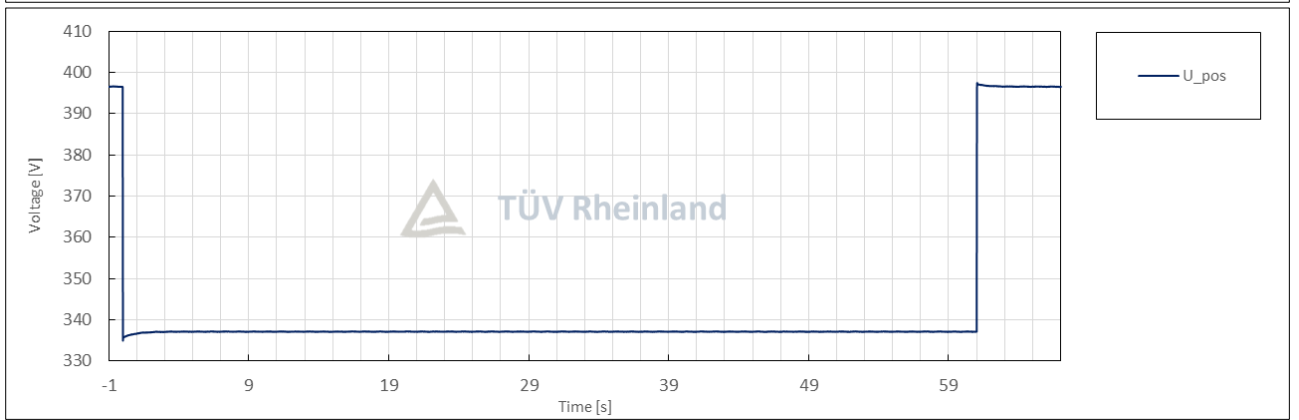
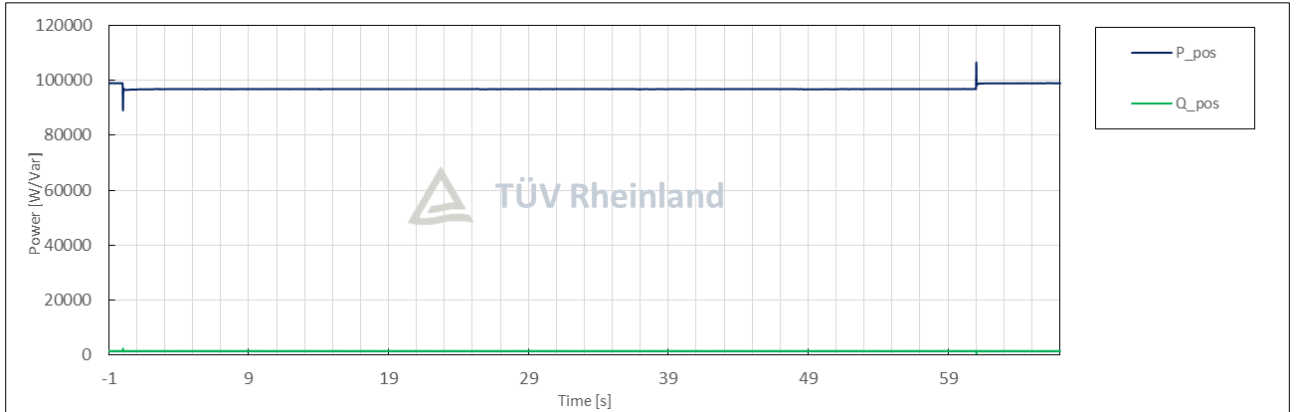

Condition						Measurement
No.	Parameter	Phase ref.	Time ref.	unit		
General Info.	0	Test number	--	--	--	4.2
	1	Date	--	--	dd.mm.yyyy	28.07.2025
	2	Time (start of test)	--	--	hh:mm:ss.f	13:52:06
	3	Fault type (phase)	--	--		3-phase fault
	4	Setting voltage depth	Line to line	--	p.u.	0.85
	5	Setting dip duration		--		61022
	6	Point of fault entry	Total	--	ms	0
	7	Point of fault clearance	Total	--	ms	61022
	8	Fault duration in empty load test	Total	--	ms	61022
	9	Voltage depth/height in empty load test	Total	t1+100ms to t2 and t1-10s to t1	p.u.	0.85
10	Pos.		p.u.		0.85	
Before dip <t1	11	Voltage	Line to neutral	t1-100s to t1	p.u.	0.99
	12	Current	Pos.	t1-500ms to t1-100ms	p.u.	0.30
	13	Active power	Total	t1-10s to t1	p.u.	0.30
	14		Pos.			0.30
	15	Reactive power	Total	t1-10s to t1	p.u.	0.00
	16		Pos.			0.00
17	Cos ϕ	--	t1-10s to t1	--	1.000	
During dip t1 to t2	18	Voltage	Line to neutral	t1+100ms to t2-20ms	p.u.	0.85
	19	Line current	Phase 1	t1+60ms	p.u.	0.35
	20		Phase 2			0.35
	21		Phase 3			0.36
	22	Line current	Phase 1	t1+100ms	p.u.	0.35
	23		Phase 2			0.35
	24		Phase 3			0.35
	25	Active power	Total	t1+100ms to t2-20ms	p.u.	0.30
26	Pos.		0.30			
After dip > t2	27	Voltage	Line to neutral	t2+3s to t2+10s	p.u.	0.99
	28	Active power	Total	t2+3s to t2+10s	p.u.	0.30
	29		Pos.			0.30
	39	Active power rising time	Pos.	--	s	N/A
	31	Reactive power	Total	t2+3s to t2+10s	p.u.	0.00
	32		Pos.			0.00
	33	Reactive power rising time	Pos.	--	s	N/A
34	PGU does not disconnect from grid till 60s after fault	--	t2 to t2+60s	Yes / No	No	

Test No. 4.2 idle test

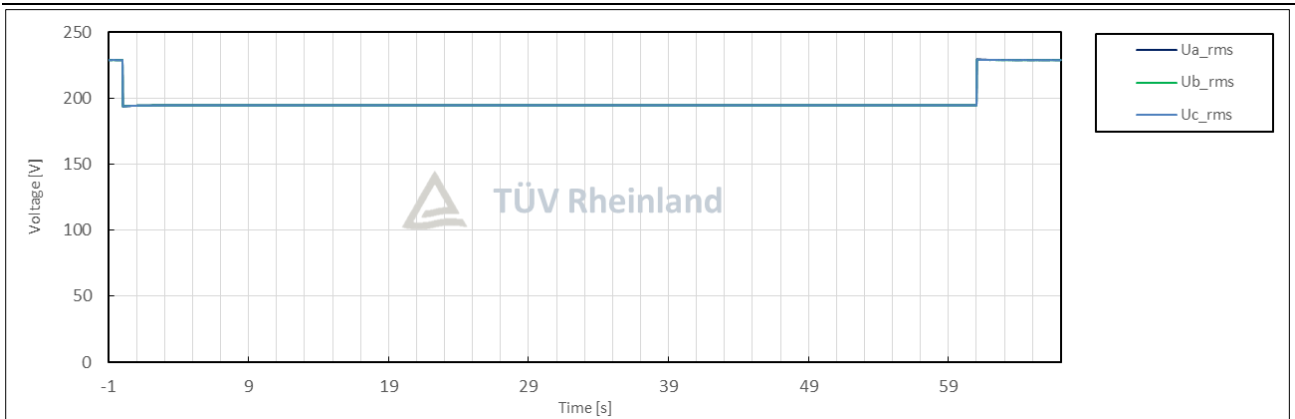
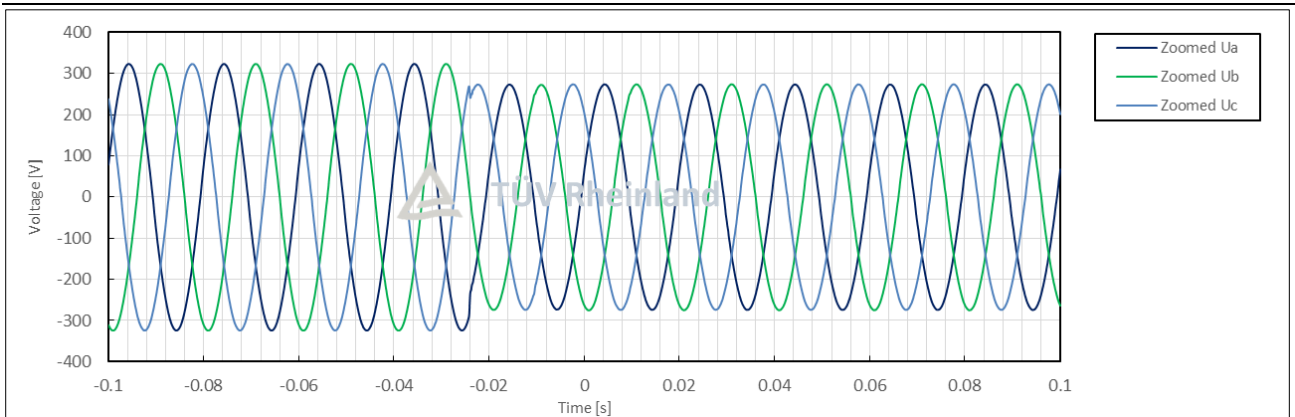
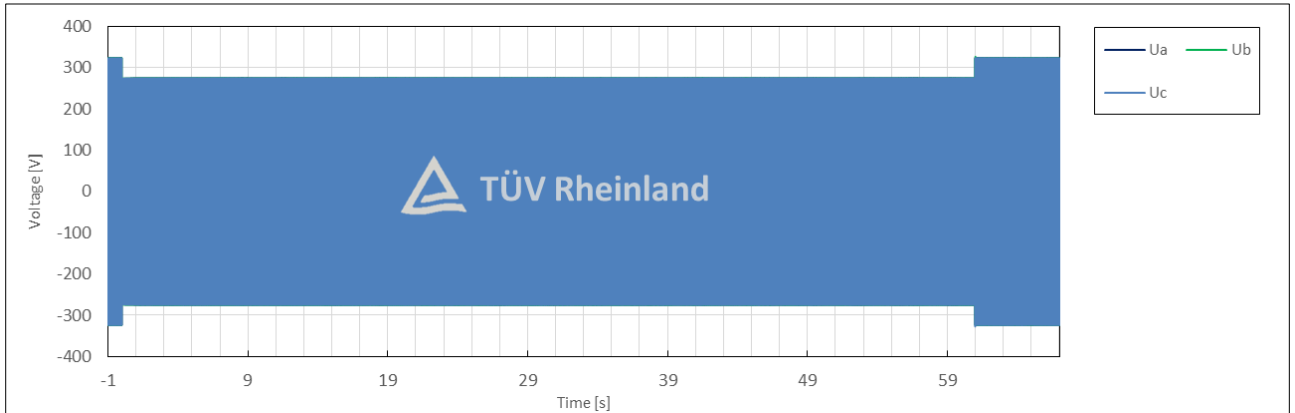

Test No. 4.2 with PGU

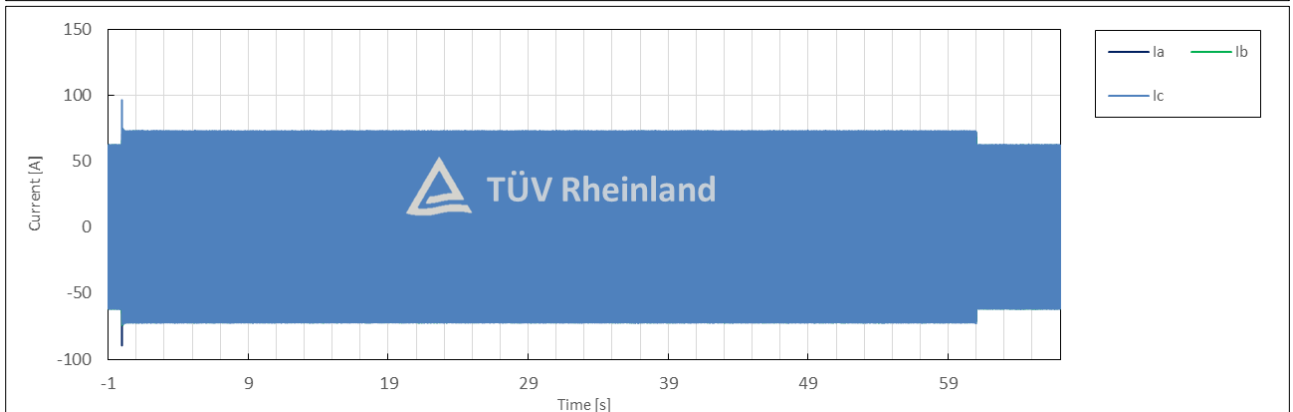
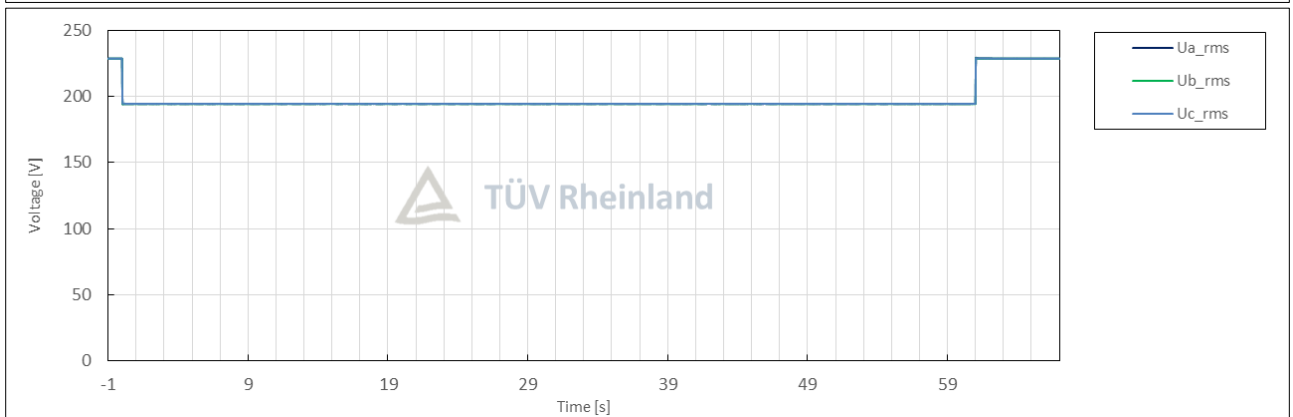
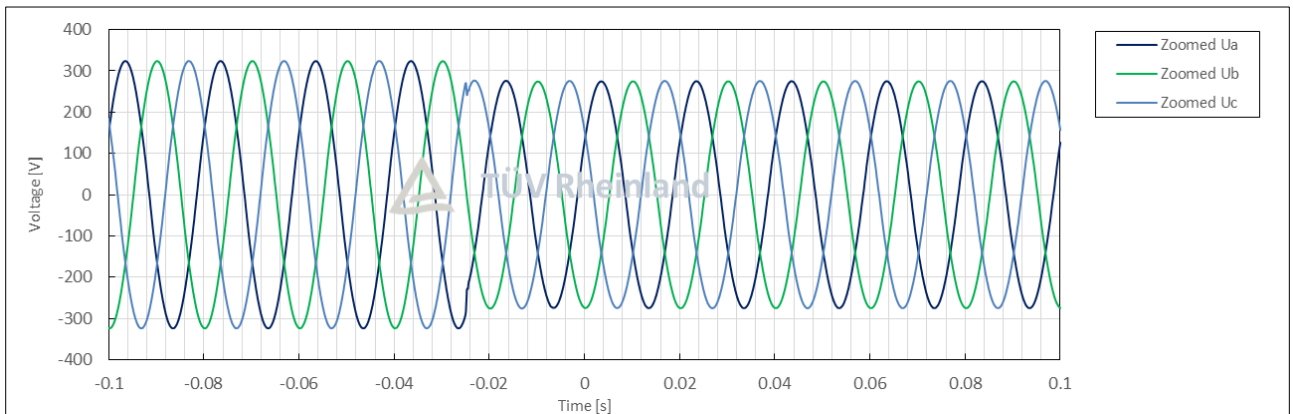
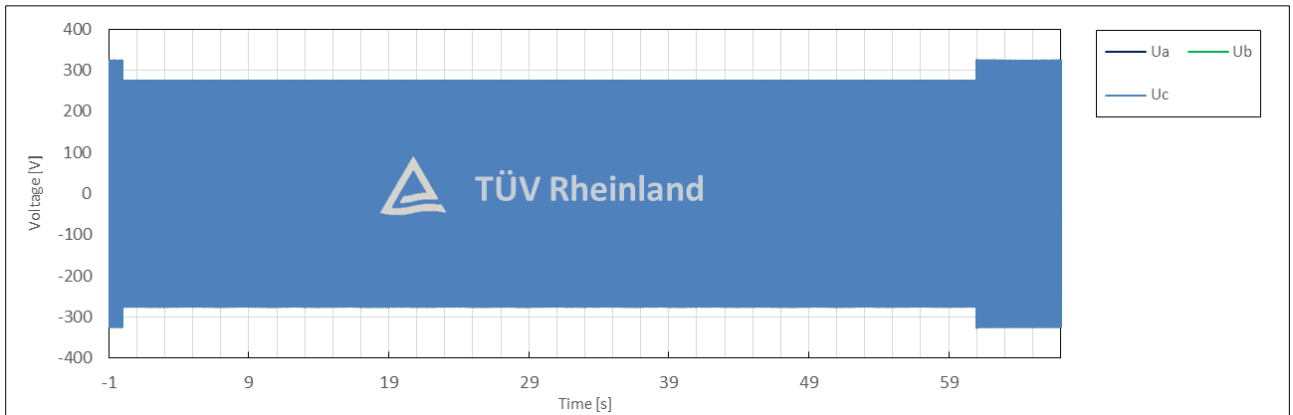

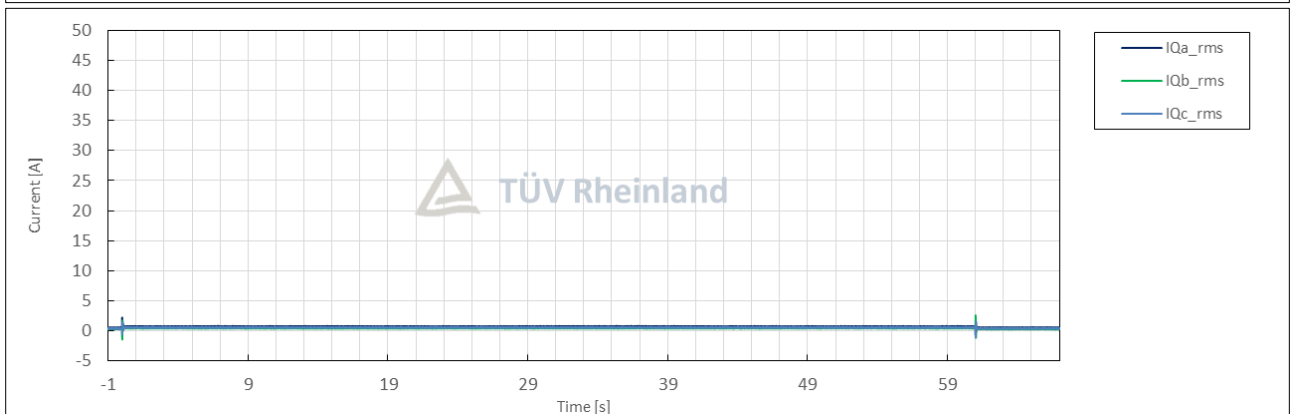
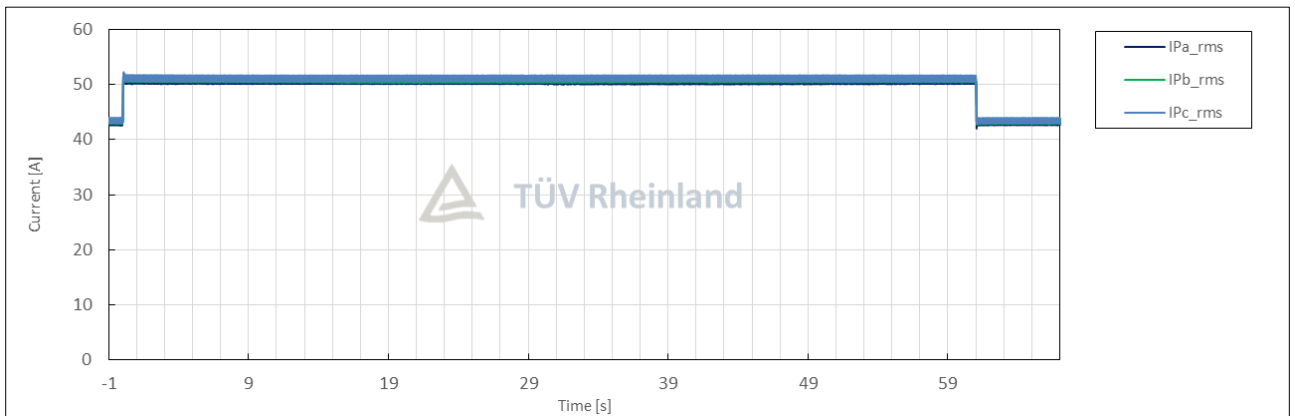
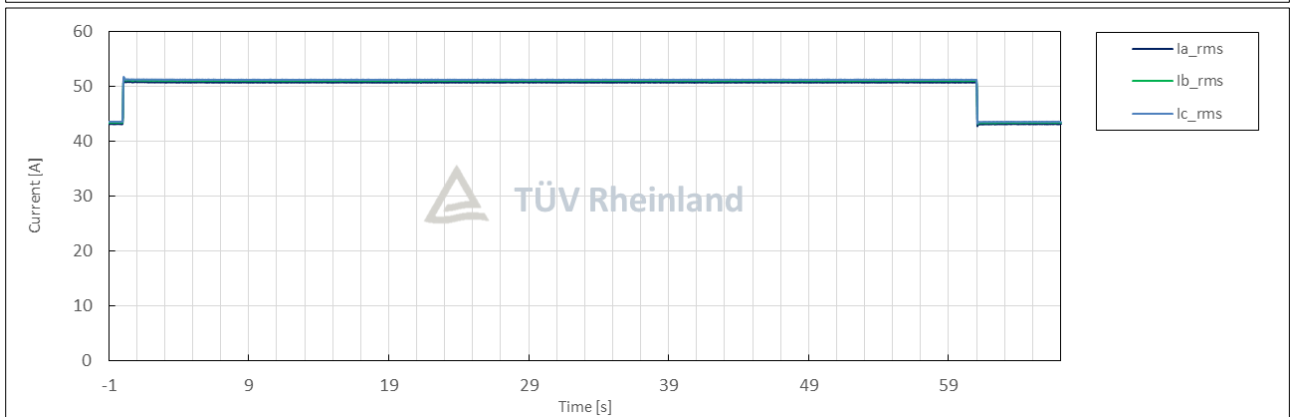
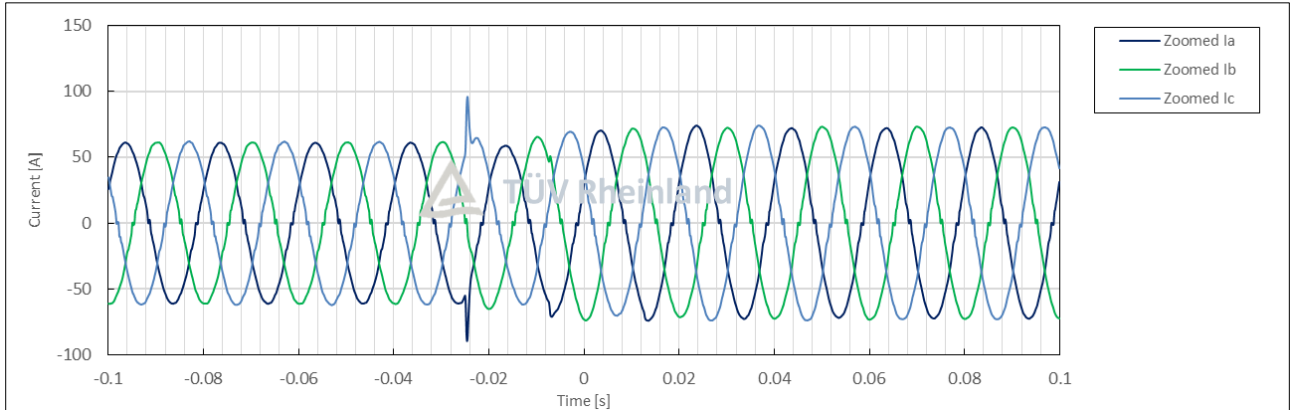

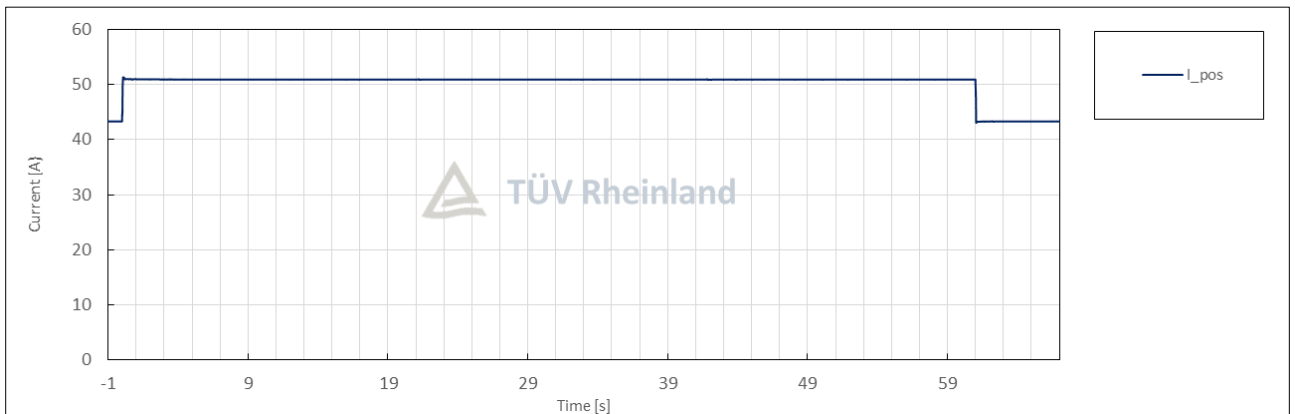
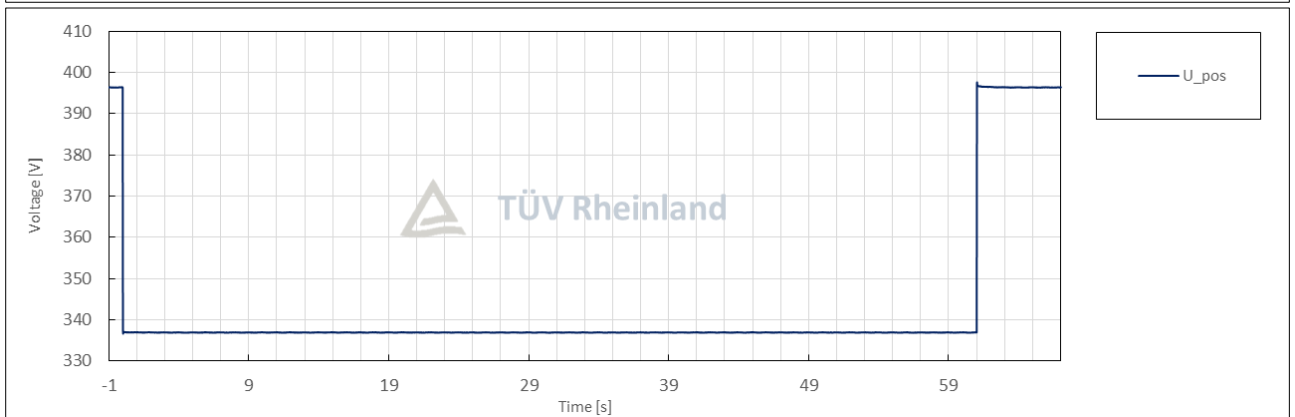
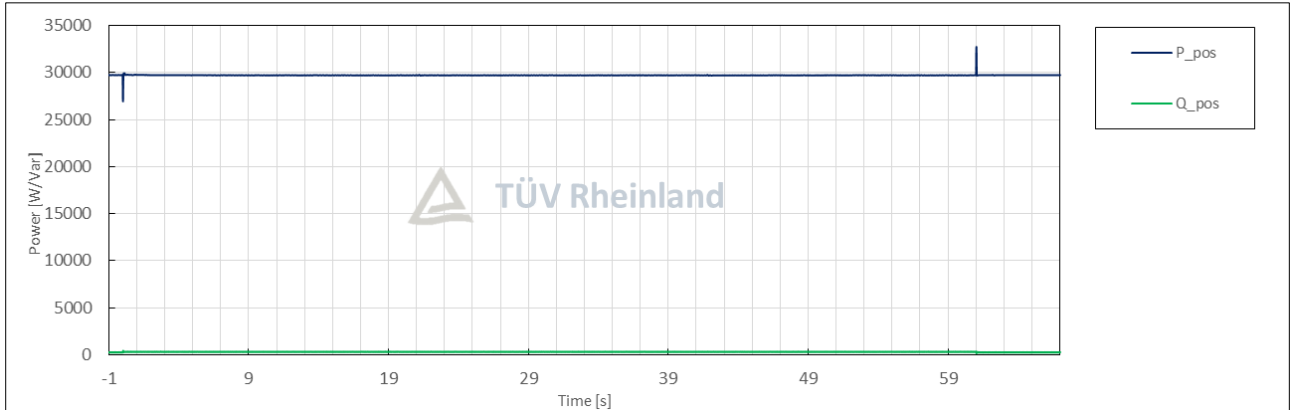

Condition						Measurement
No.	Parameter	Phase ref.	Time ref.	unit		
General Info.	0	Test number	--	--	--	4.3
	1	Date	--	--	dd.mm.yyyy	28.07.2025
	2	Time (start of test)	--	--	hh:mm:ss.f	13:52:23
	3	Fault type (phase)	--	--		2-phase fault
	4	Setting voltage depth	Line to line	--	p.u.	0.85
	5	Setting dip duration		--		61017
	6	Point of fault entry	Total	--	ms	0
	7	Point of fault clearance	Total	--	ms	61017
	8	Fault duration in empty load test	Total	--	ms	61017
	9	Voltage depth/height in empty load test	Total	t1+100ms to t2 and t1-10s to t1	p.u.	0.85
10	Pos.		p.u.		0.90	
Before dip <t1	11	Voltage	Line to neutral	t1-100s to t1	p.u.	1.00
	12	Current	Pos.	t1-500ms to t1-100ms	p.u.	0.99
	13	Active power	Total	t1-10s to t1	p.u.	0.99
	14		Pos.			0.99
	15	Reactive power	Total	t1-10s to t1	p.u.	0.01
	16		Pos.			0.01
17	Cos ϕ	--	t1-10s to t1	--	1.000	
During dip t1 to t2	18	Voltage	Line to neutral	t1+100ms to t2-20ms	p.u.	0.85
	19	Line current	Phase 1	t1+60ms	p.u.	1.07
	20		Phase 2			1.14
	21		Phase 3			1.08
	22	Line current	Phase 1	t1+100ms	p.u.	1.06
	23		Phase 2			1.15
	24		Phase 3			1.07
	25	Active power	Total	t1+100ms to t2-20ms	p.u.	0.98
26	Pos.		0.98			
After dip > t2	27	Voltage	Line to neutral	t2+3s to t2+10s	p.u.	1.00
	28	Active power	Total	t2+3s to t2+10s	p.u.	0.99
	29		Pos.			0.99
	39	Active power rising time	Pos.	--	s	N/A
	31	Reactive power	Total	t2+3s to t2+10s	p.u.	0.01
	32		Pos.			0.01
	33	Reactive power rising time	Pos.	--	s	N/A
34	PGU does not disconnect from grid till 60s after fault	--	t2 to t2+60s	Yes / No	No	

Test No. 4.3 idle test

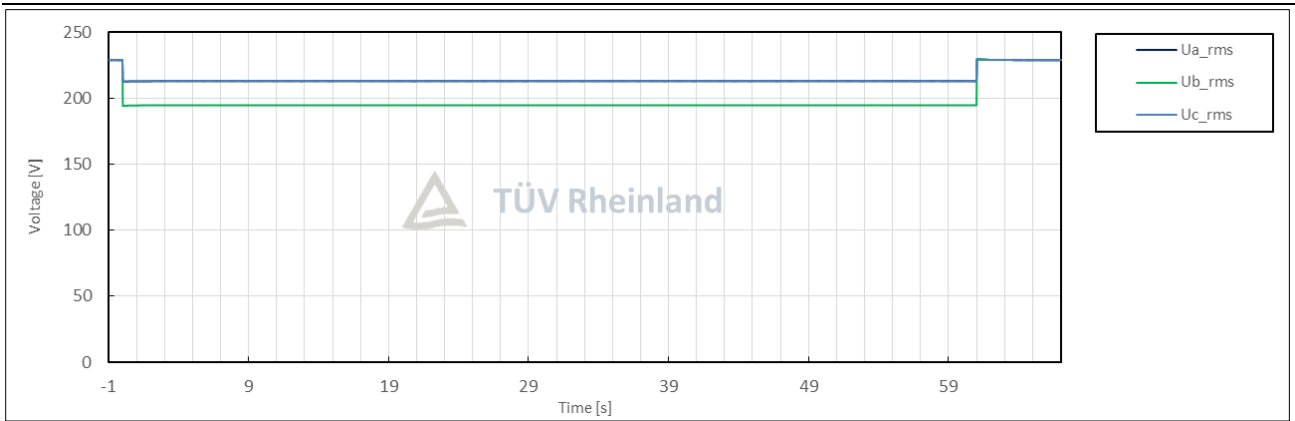
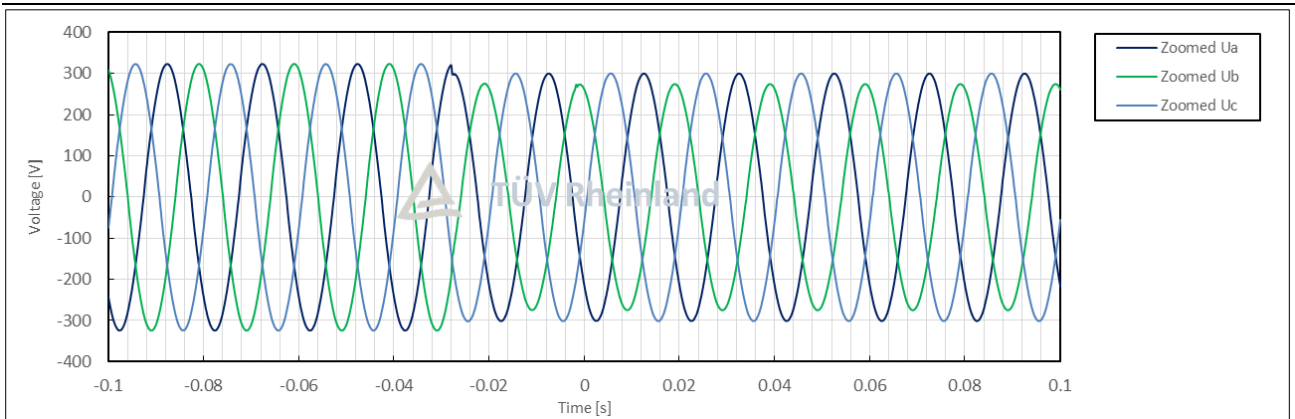
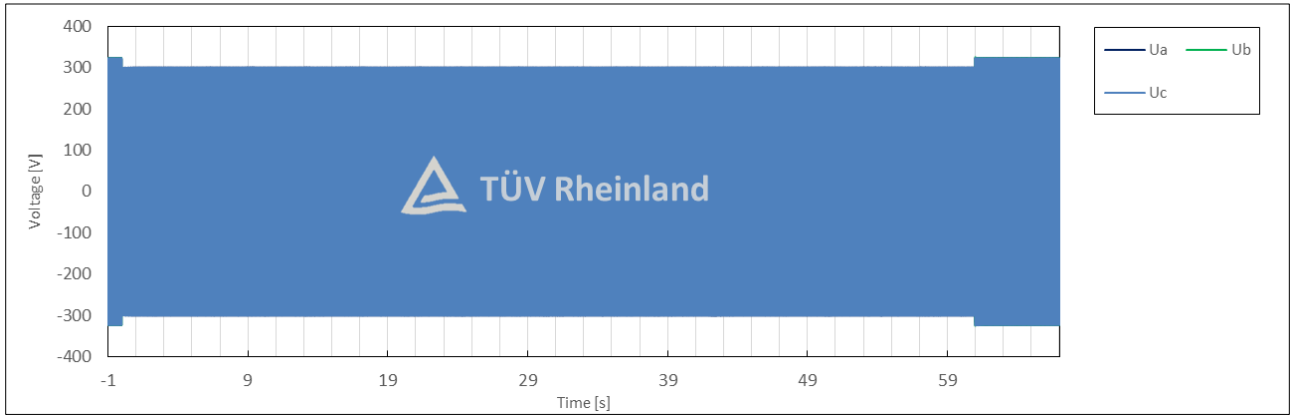

Test No. 4.3 with PGU

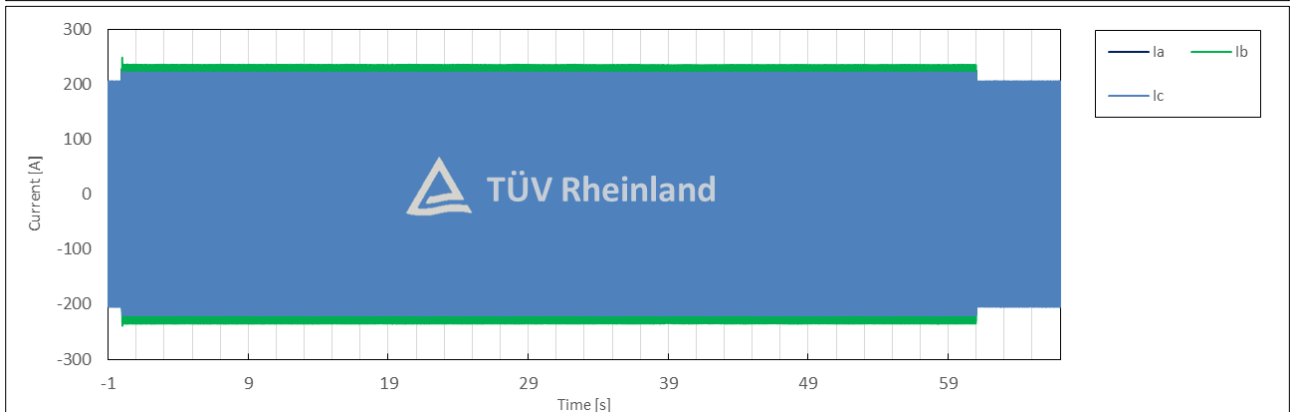
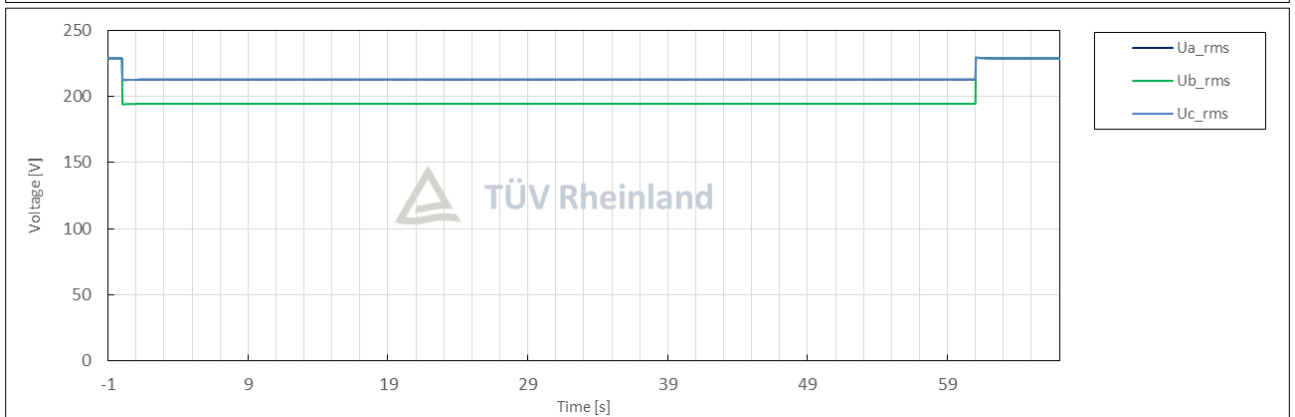
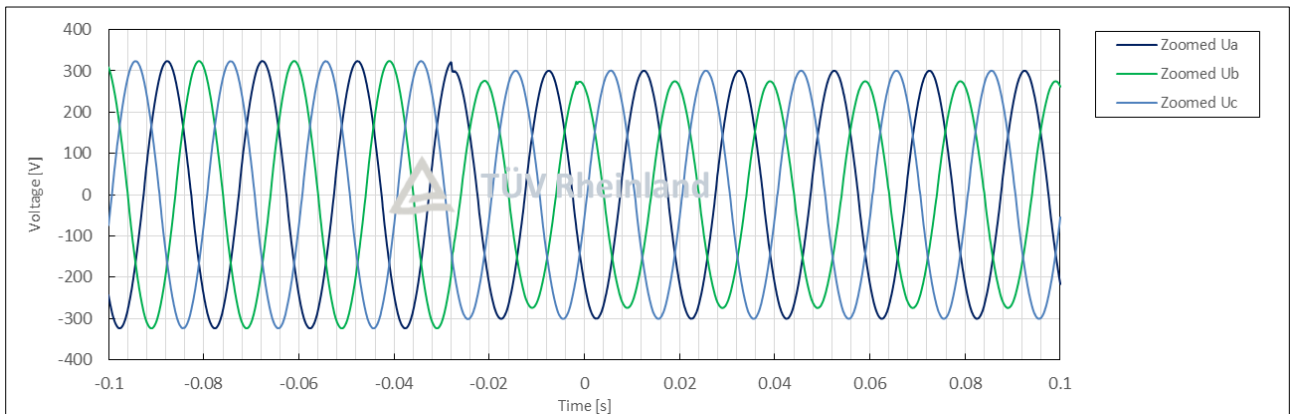
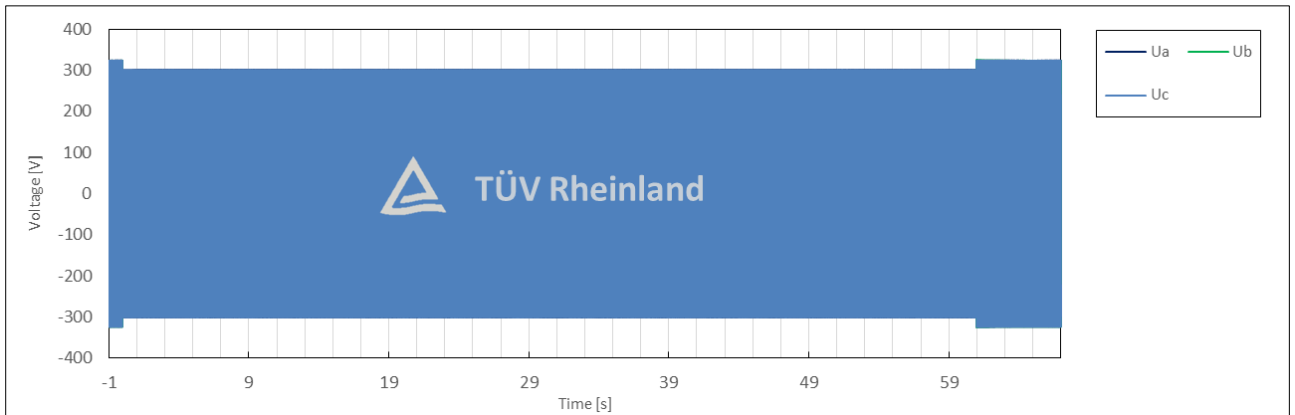

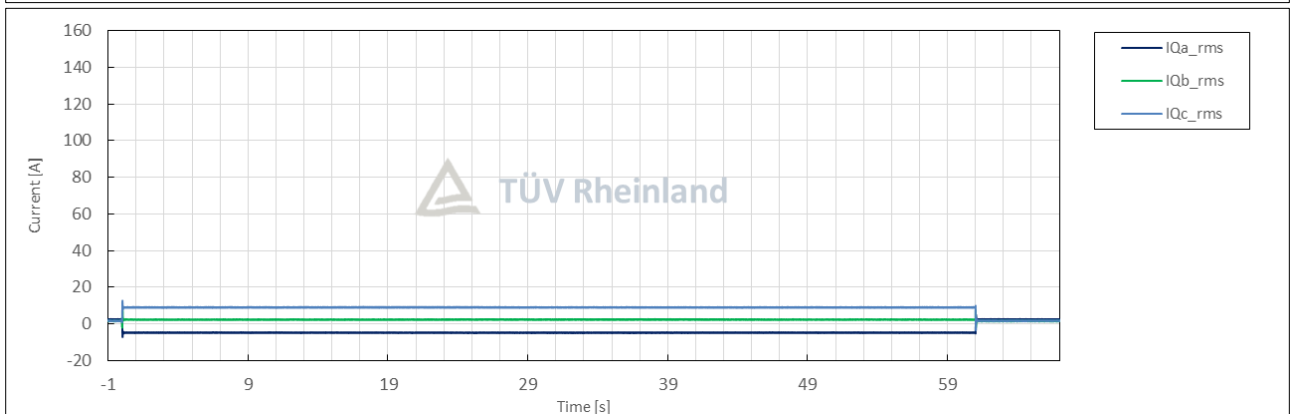
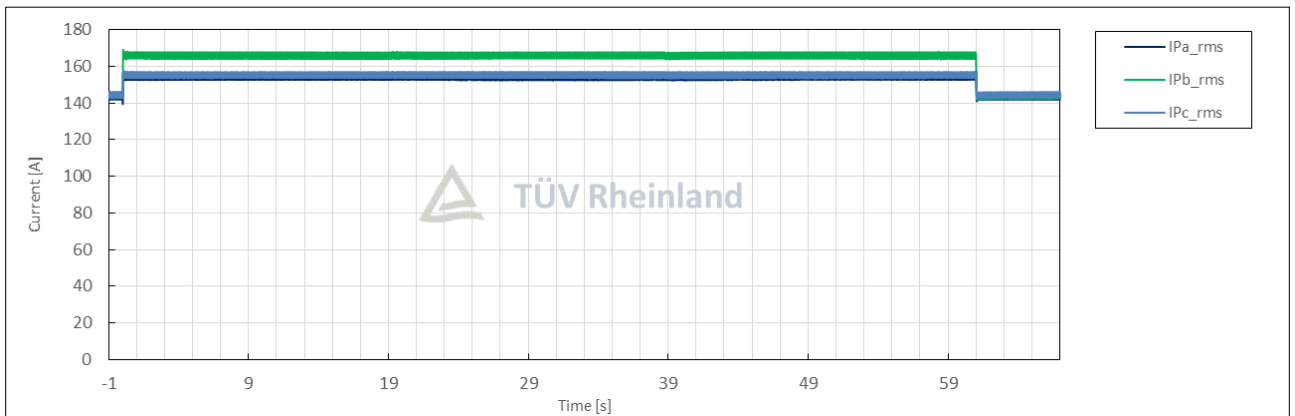
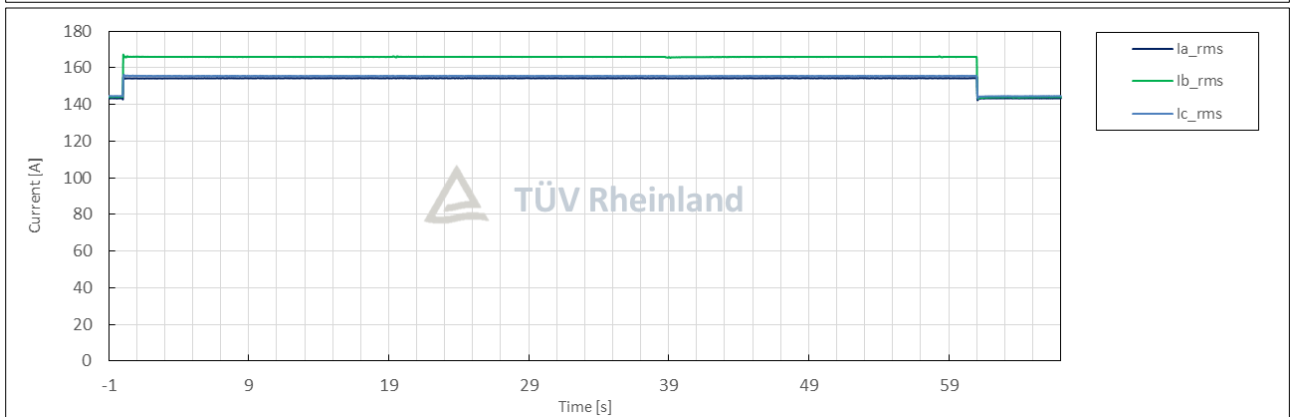
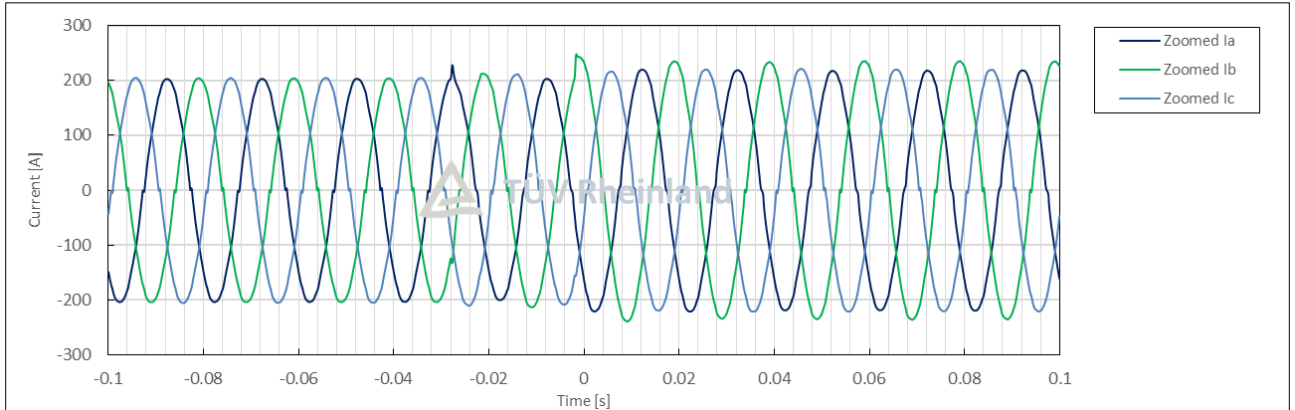

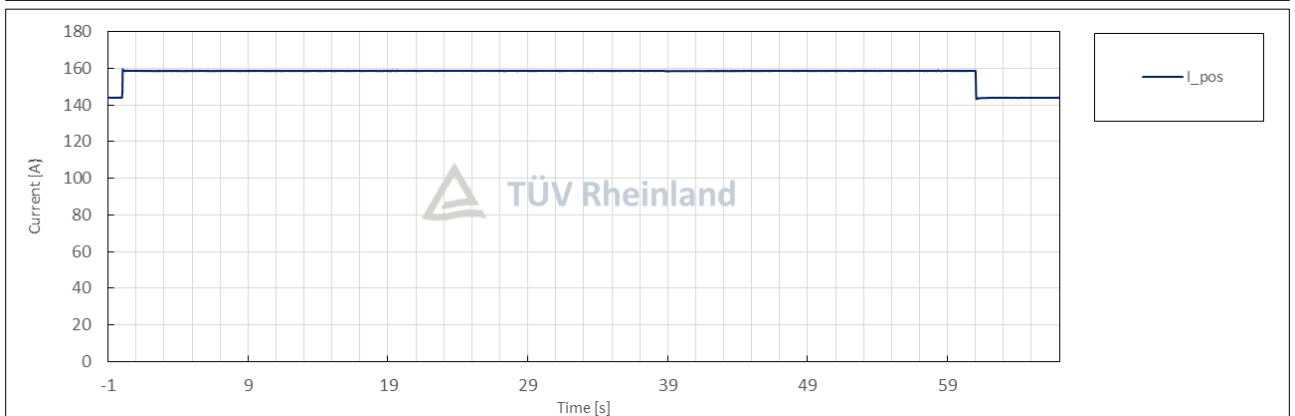
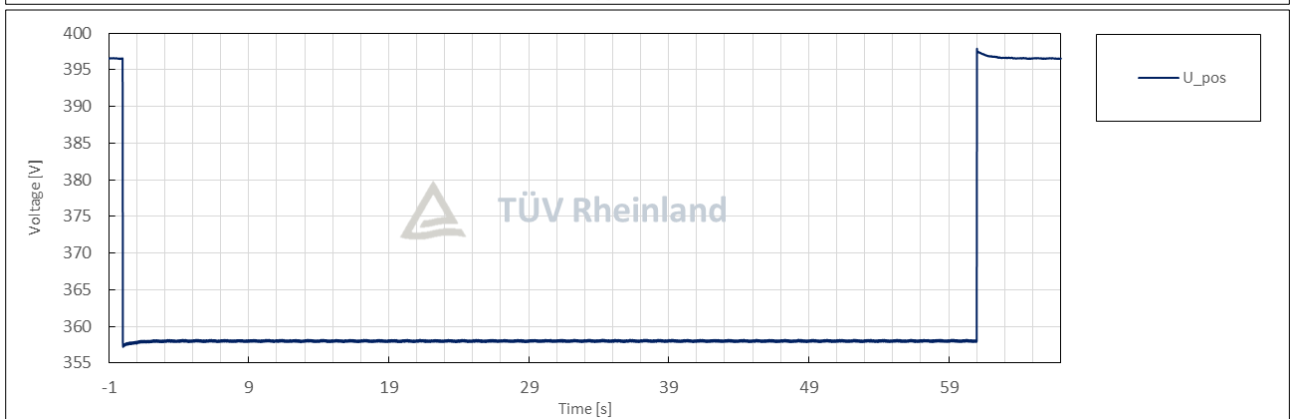
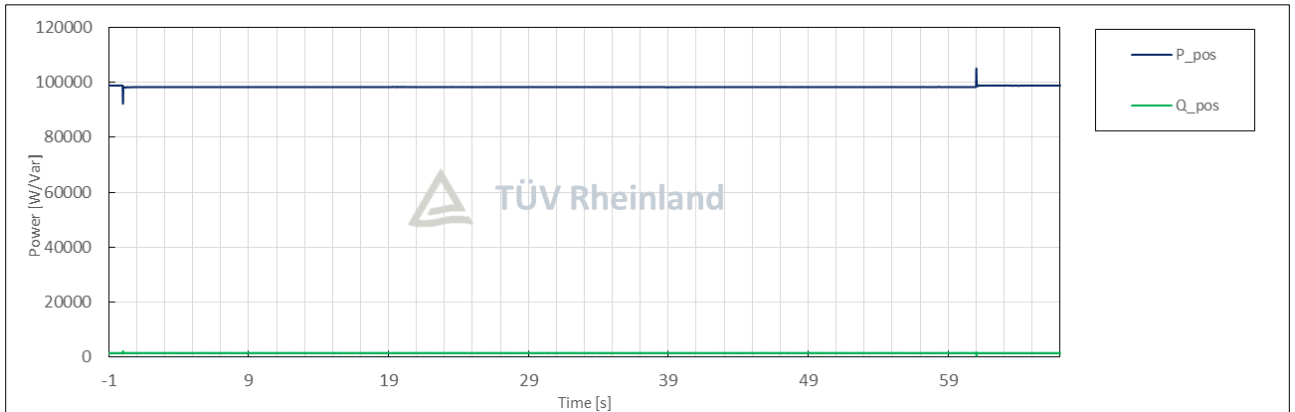

Condition						Measurement
No.	Parameter	Phase ref.	Time ref.	unit		
General Info.	0	Test number	--	--	--	4.4
	1	Date	--	--	dd.mm.yyyy	28.07.2025
	2	Time (start of test)	--	--	hh:mm:ss.f	13:53:24
	3	Fault type (phase)	--	--		2-phase fault
	4	Setting voltage depth	Line to line	--	p.u.	0.85
	5	Setting dip duration		--		61017
	6	Point of fault entry	Total	--	ms	0
	7	Point of fault clearance	Total	--	ms	61017
	8	Fault duration in empty load test	Total	--	ms	61017
	9	Voltage depth/height in empty load test	Total	t1+100ms to t2 and t1-10s to t1	p.u.	0.85
10	Pos.		p.u.		0.90	
Before dip <t1	11	Voltage	Line to neutral	t1-100s to t1	p.u.	0.99
	12	Current	Pos.	t1-500ms to t1-100ms	p.u.	0.30
	13	Active power	Total	t1-10s to t1	p.u.	0.30
	14		Pos.			0.30
	15	Reactive power	Total	t1-10s to t1	p.u.	0.00
	16		Pos.			0.00
17	Cos ϕ	--	t1-10s to t1	--	1.000	
During dip t1 to t2	18	Voltage	Line to neutral	t1+100ms to t2-20ms	p.u.	0.85
	19	Line current	Phase 1	t1+60ms	p.u.	0.32
	20		Phase 2			0.35
	21		Phase 3			0.32
	22	Line current	Phase 1	t1+100ms	p.u.	0.32
	23		Phase 2			0.35
	24		Phase 3			0.33
	25	Active power	Total	t1+100ms to t2-20ms	p.u.	0.30
26	Pos.		0.30			
After dip > t2	27	Voltage	Line to neutral	t2+3s to t2+10s	p.u.	0.99
	28	Active power	Total	t2+3s to t2+10s	p.u.	0.30
	29		Pos.			0.30
	39	Active power rising time	Pos.	--	s	N/A
	31	Reactive power	Total	t2+3s to t2+10s	p.u.	0.00
	32		Pos.			0.00
	33	Reactive power rising time	Pos.	--	s	N/A
34	PGU does not disconnect from grid till 60s after fault	--	t2 to t2+60s	Yes / No	No	

Test No. 4.4 idle test

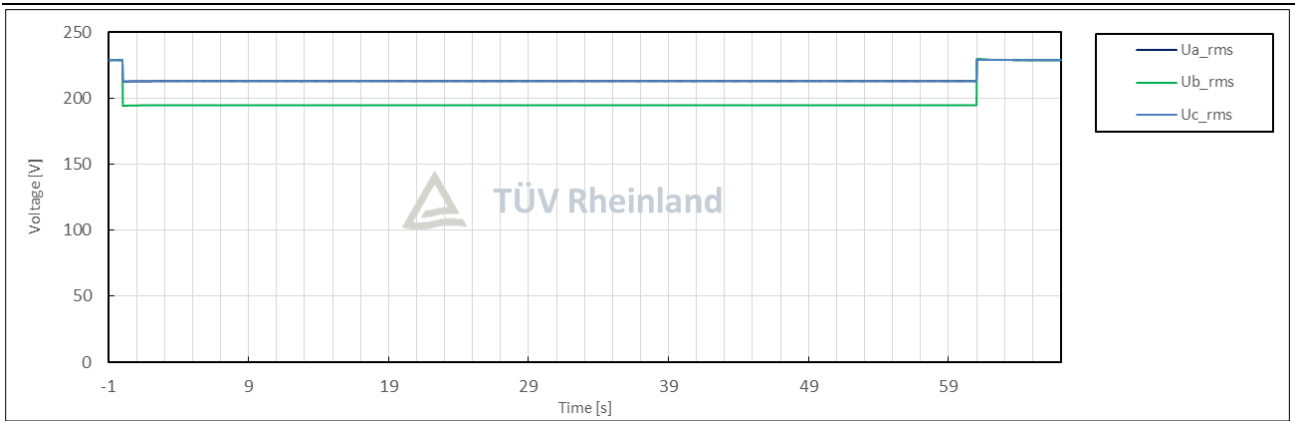
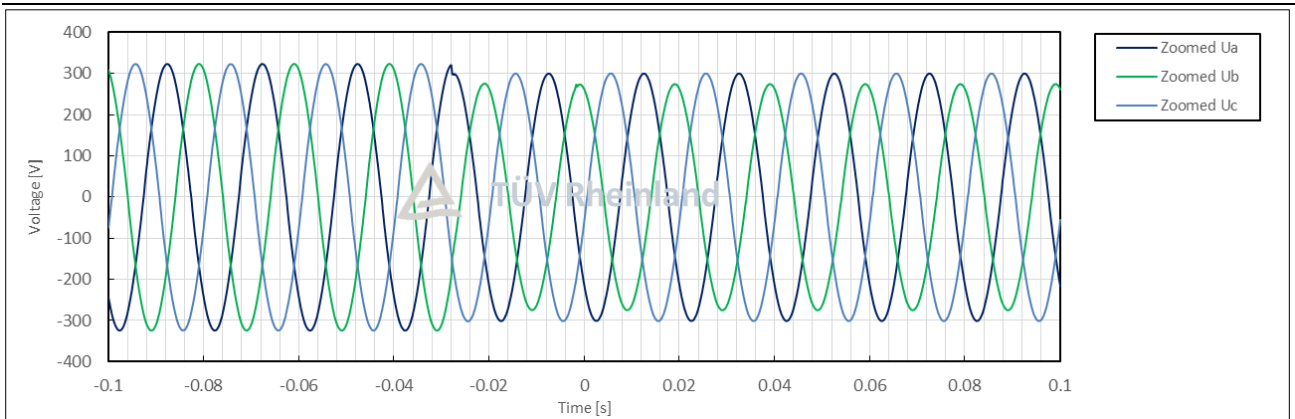
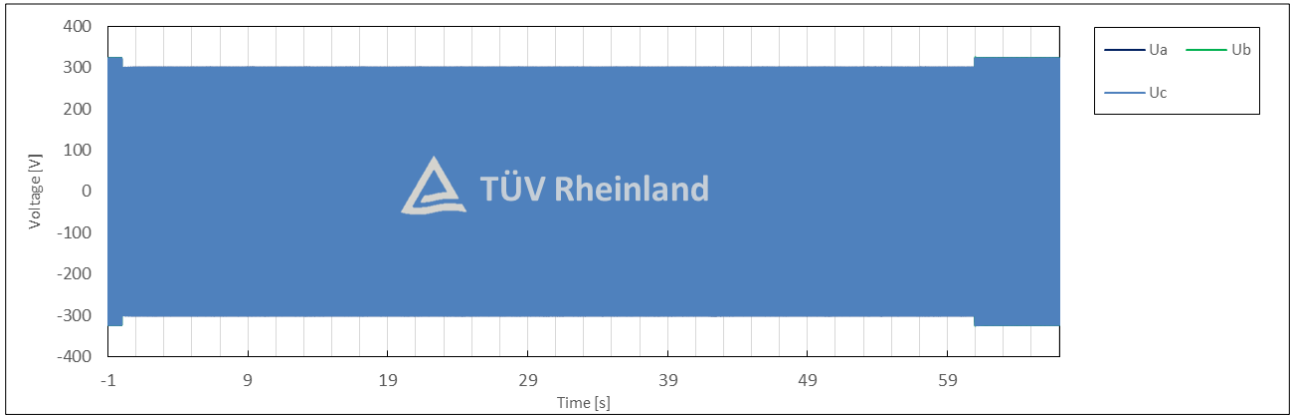

Test No. 4.4 with PGU

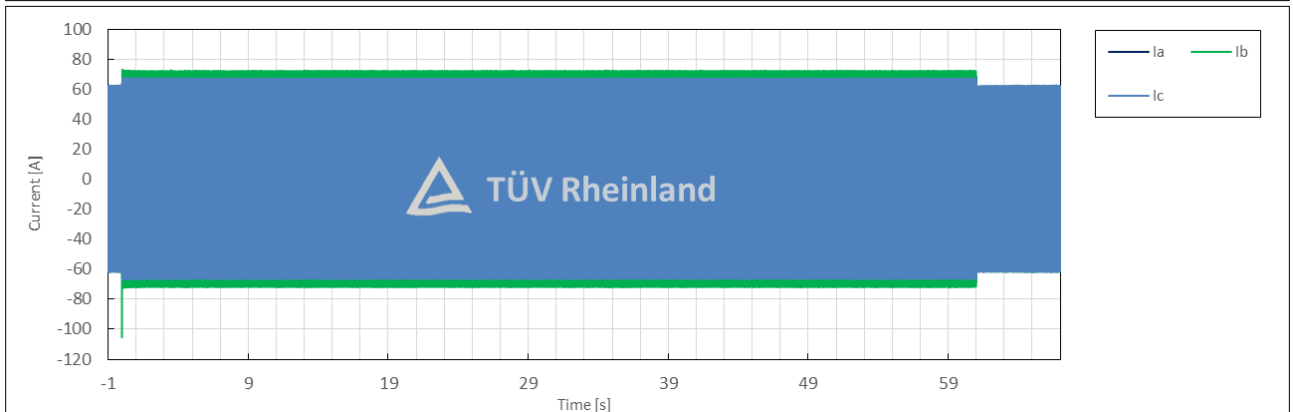
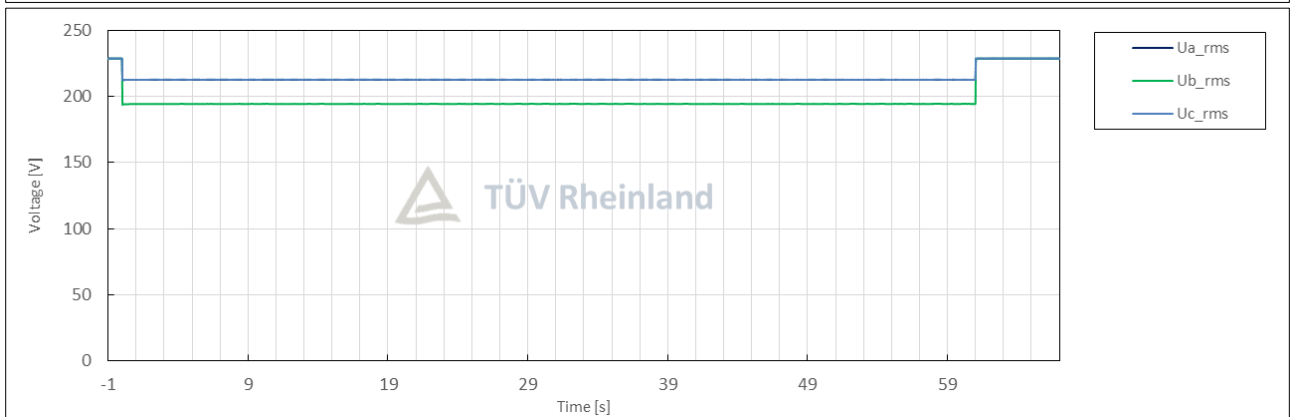
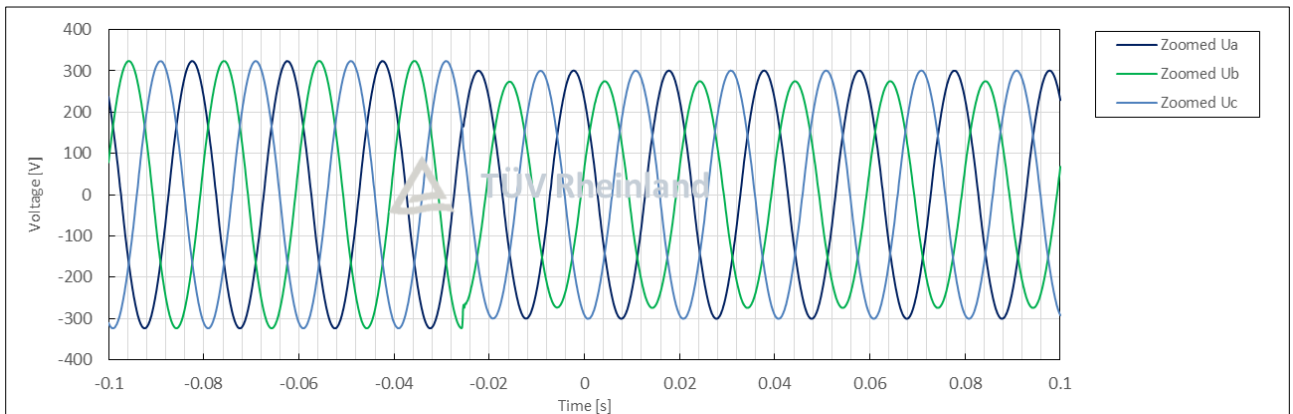
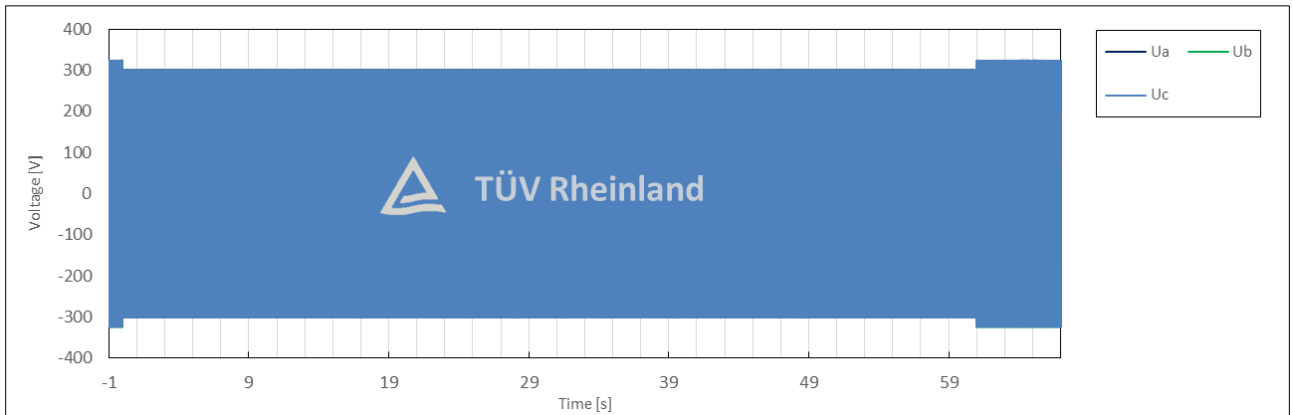

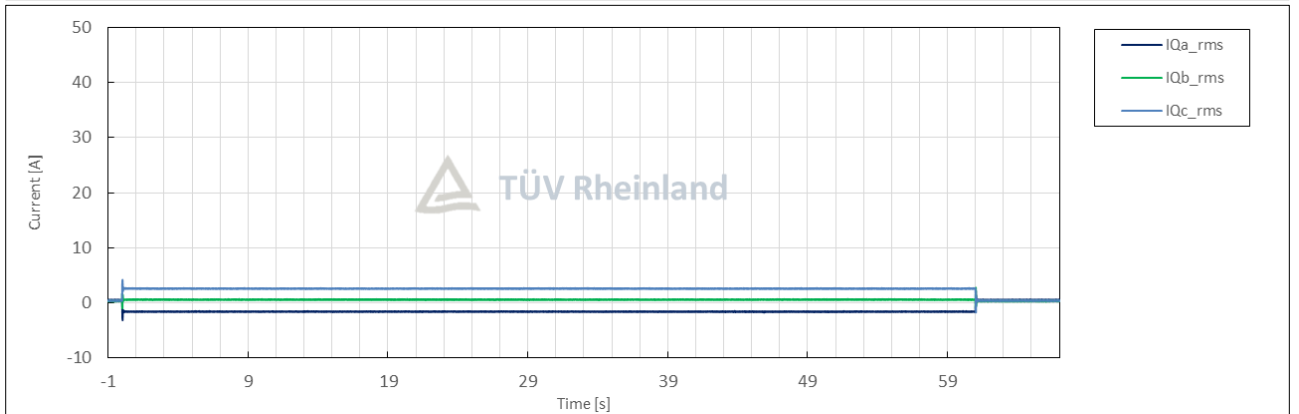
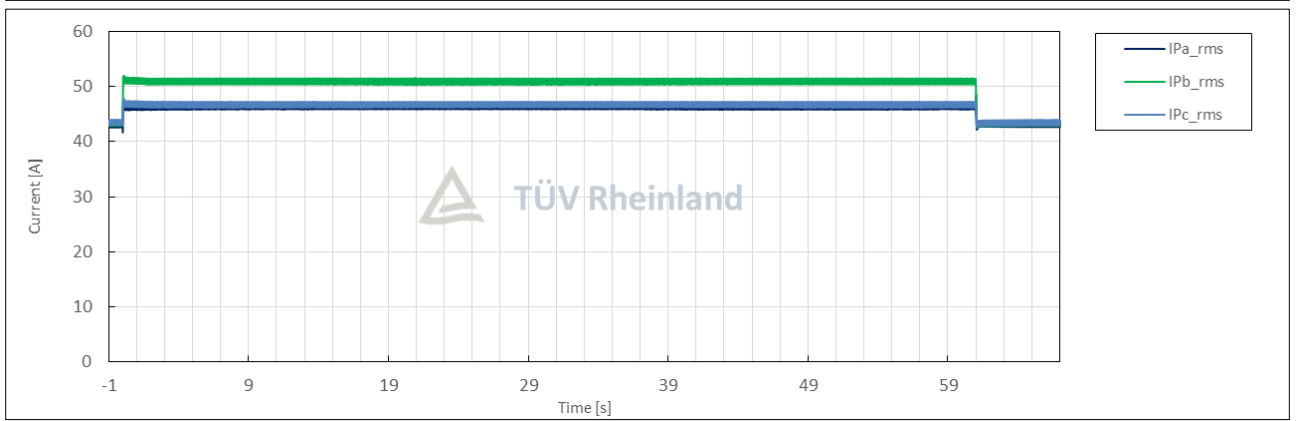
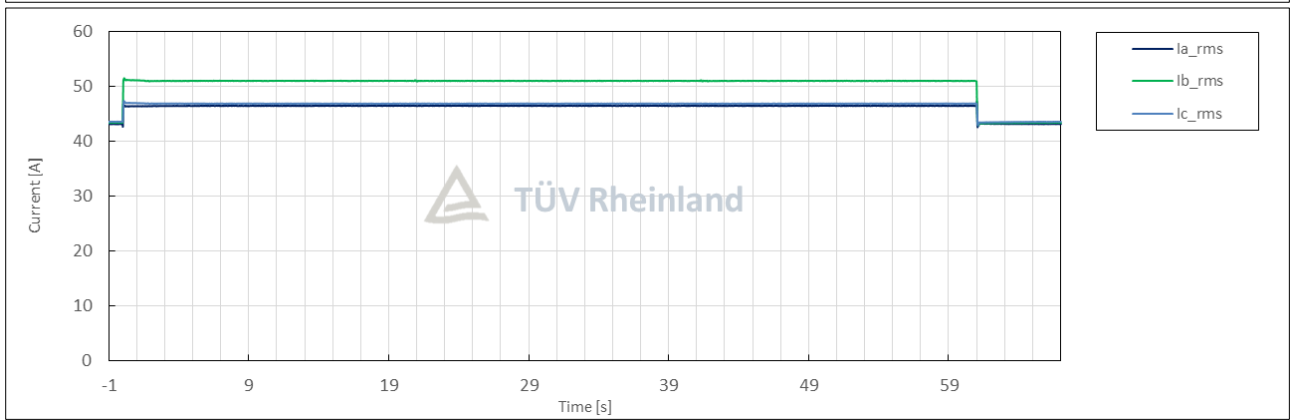
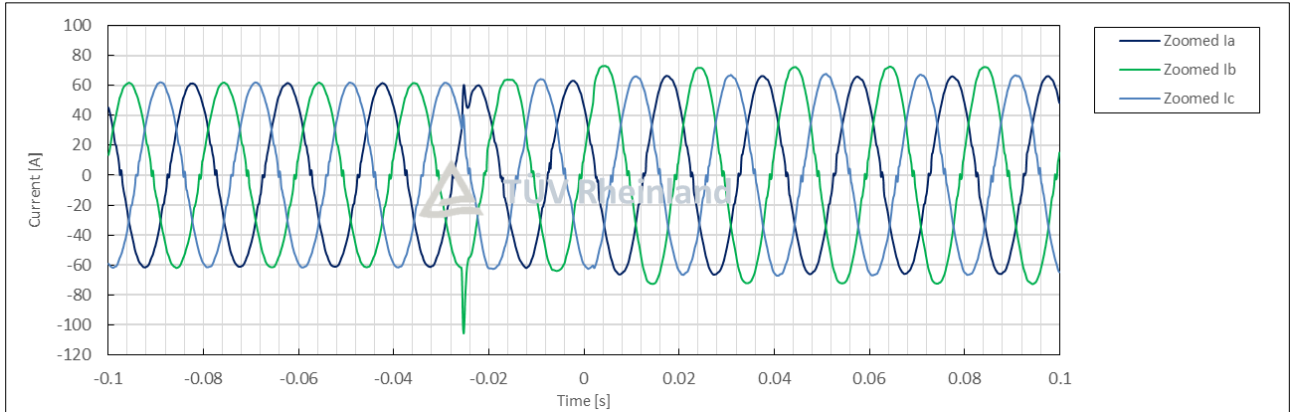

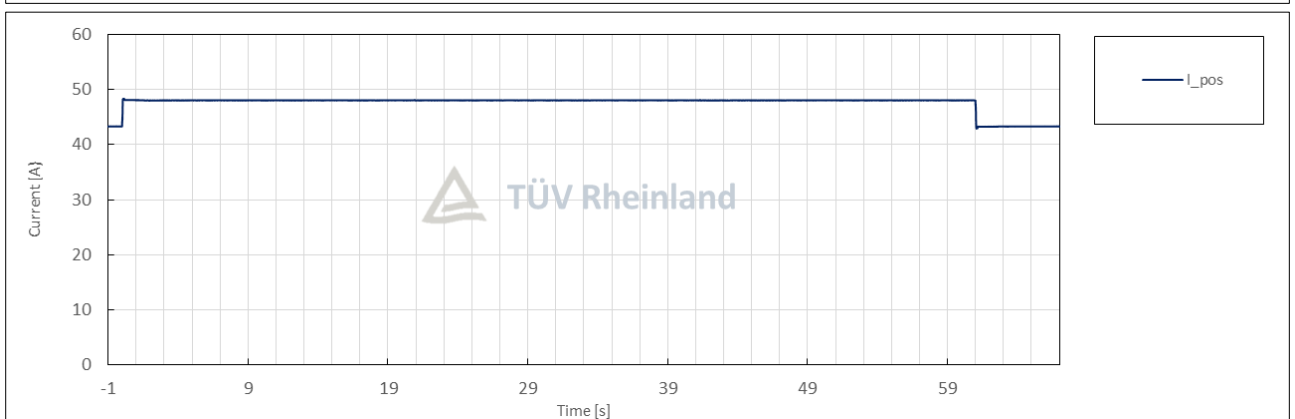
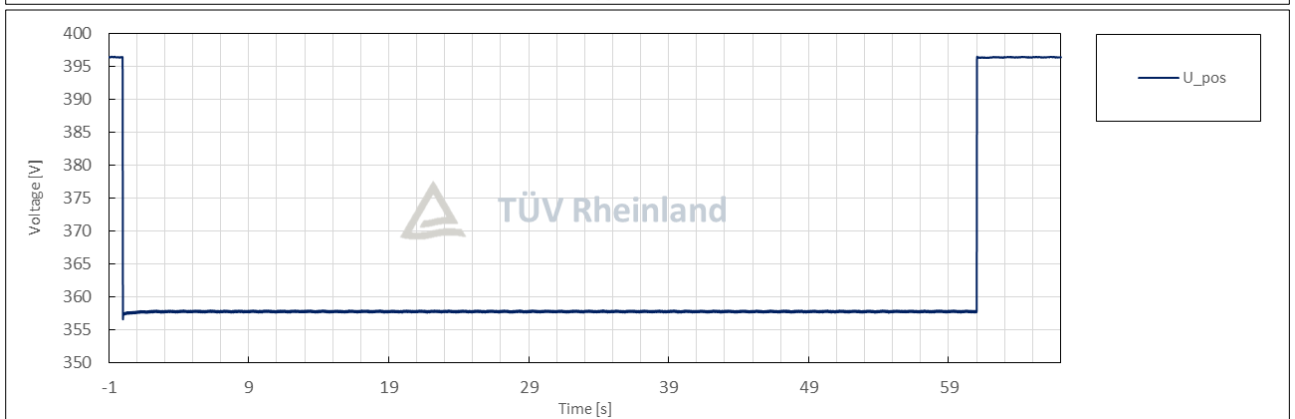
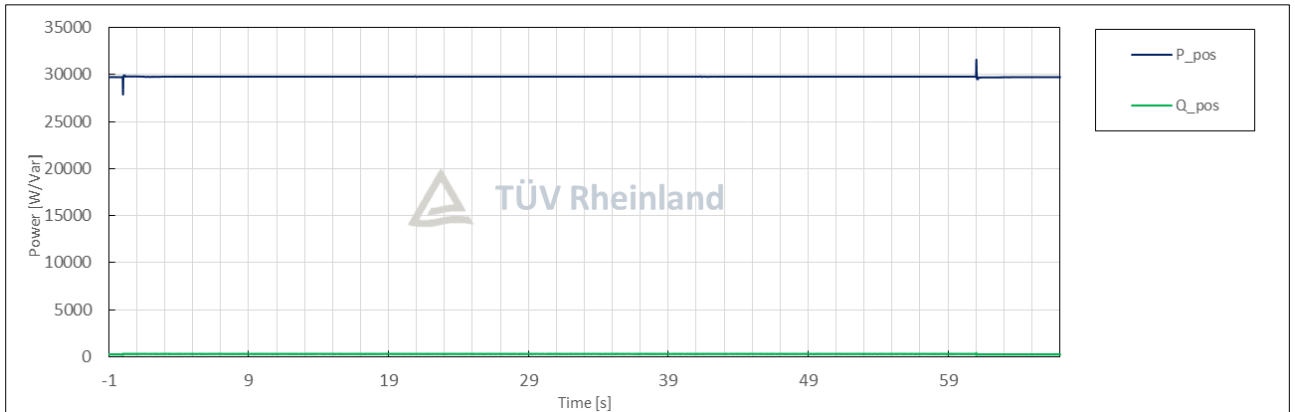

Condition						Measurement
No.	Parameter	Phase ref.	Time ref.	unit		
General Info.	0	Test number	--	--	--	5.1
	1	Date	--	--	dd.mm.yyyy	28.07.2025
	2	Time (start of test)	--	--	hh:mm:ss.f	13:52:38
	3	Fault type (phase)	--	--		3-phase fault
	4	Setting voltage depth	Line to line	--	p.u.	1.25
	5	Setting dip duration		--		154
	6	Point of fault entry	Total	--	ms	0
	7	Point of fault clearance	Total	--	ms	154
	8	Fault duration in empty load test	Total	--	ms	154
	9	Voltage depth/height in empty load test	Total	t1+100ms to t2 and t1-10s to t1	p.u.	1.26
	10		Pos.		p.u.	1.26
Before dip <t1	11	Voltage	Line to neutral	t1-100s to t1	p.u.	1.00
	12	Current	Pos.	t1-500ms to t1-100ms	p.u.	0.99
	13	Active power	Total	t1-10s to t1	p.u.	0.99
	14		Pos.			0.99
	15	Reactive power	Total	t1-10s to t1	p.u.	0.01
	16		Pos.			0.01
	17	Cos ϕ	--	t1-10s to t1	--	1.000
During dip t1 to t2	18	Voltage	Line to neutral	t1+100ms to t2-20ms	p.u.	1.25
	19	Line current	Phase 1	t1+60ms	p.u.	0.02
	20		Phase 2			0.02
	21		Phase 3			0.02
	22	Line current	Phase 1	t1+100ms	p.u.	0.02
	23		Phase 2			0.02
	24		Phase 3			0.02
	25	Active power	Total	t1+100ms to t2-20ms	p.u.	0.00
	26		Pos.			0.00
After dip > t2	27	Voltage	Line to neutral	t2+3s to t2+10s	p.u.	1.00
	28	Active power	Total	t2+3s to t2+10s	p.u.	0.99
	29		Pos.			0.99
	39	Active power rising time	Pos.	--	s	0.033
	31	Reactive power	Total	t2+3s to t2+10s	p.u.	0.01
	32		Pos.			0.01
	33	Reactive power rising time	Pos.	--	s	N/A
	34	PGU does not disconnect from grid till 60s after fault	--	t2 to t2+60s	Yes / No	No

Test No. 5.1 idle test

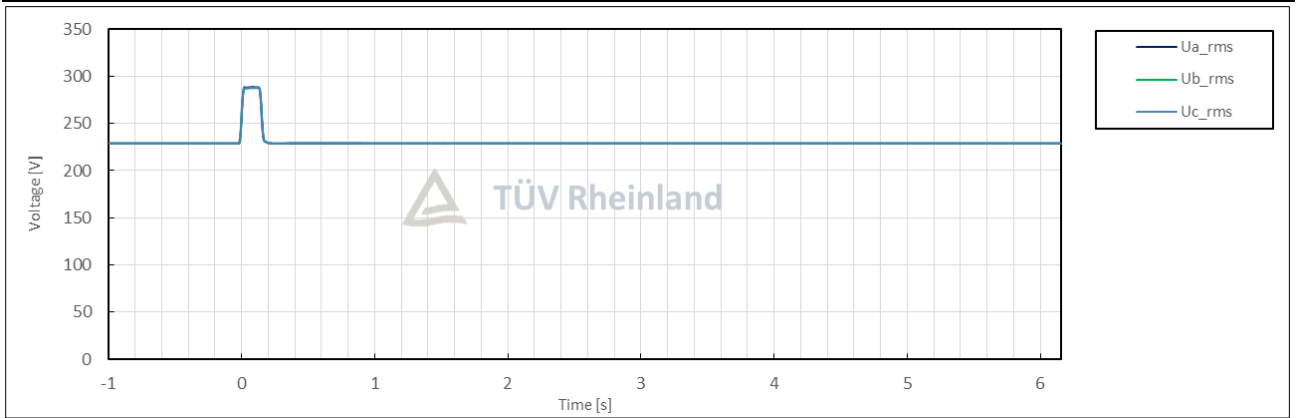
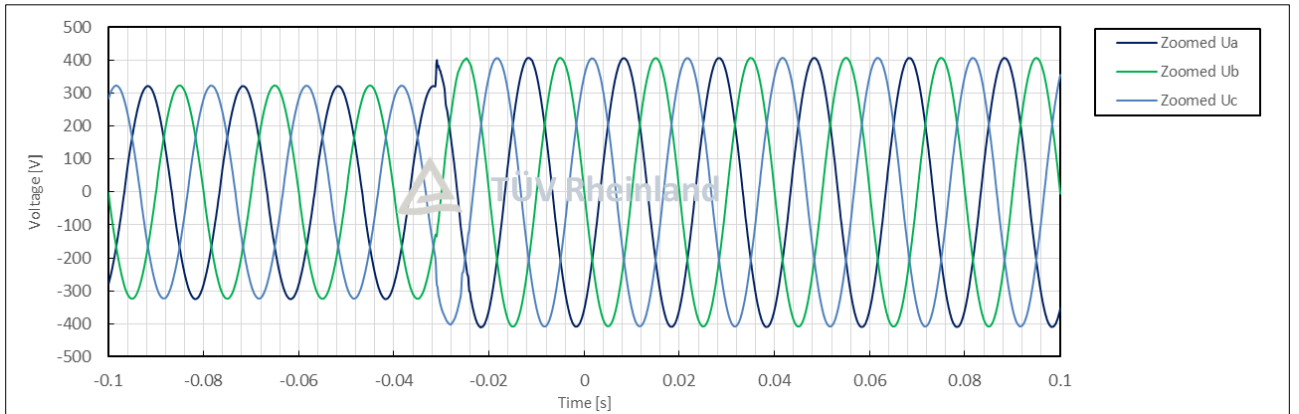
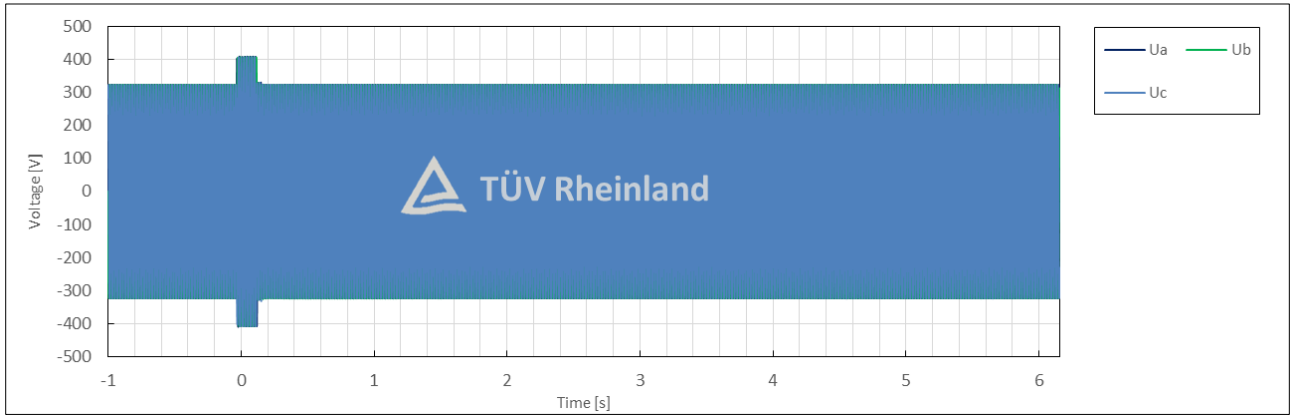

Test No. 5.1 with PGU

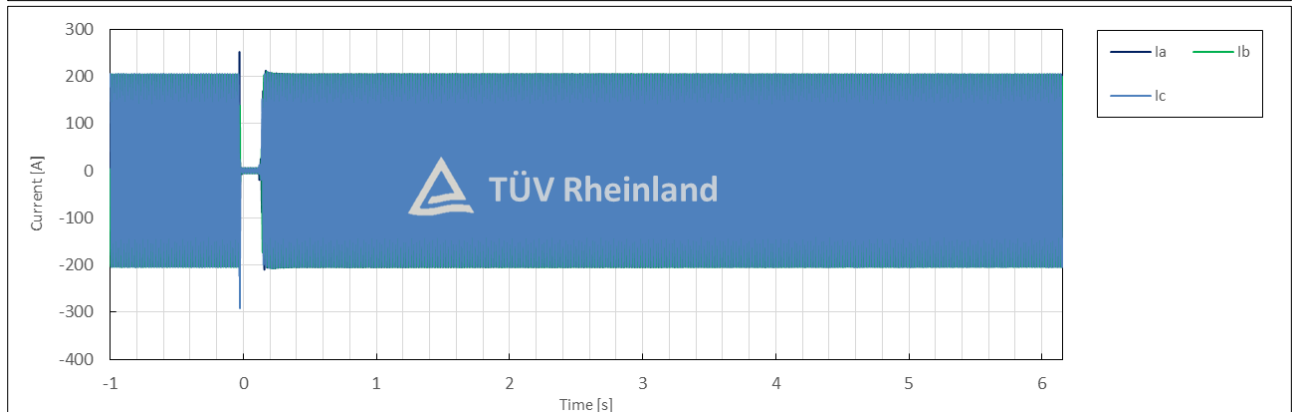
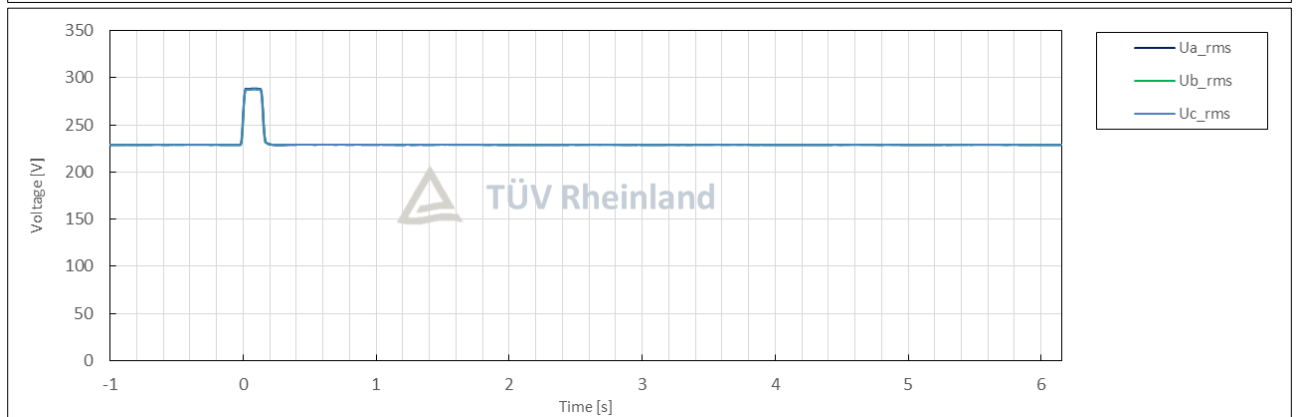
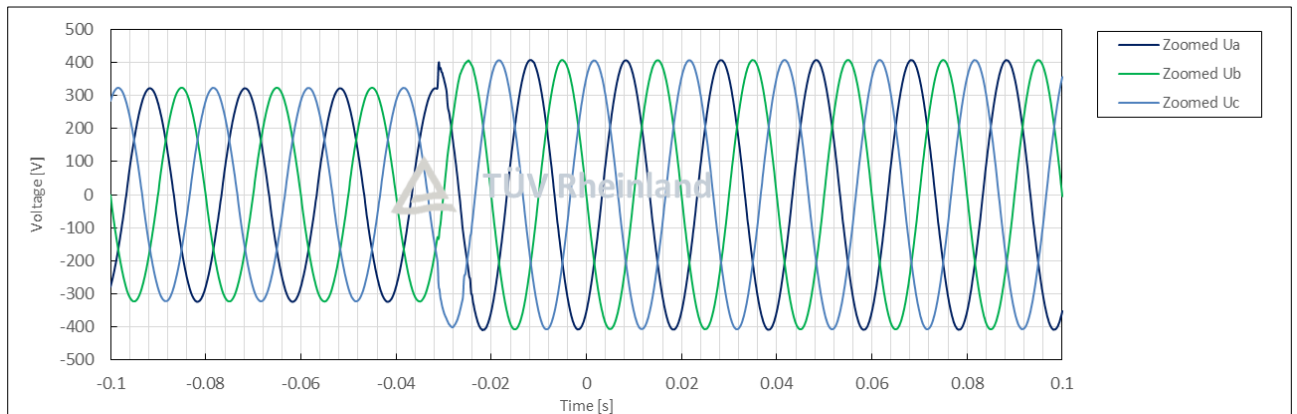
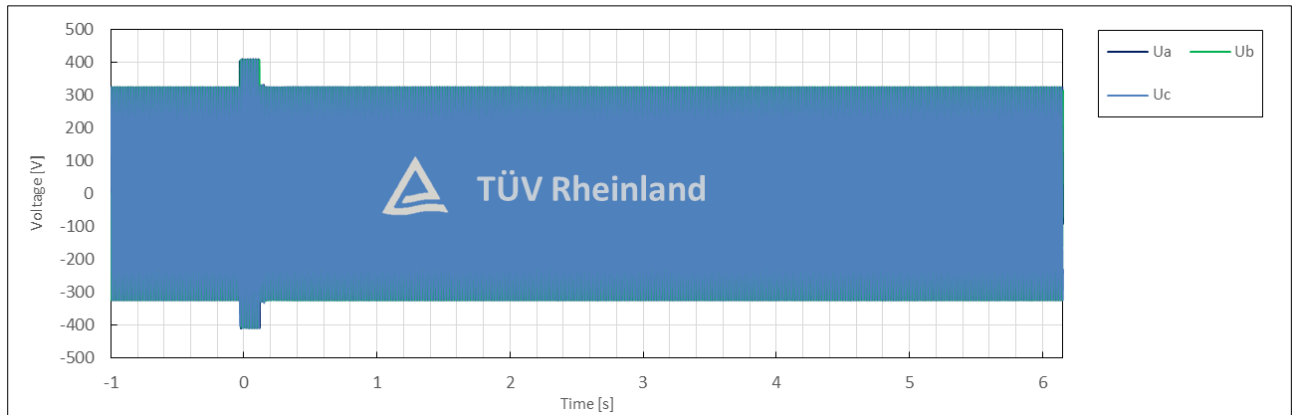

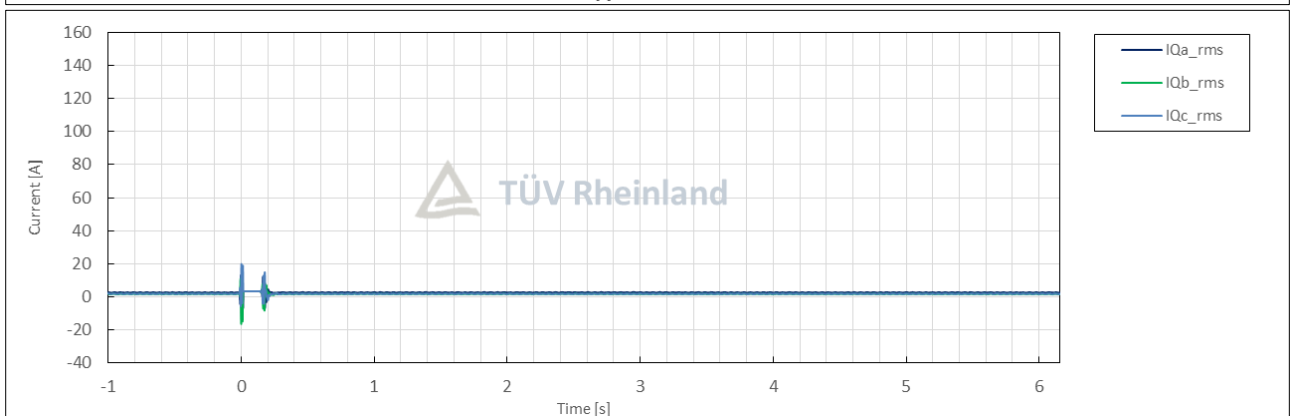
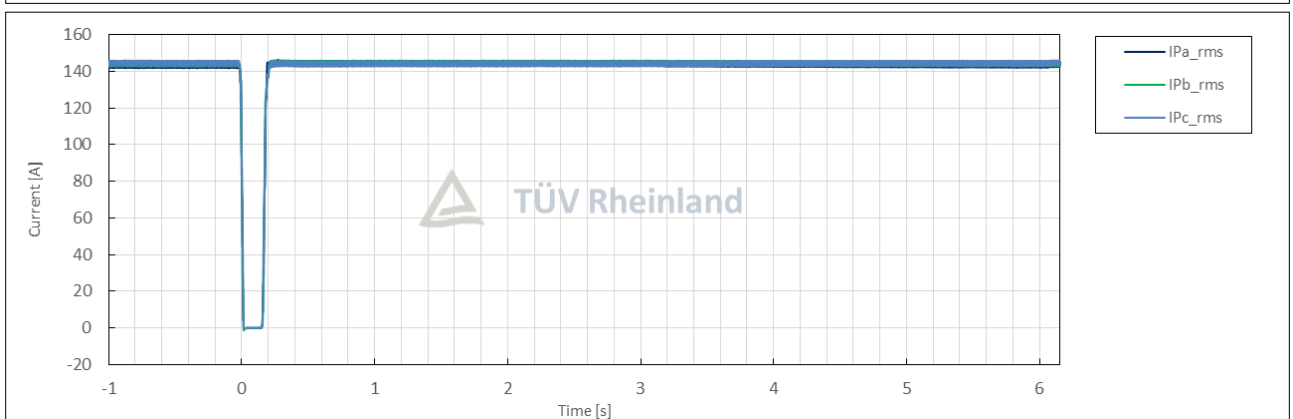
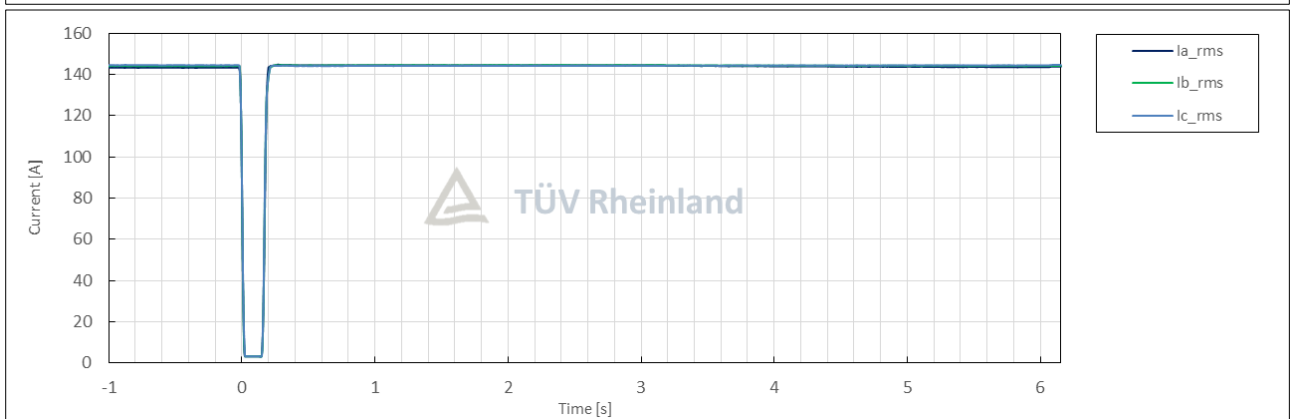
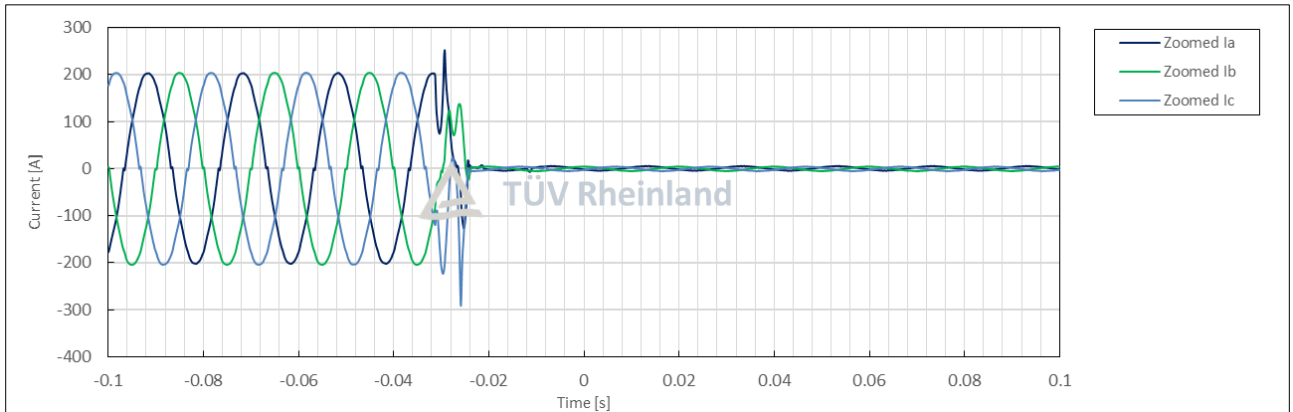

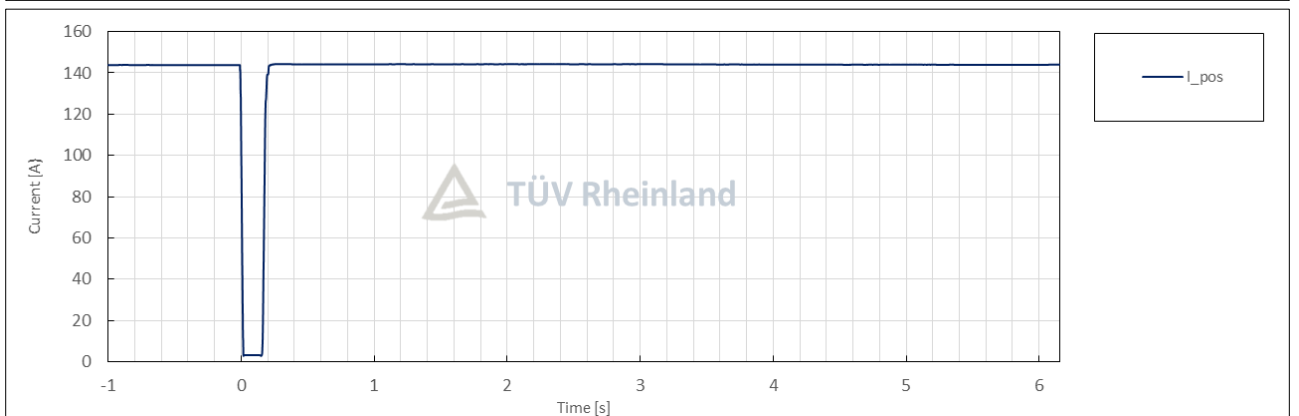
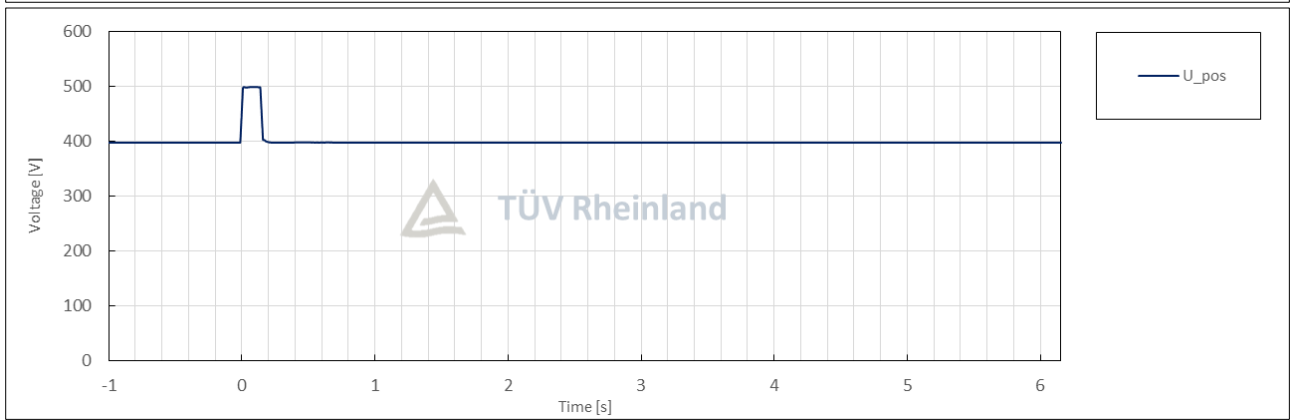
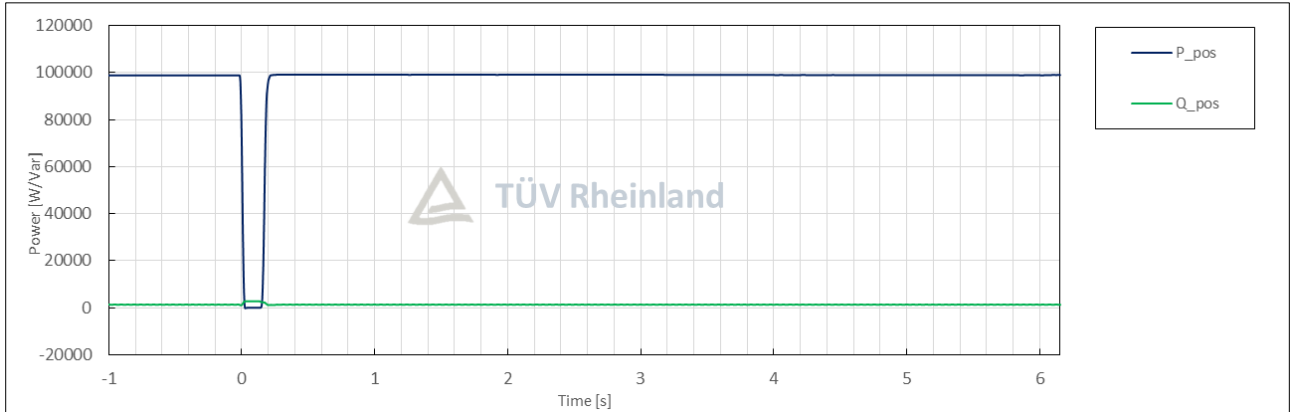

Condition						Measurement
No.	Parameter	Phase ref.	Time ref.	unit		
General Info.	0	Test number	--	--	--	5.2
	1	Date	--	--	dd.mm.yyyy	28.07.2025
	2	Time (start of test)	--	--	hh:mm:ss.f	13:52:49
	3	Fault type (phase)	--	--		3-phase fault
	4	Setting voltage depth	Line to line	--	p.u.	1.25
	5	Setting dip duration		--		154
	6	Point of fault entry	Total	--	ms	0
	7	Point of fault clearance	Total	--	ms	154
	8	Fault duration in empty load test	Total	--	ms	154
	9	Voltage depth/height in empty load test	Total	t1+100ms to t2 and t1-10s to t1	p.u.	1.26
	10		Pos.		p.u.	1.26
Before dip <t1	11	Voltage	Line to neutral	t1-100s to t1	p.u.	1.00
	12	Current	Pos.	t1-500ms to t1-100ms	p.u.	0.30
	13	Active power	Total	t1-10s to t1	p.u.	0.30
	14		Pos.			0.30
	15	Reactive power	Total	t1-10s to t1	p.u.	0.00
	16		Pos.			0.00
	17	Cos ϕ	--	t1-10s to t1	--	1.000
During dip t1 to t2	18	Voltage	Line to neutral	t1+100ms to t2-20ms	p.u.	1.24
	19	Line current	Phase 1	t1+60ms	p.u.	0.02
	20		Phase 2			0.02
	21		Phase 3			0.02
	22	Line current	Phase 1	t1+100ms	p.u.	0.02
	23		Phase 2			0.02
	24		Phase 3			0.02
	25	Active power	Total	t1+100ms to t2-20ms	p.u.	0.00
	26		Pos.			0.00
After dip > t2	27	Voltage	Line to neutral	t2+3s to t2+10s	p.u.	0.99
	28	Active power	Total	t2+3s to t2+10s	p.u.	0.30
	29		Pos.			0.30
	39	Active power rising time	Pos.	--	s	0.025
	31	Reactive power	Total	t2+3s to t2+10s	p.u.	0.00
	32		Pos.			0.00
	33	Reactive power rising time	Pos.	--	s	N/A
	34	PGU does not disconnect from grid till 60s after fault	--	t2 to t2+60s	Yes / No	No

Test No. 5.2 idle test

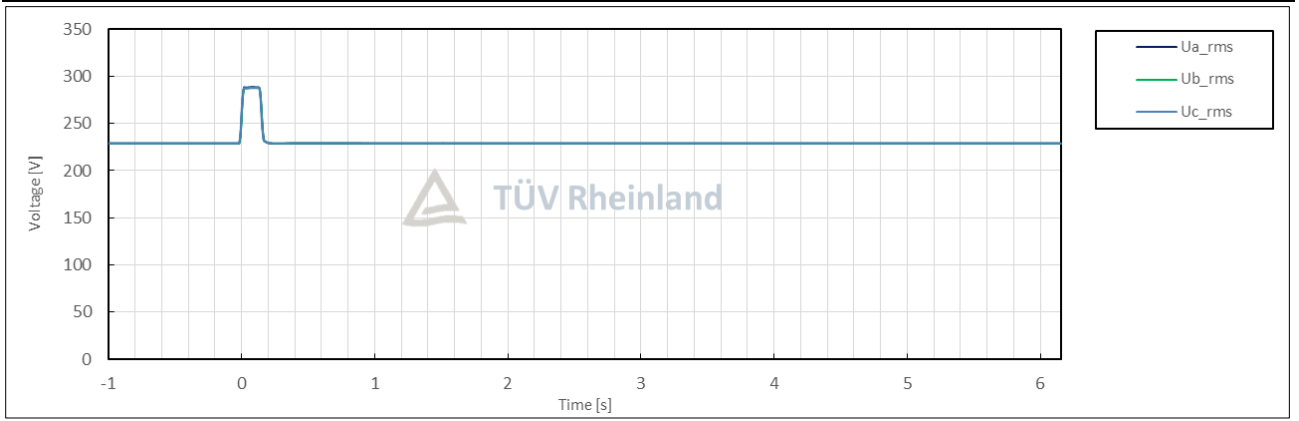
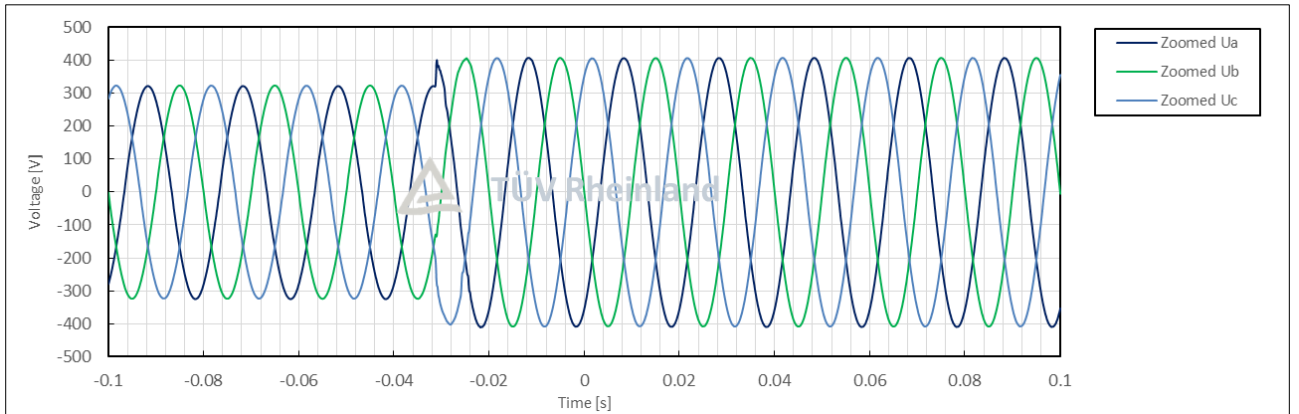
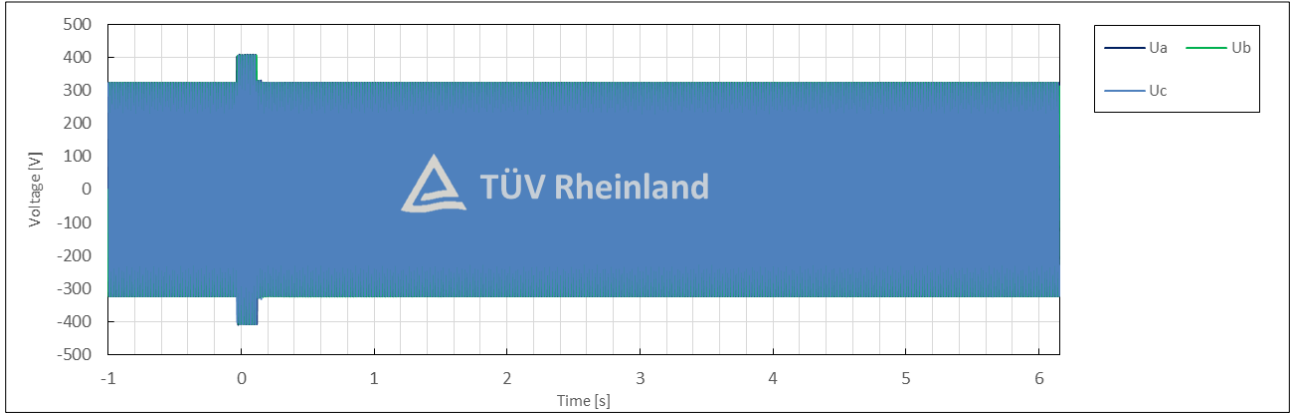

Test No. 5.2 with PGU

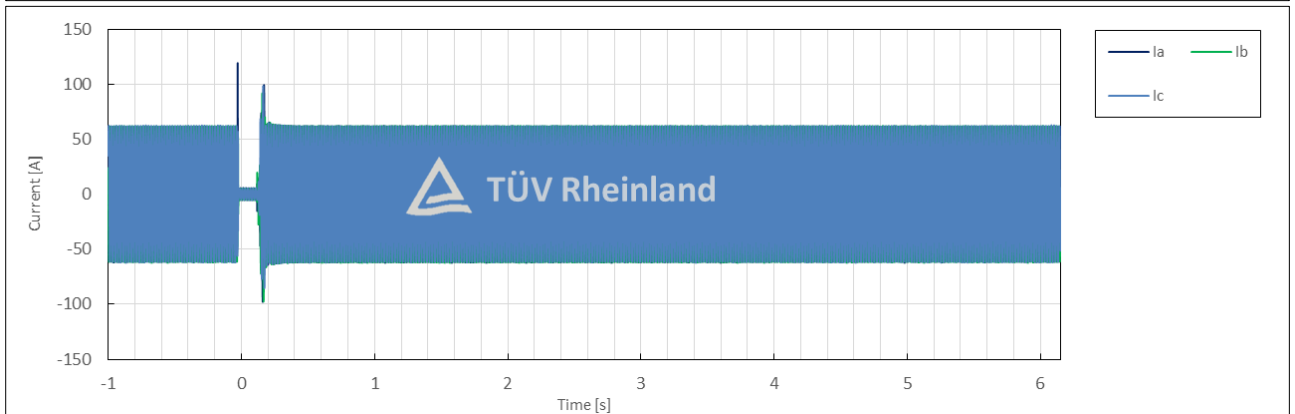
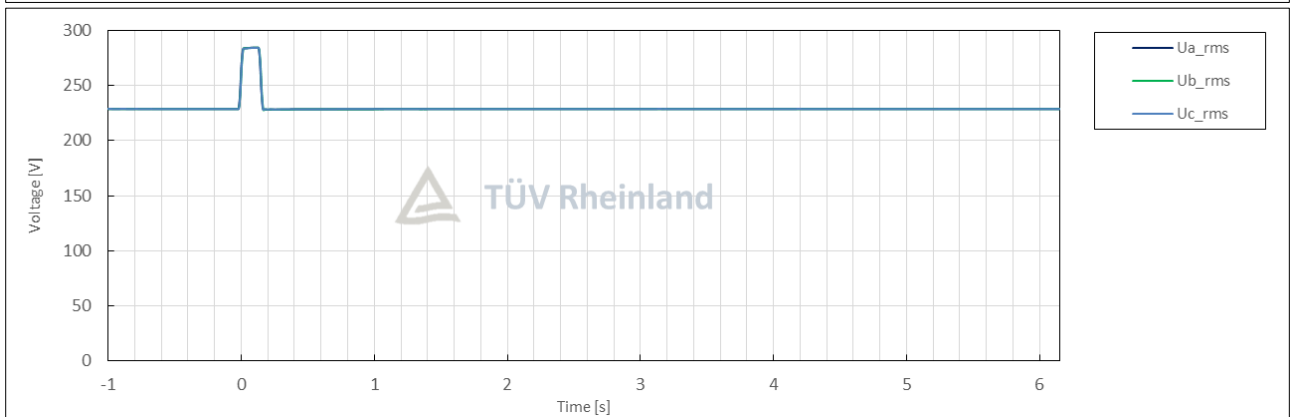
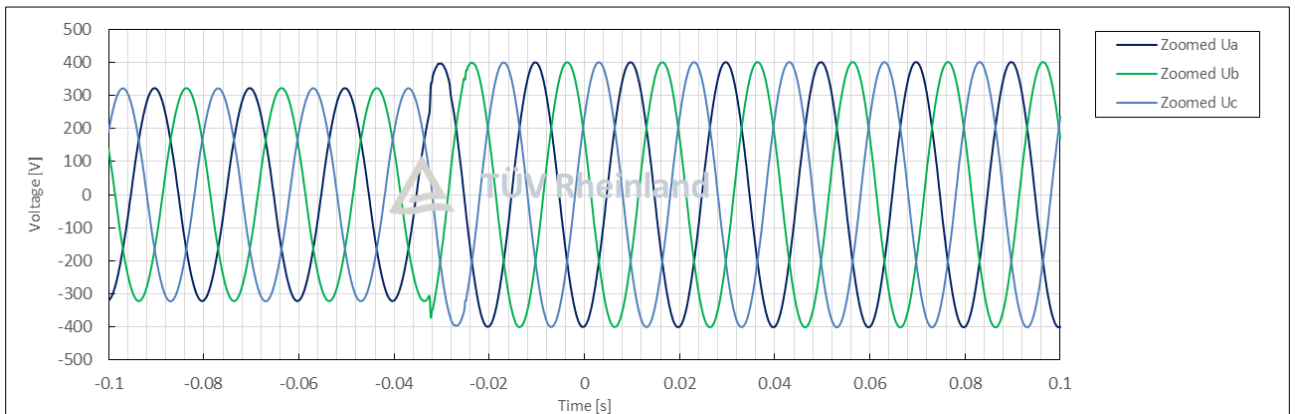
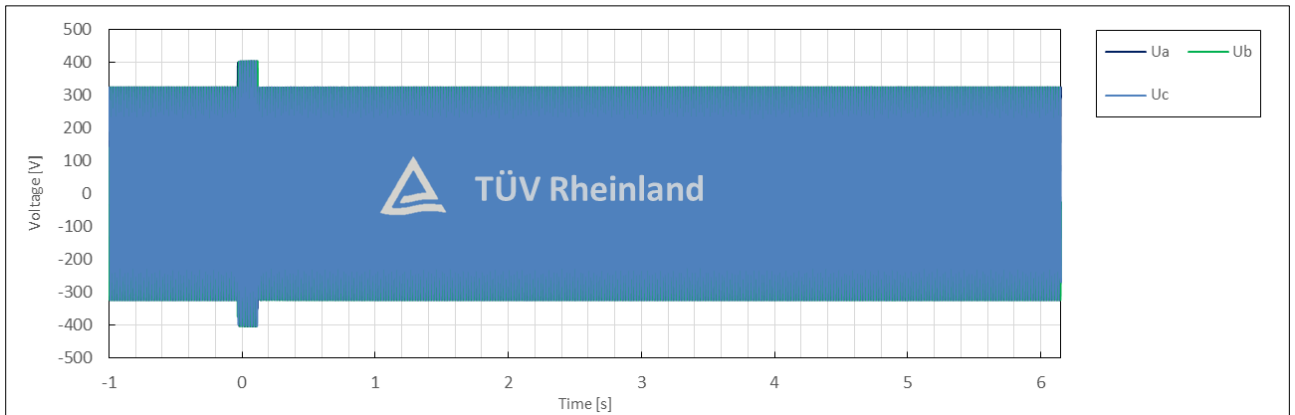

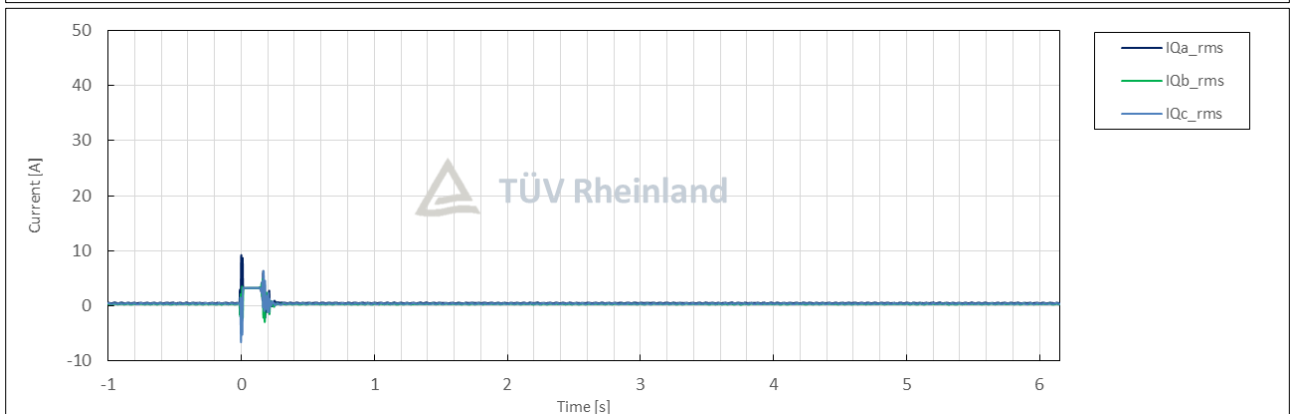
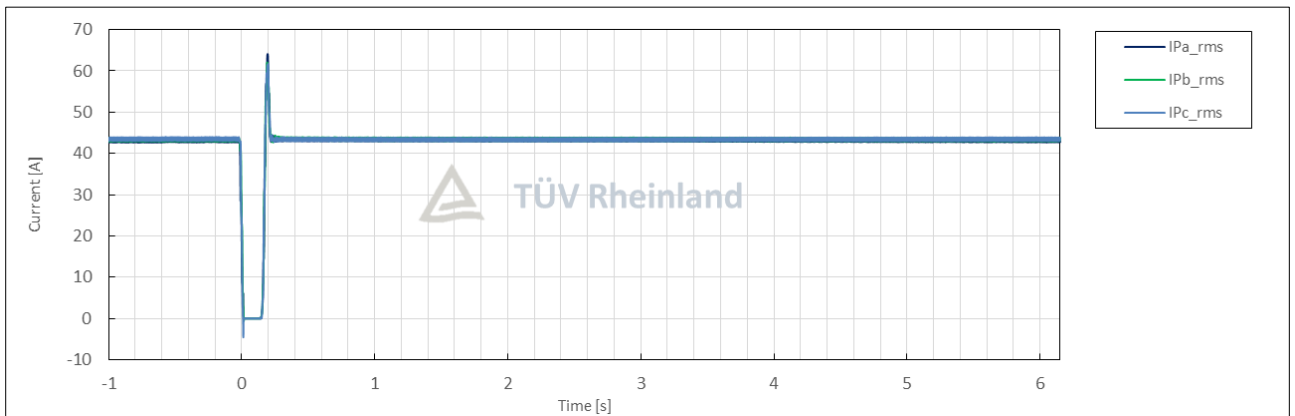
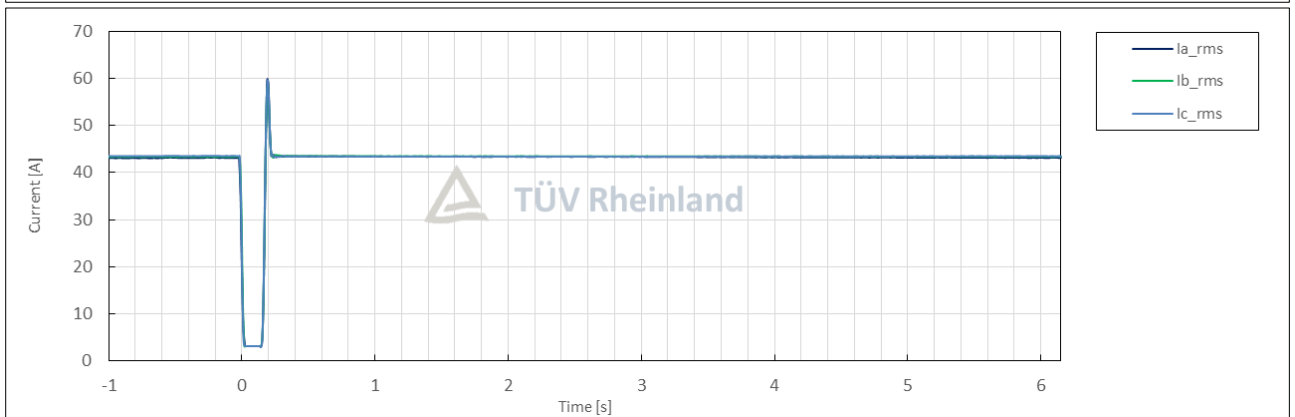
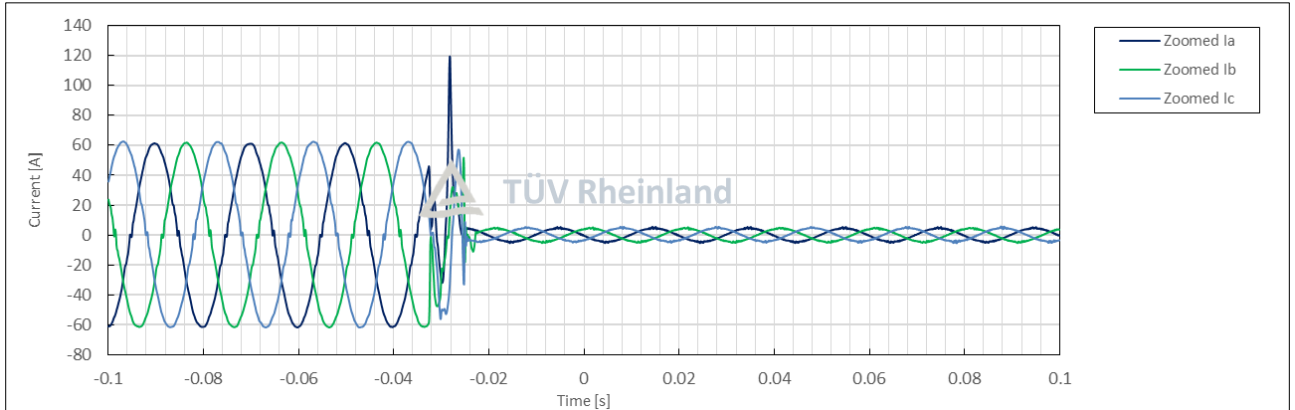

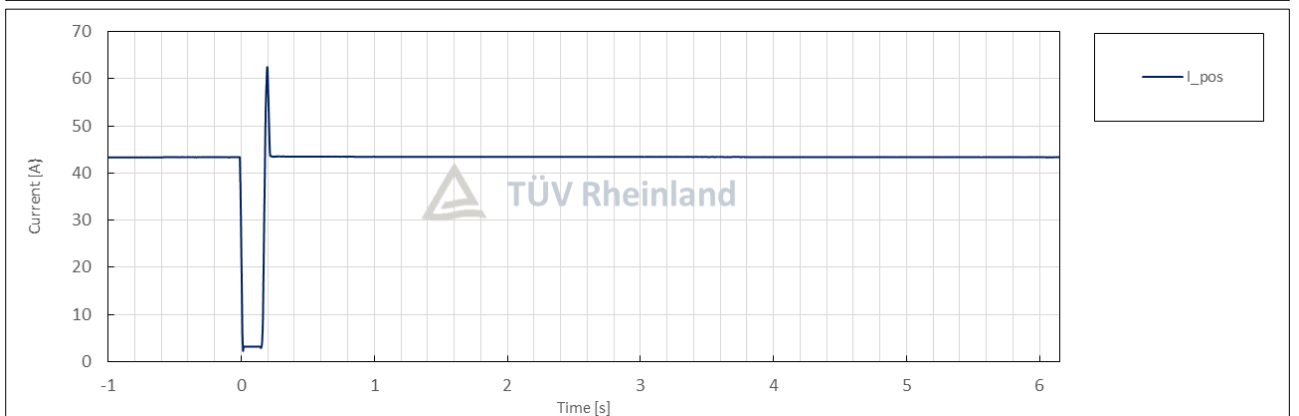
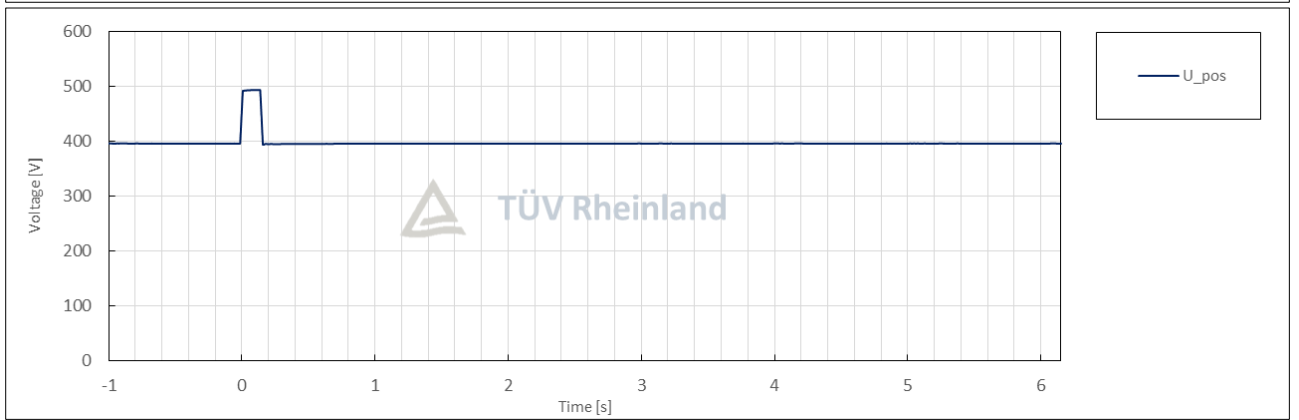
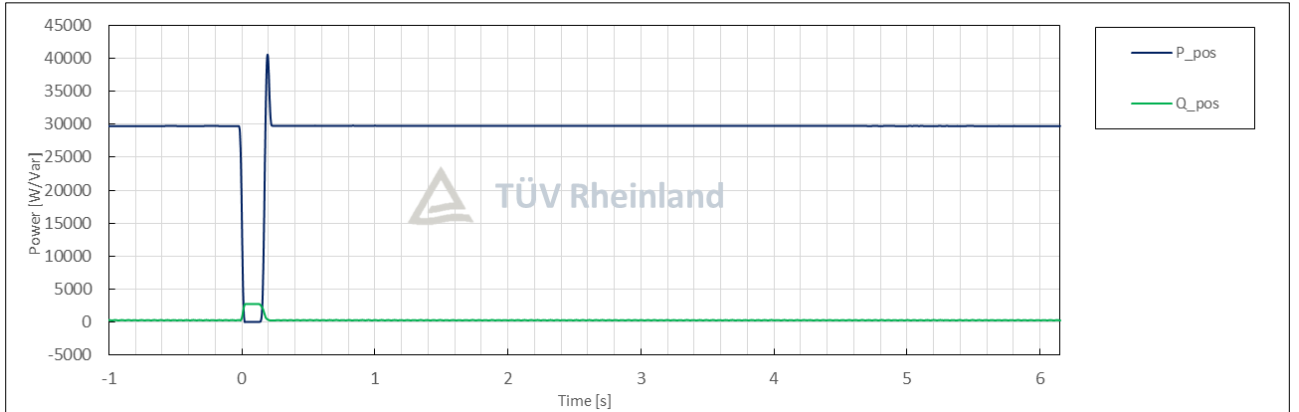

Condition						Measurement
No.	Parameter	Phase ref.	Time ref.	unit		
General Info.	0	Test number	--	--	--	5.3
	1	Date	--	--	dd.mm.yyyy	28.07.2025
	2	Time (start of test)	--	--	hh:mm:ss.f	13:53:15
	3	Fault type (phase)	--	--		2-phase fault
	4	Setting voltage depth	Line to line	--	p.u.	1.25
	5	Setting dip duration		--		140
	6	Point of fault entry	Total	--	ms	0
	7	Point of fault clearance	Total	--	ms	140
	8	Fault duration in empty load test	Total	--	ms	140
	9	Voltage depth/height in empty load test	Total	t1+100ms to t2 and t1-10s to t1	p.u.	1.25
	10		Pos.		p.u.	1.14
Before dip <t1	11	Voltage	Line to neutral	t1-100s to t1	p.u.	1.00
	12	Current	Pos.	t1-500ms to t1-100ms	p.u.	0.99
	13	Active power	Total	t1-10s to t1	p.u.	0.99
	14		Pos.			0.99
	15	Reactive power	Total	t1-10s to t1	p.u.	0.01
	16		Pos.			0.01
	17	Cos ϕ	--	t1-10s to t1	--	1.000
During dip t1 to t2	18	Voltage	Line to neutral	t1+100ms to t2-20ms	p.u.	1.25
	19	Line current	Phase 1	t1+60ms	p.u.	0.02
	20		Phase 2			0.02
	21		Phase 3			0.02
	22	Line current	Phase 1	t1+100ms	p.u.	0.02
	23		Phase 2			0.02
	24		Phase 3			0.02
	25	Active power	Total	t1+100ms to t2-20ms	p.u.	0.00
	26		Pos.			0.00
After dip > t2	27	Voltage	Line to neutral	t2+3s to t2+10s	p.u.	1.00
	28	Active power	Total	t2+3s to t2+10s	p.u.	0.99
	29		Pos.			0.99
	39	Active power rising time	Pos.	--	s	0.035
	31	Reactive power	Total	t2+3s to t2+10s	p.u.	0.01
	32		Pos.			0.01
	33	Reactive power rising time	Pos.	--	s	N/A
	34	PGU does not disconnect from grid till 60s after fault	--	t2 to t2+60s	Yes / No	No

Test No. 5.3 idle test

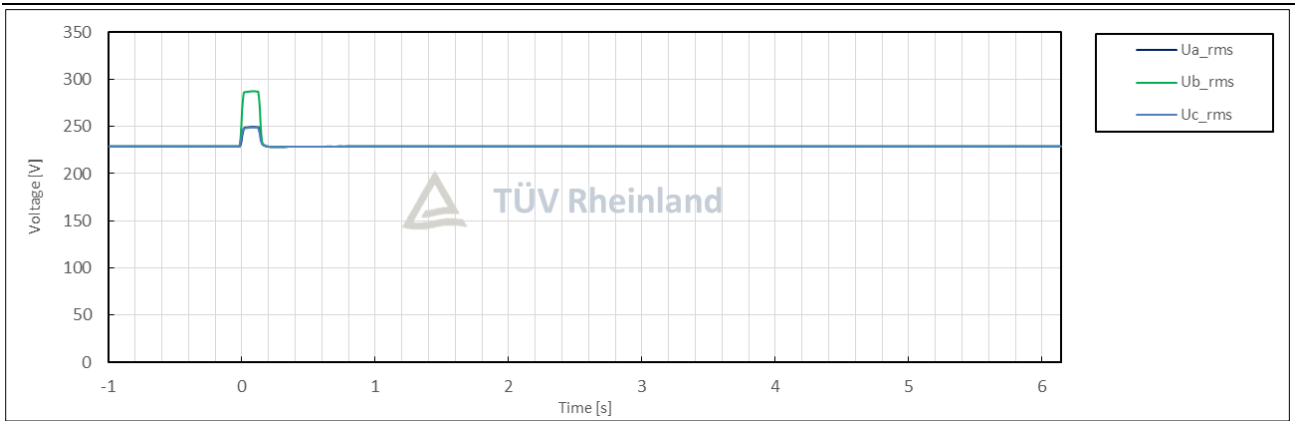
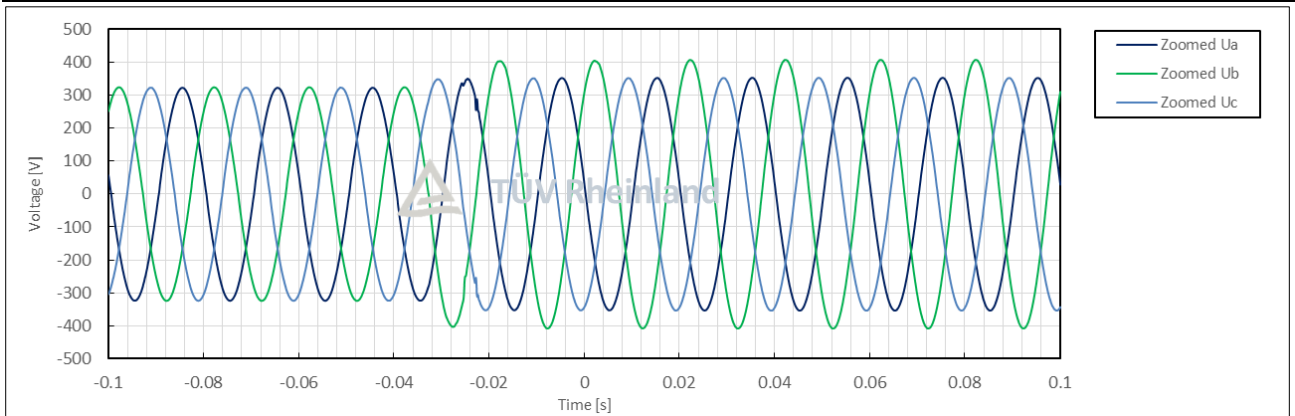
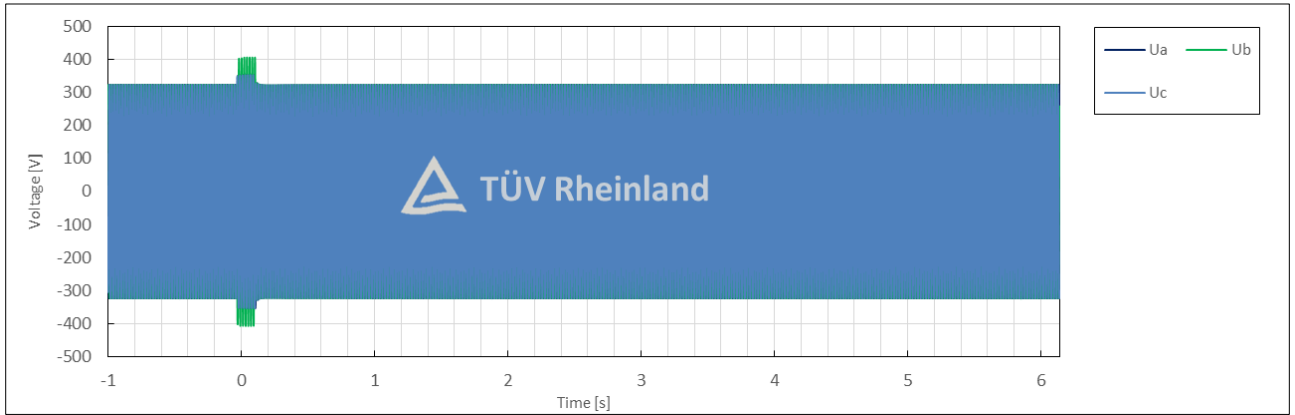

Test No. 5.3 with PGU

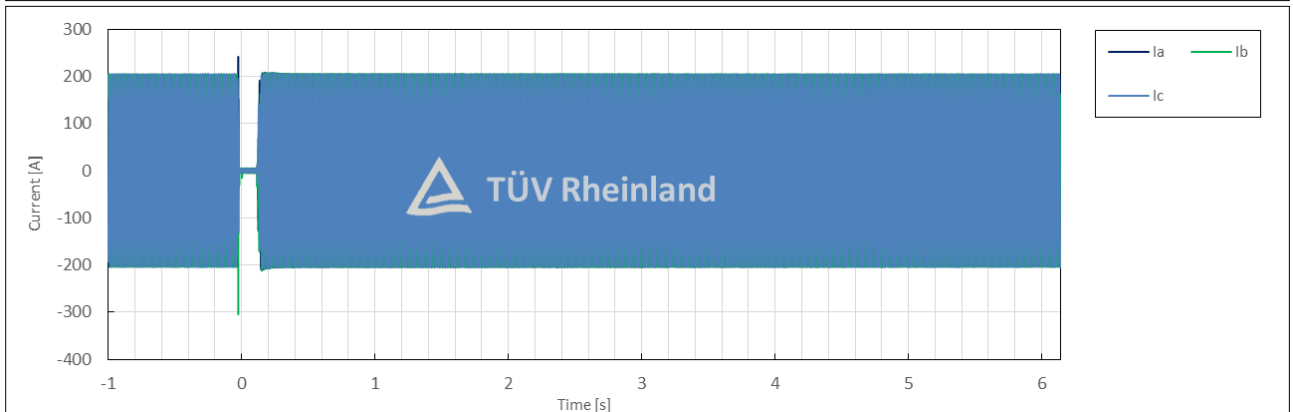
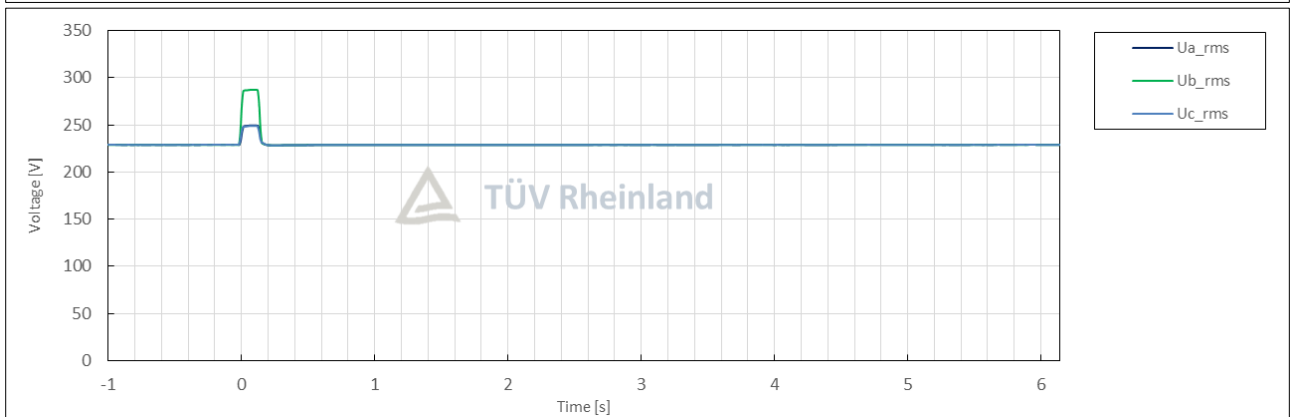
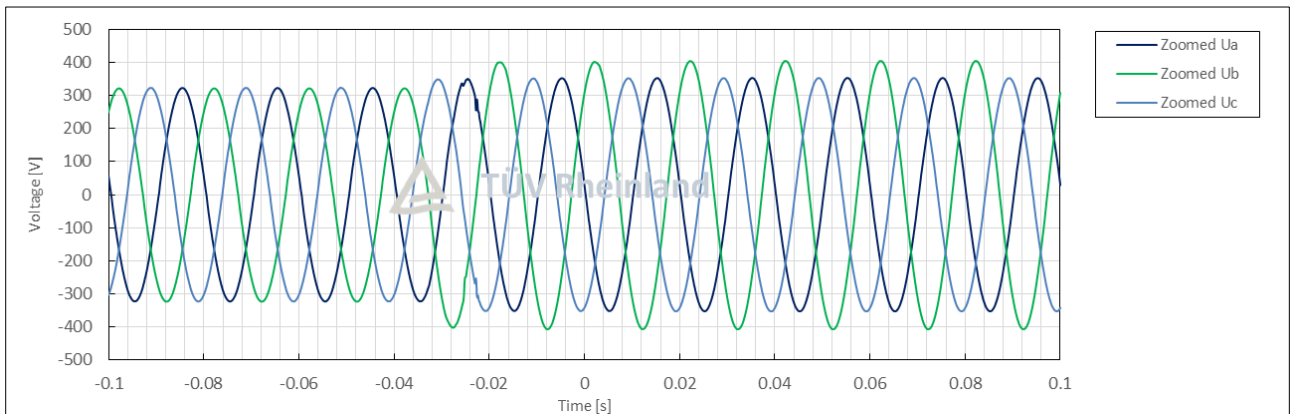
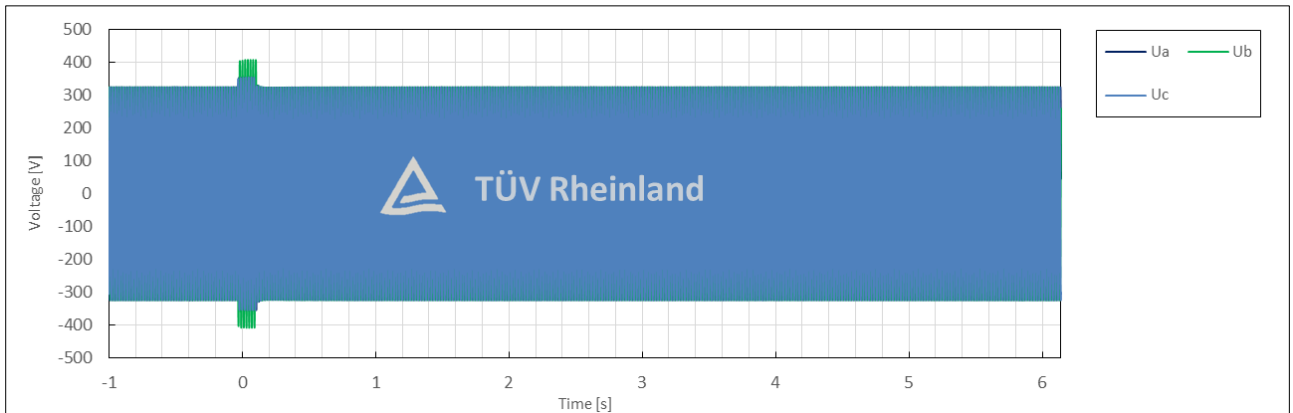

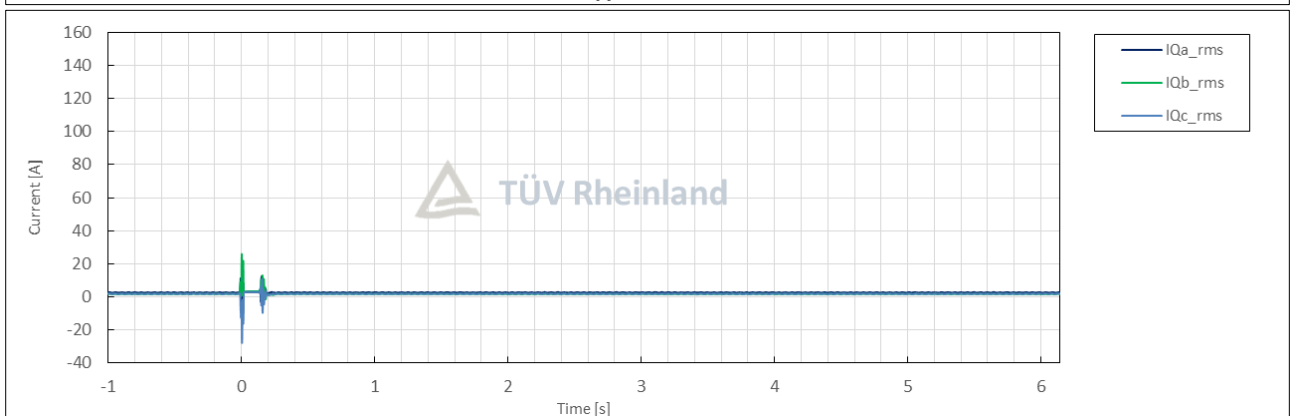
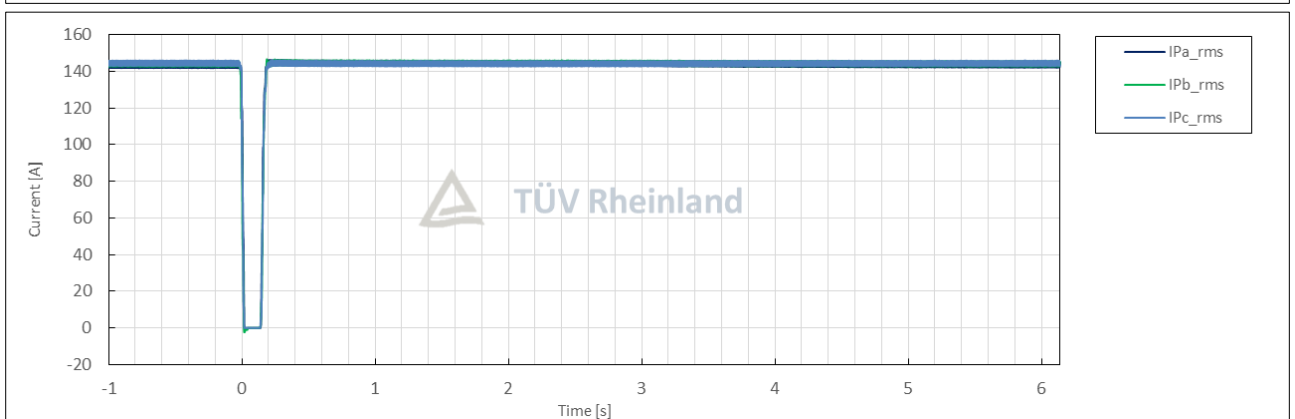
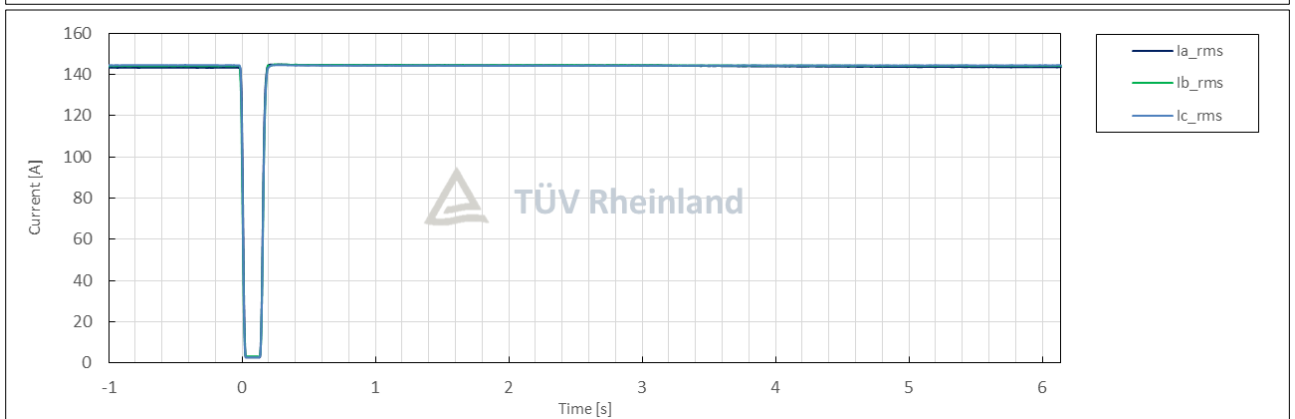
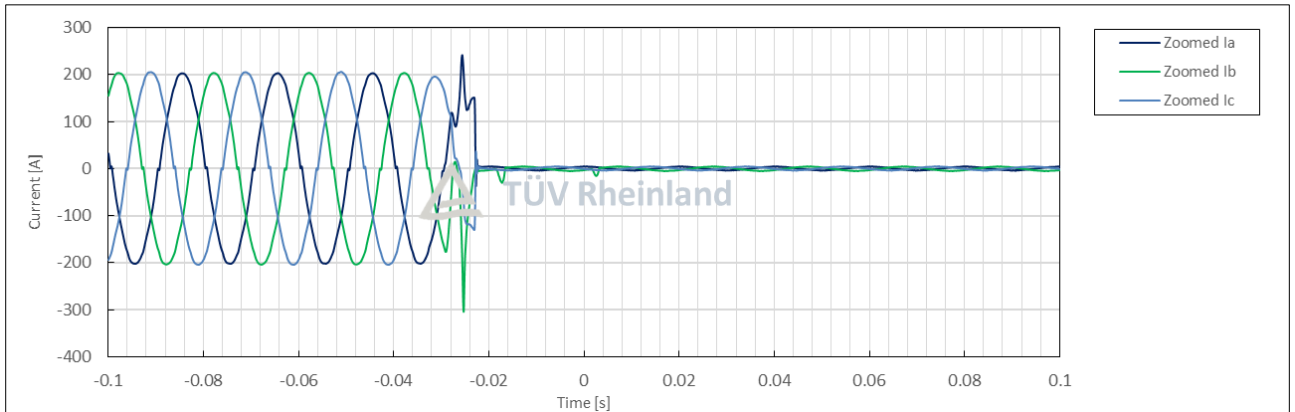

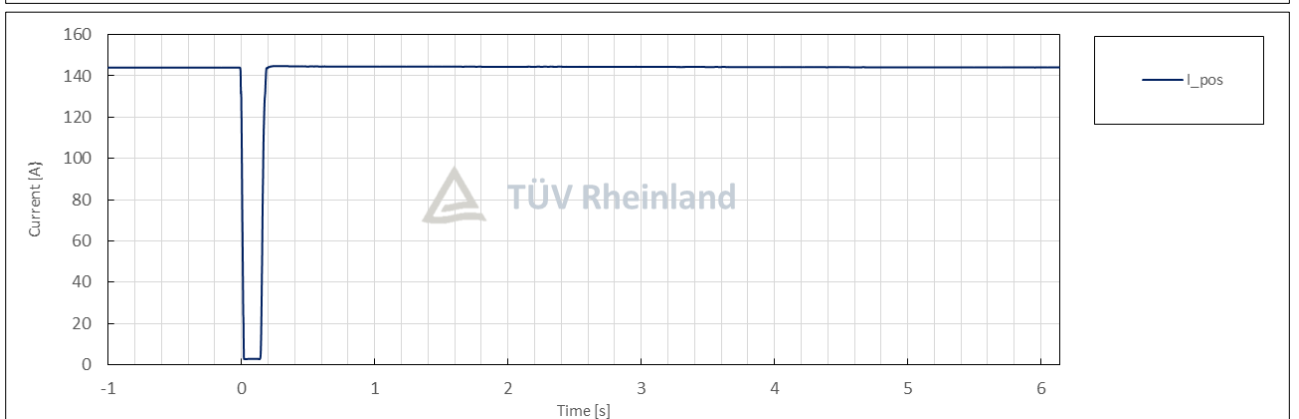
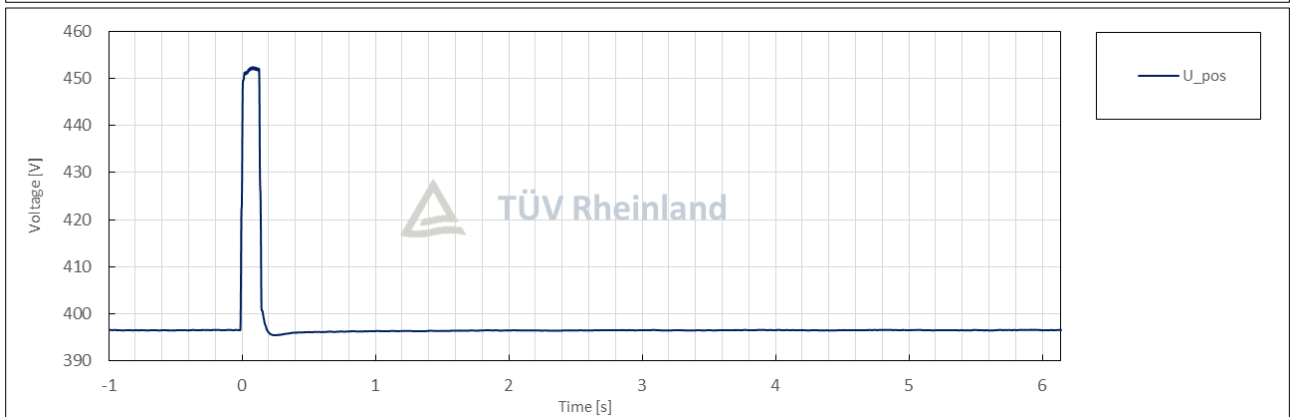
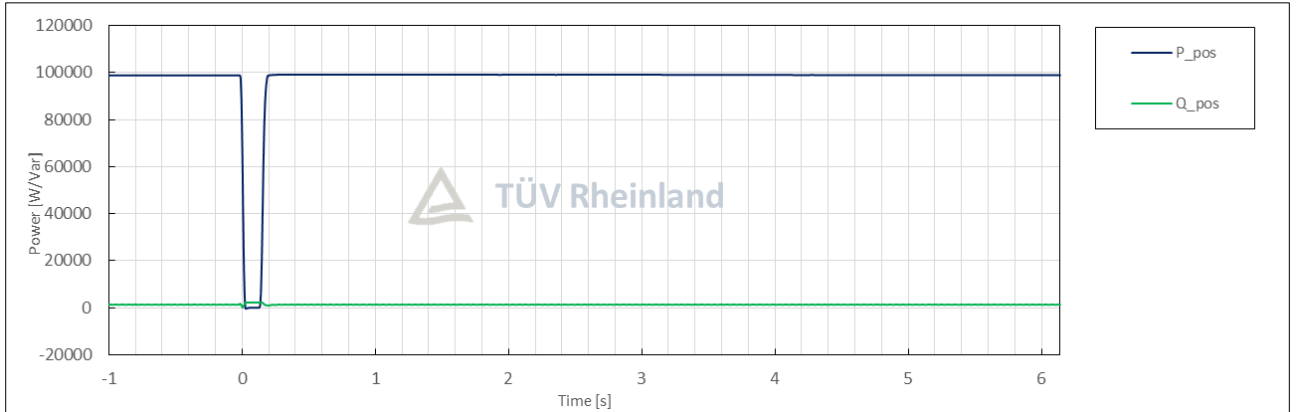

Condition						Measurement
No.	Parameter	Phase ref.	Time ref.	unit		
General Info.	0	Test number	--	--	--	5.3(D2)
	1	Date	--	--	dd.mm.yyyy	28.07.2025
	2	Time (start of test)	--	--	hh:mm:ss.f	13:53:06
	3	Fault type (phase)	--	--		2-phase fault
	4	Setting voltage depth	Line to line	--	p.u.	1.25
	5	Setting dip duration		--		140
	6	Point of fault entry	Total	--	ms	0
	7	Point of fault clearance	Total	--	ms	140
	8	Fault duration in empty load test	Total	--	ms	140
	9	Voltage depth/height in empty load test	Total	t1+100ms to t2 and t1-10s to t1	p.u.	1.25
10	Pos.		p.u.		1.14	
Before dip <t1	11	Voltage	Line to neutral	t1-100s to t1	p.u.	1.00
	12	Current	Pos.	t1-500ms to t1-100ms	p.u.	0.99
	13	Active power	Total	t1-10s to t1	p.u.	0.99
	14		Pos.			0.99
	15	Reactive power	Total	t1-10s to t1	p.u.	0.01
	16		Pos.			0.01
17	Cos ϕ	--	t1-10s to t1	--	1.000	
During dip t1 to t2	18	Voltage	Line to neutral	t1+100ms to t2-20ms	p.u.	1.25
	19	Line current	Phase 1	t1+60ms	p.u.	0.02
	20		Phase 2			0.02
	21		Phase 3			0.02
	22	Line current	Phase 1	t1+100ms	p.u.	0.02
	23		Phase 2			0.02
	24		Phase 3			0.02
	25	Active power	Total	t1+100ms to t2-20ms	p.u.	0.00
26	Pos.		0.00			
After dip > t2	27	Voltage	Line to neutral	t2+3s to t2+10s	p.u.	1.00
	28	Active power	Total	t2+3s to t2+10s	p.u.	0.99
	29		Pos.			0.99
	39	Active power rising time	Pos.	--	s	0.038
	31	Reactive power	Total	t2+3s to t2+10s	p.u.	0.01
	32		Pos.			0.01
	33	Reactive power rising time	Pos.	--	s	N/A
34	PGU does not disconnect from grid till 60s after fault	--	t2 to t2+60s	Yes / No	No	

Test No. 5.3(D2) idle test

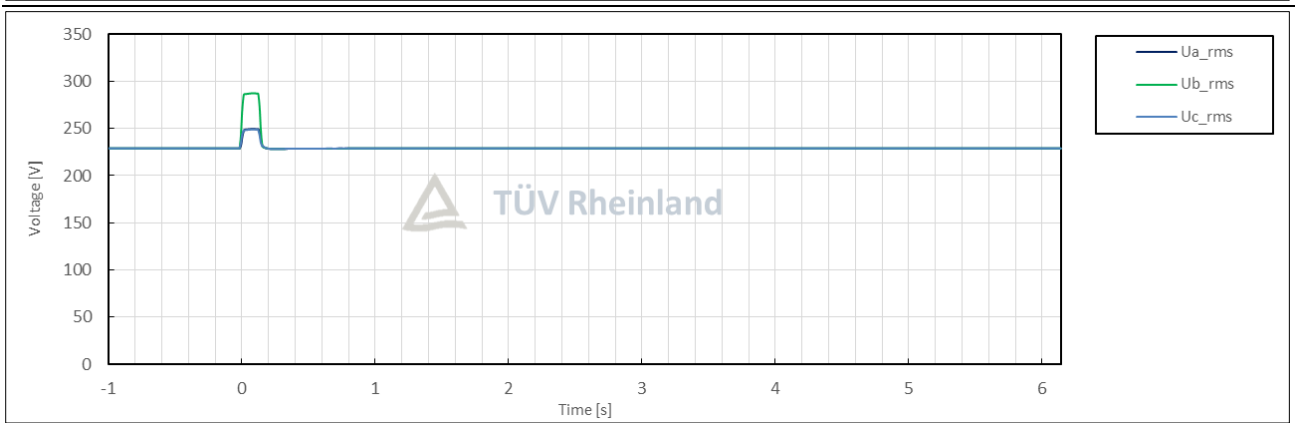
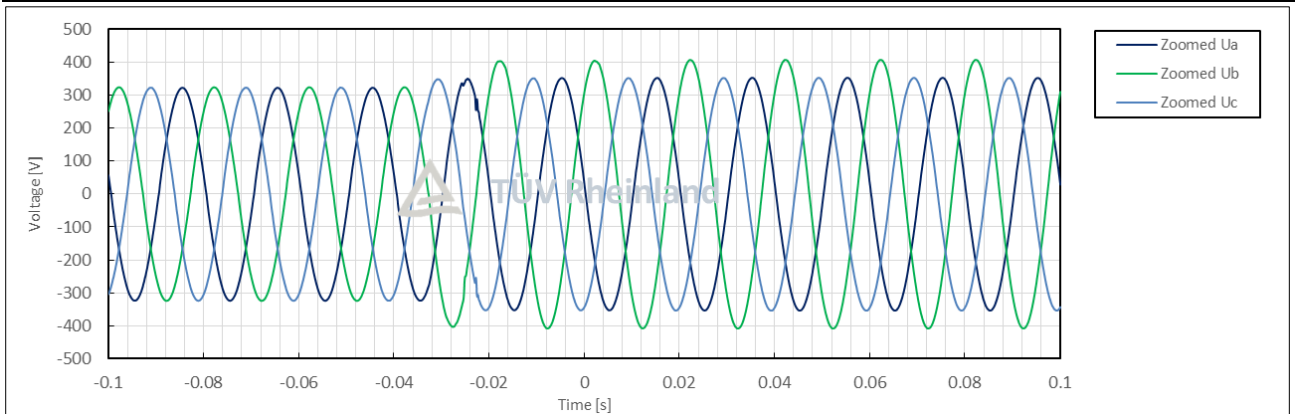
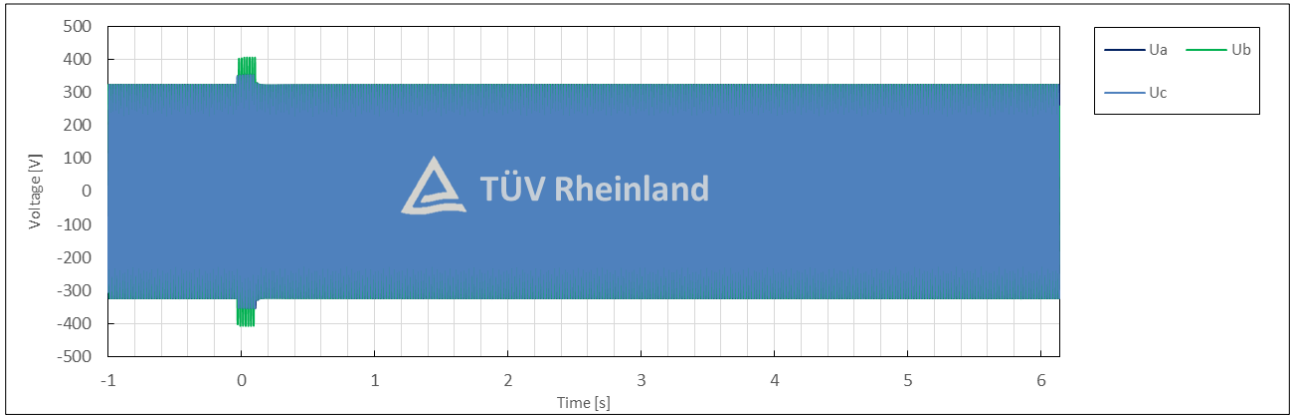

Test No. 5.3(D2) with PGU

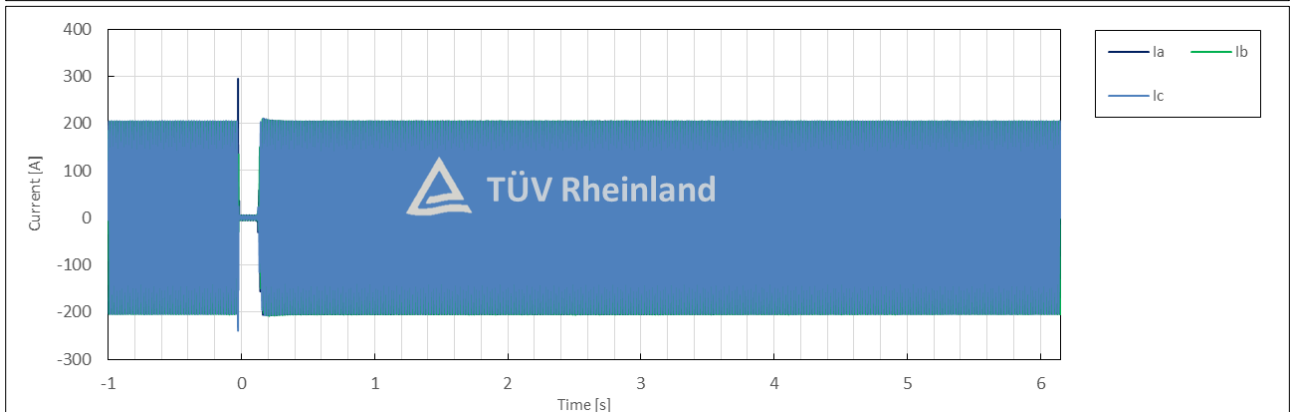
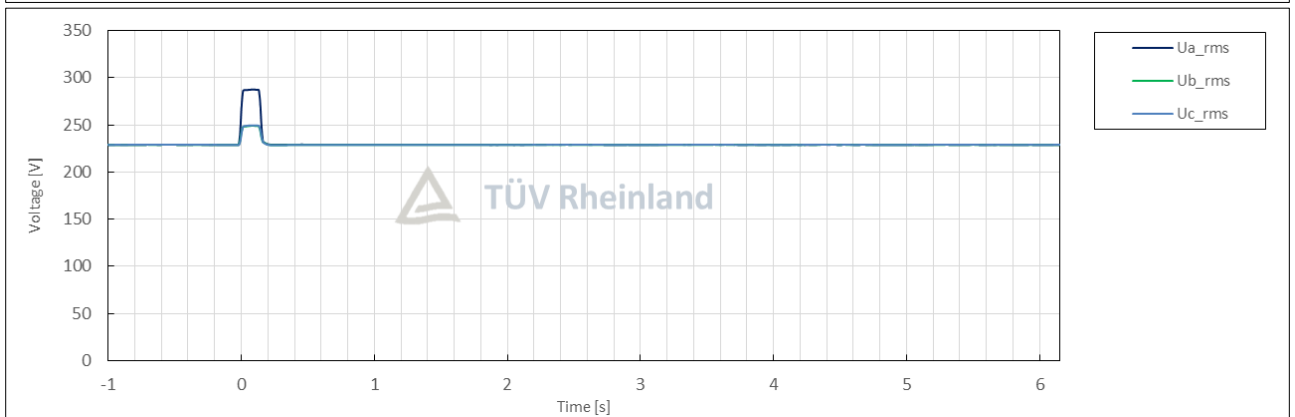
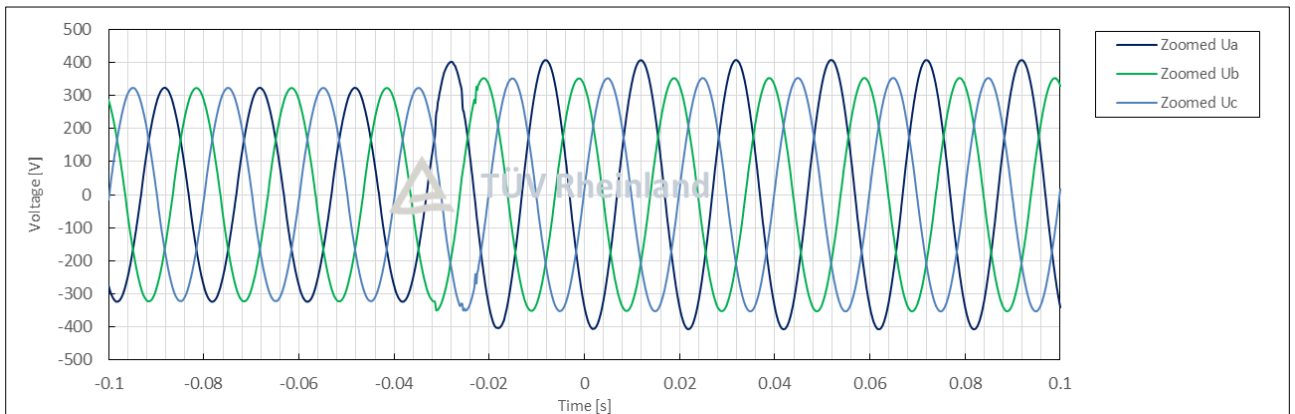
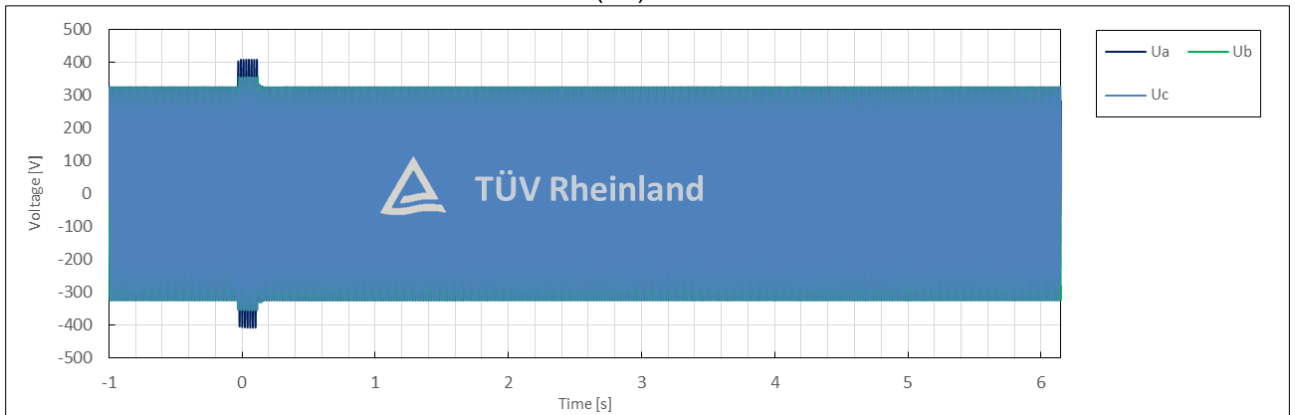

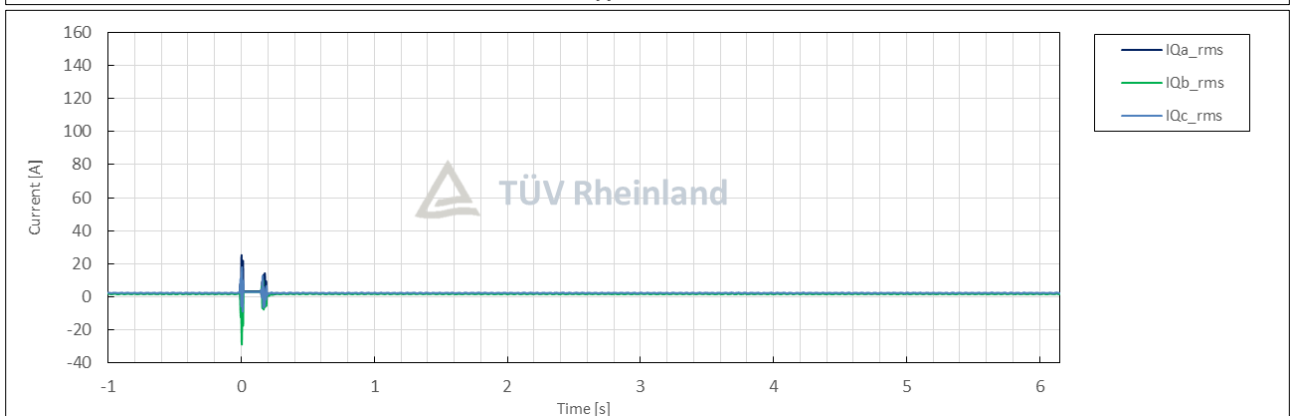
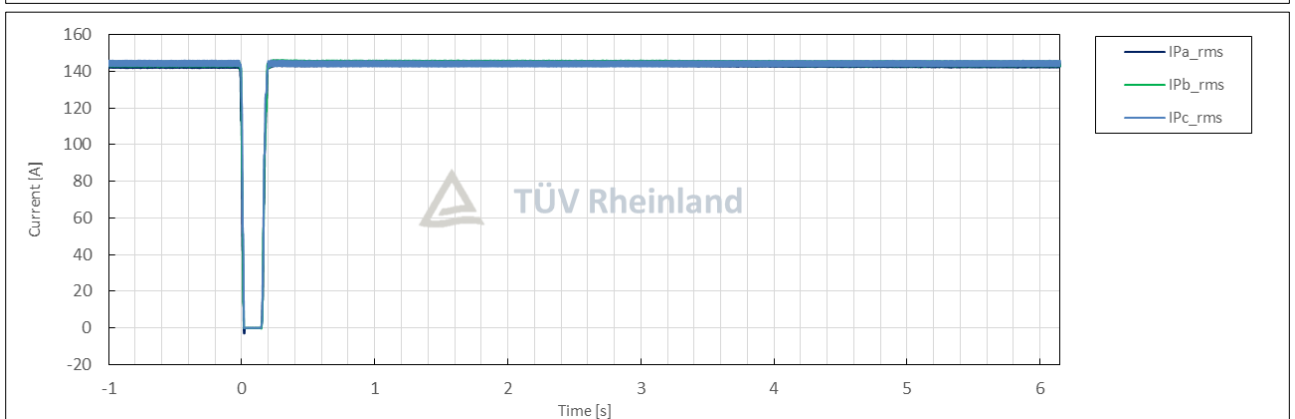
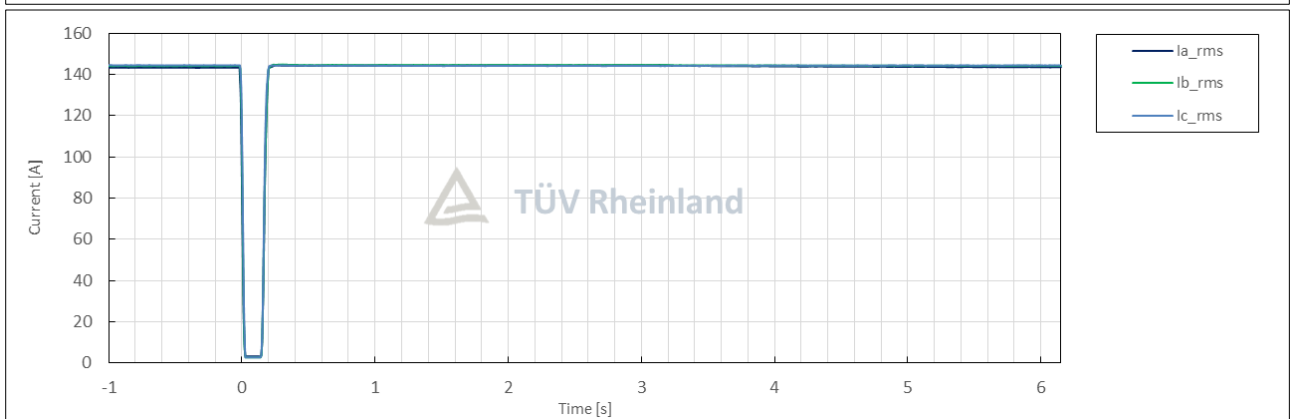
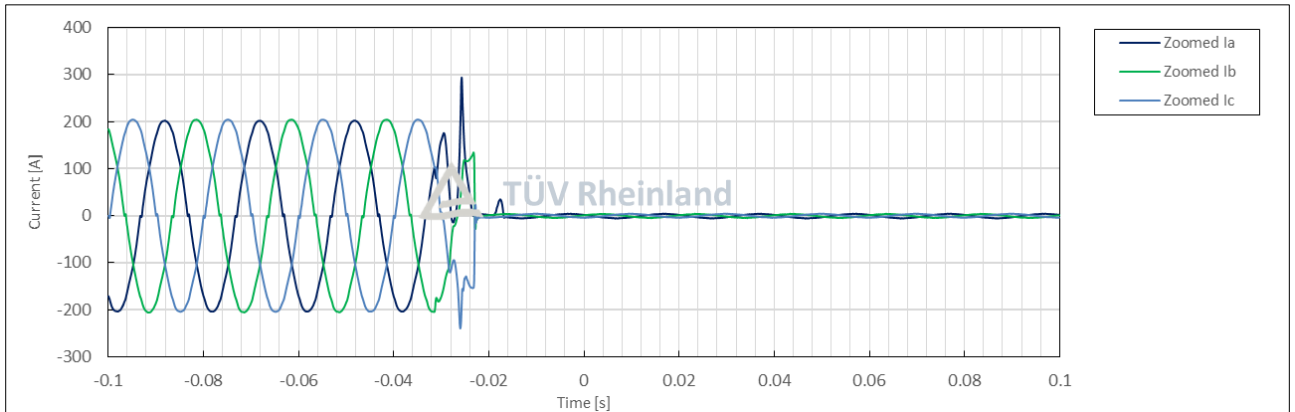

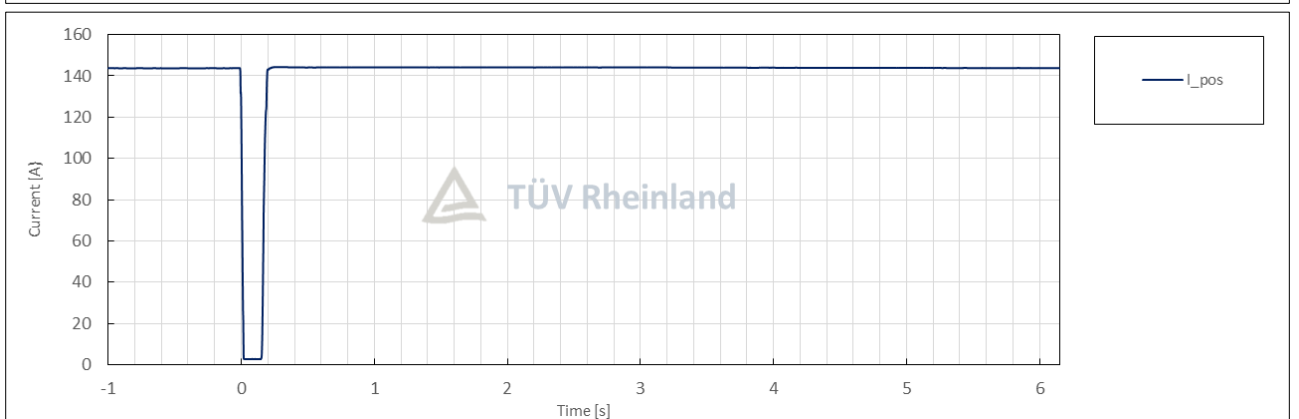
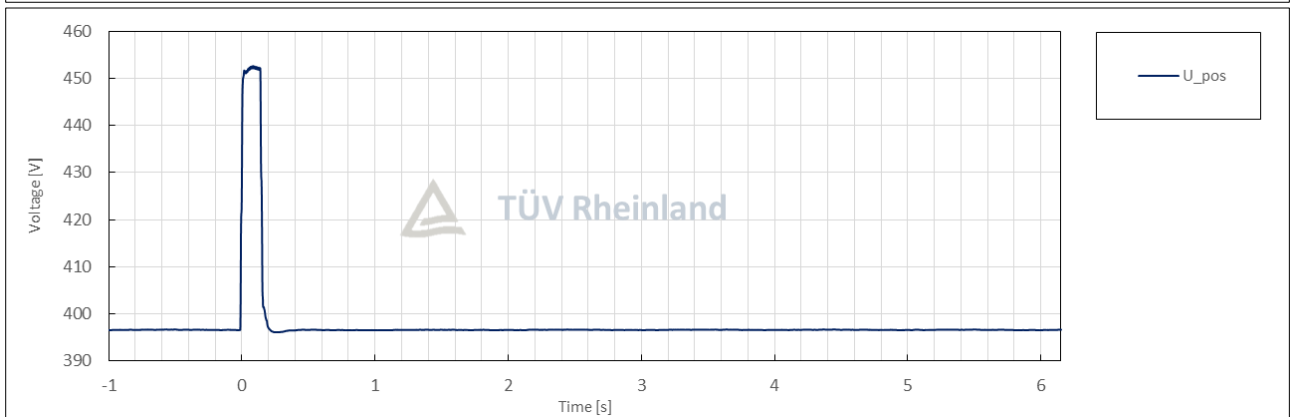
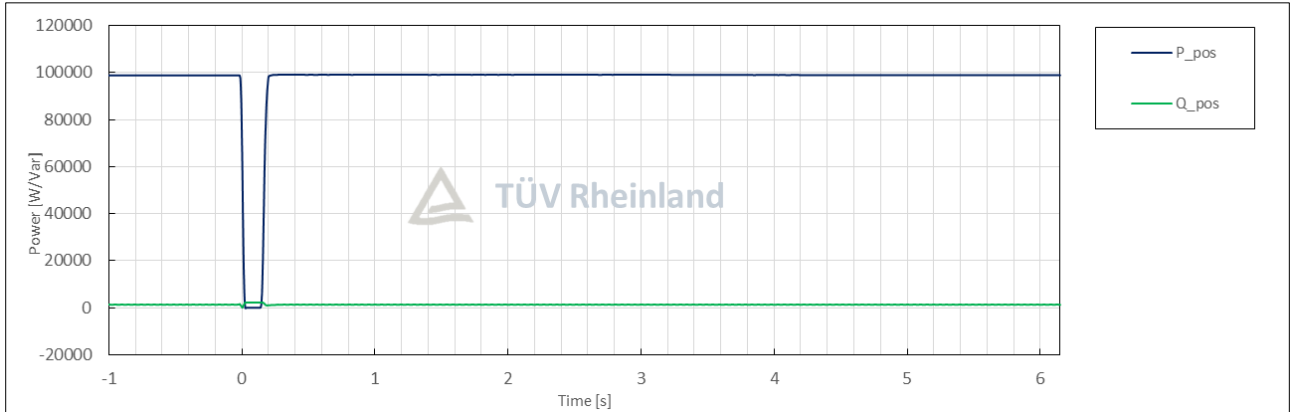

Condition						Measurement
No.	Parameter	Phase ref.	Time ref.	unit		
General Info.	0	Test number	--	--	--	5.4
	1	Date	--	--	dd.mm.yyyy	28.07.2025
	2	Time (start of test)	--	--	hh:mm:ss.f	13:53:29
	3	Fault type (phase)	--	--		2-phase fault
	4	Setting voltage depth	Line to line	--	p.u.	1.25
	5	Setting dip duration		--		140
	6	Point of fault entry	Total	--	ms	0
	7	Point of fault clearance	Total	--	ms	140
	8	Fault duration in empty load test	Total	--	ms	140
	9	Voltage depth/height in empty load test	Total	t1+100ms to t2 and t1-10s to t1	p.u.	1.25
10	Pos.		p.u.		1.14	
Before dip <t1	11	Voltage	Line to neutral	t1-100s to t1	p.u.	1.00
	12	Current	Pos.	t1-500ms to t1-100ms	p.u.	0.30
	13	Active power	Total	t1-10s to t1	p.u.	0.30
	14		Pos.			0.30
	15	Reactive power	Total	t1-10s to t1	p.u.	0.00
	16		Pos.			0.00
	17	Cos ϕ	--	t1-10s to t1	--	1.000
During dip t1 to t2	18	Voltage	Line to neutral	t1+100ms to t2-20ms	p.u.	1.24
	19	Line current	Phase 1	t1+60ms	p.u.	0.02
	20		Phase 2			0.02
	21		Phase 3			0.02
	22	Line current	Phase 1	t1+100ms	p.u.	0.02
	23		Phase 2			0.02
	24		Phase 3			0.02
	25	Active power	Total	t1+100ms to t2-20ms	p.u.	0.00
26	Pos.		0.00			
After dip > t2	27	Voltage	Line to neutral	t2+3s to t2+10s	p.u.	0.99
	28	Active power	Total	t2+3s to t2+10s	p.u.	0.30
	29		Pos.			0.30
	39	Active power rising time	Pos.	--	s	0.024
	31	Reactive power	Total	t2+3s to t2+10s	p.u.	0.00
	32		Pos.			0.00
	33	Reactive power rising time	Pos.	--	s	N/A
	34	PGU does not disconnect from grid till 60s after fault	--	t2 to t2+60s	Yes / No	No

Test No. 5.4 idle test

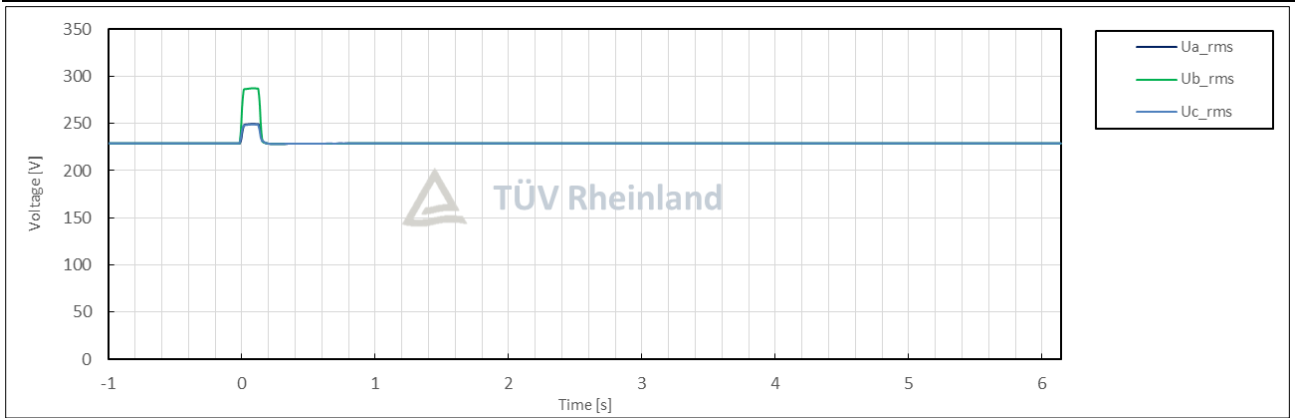
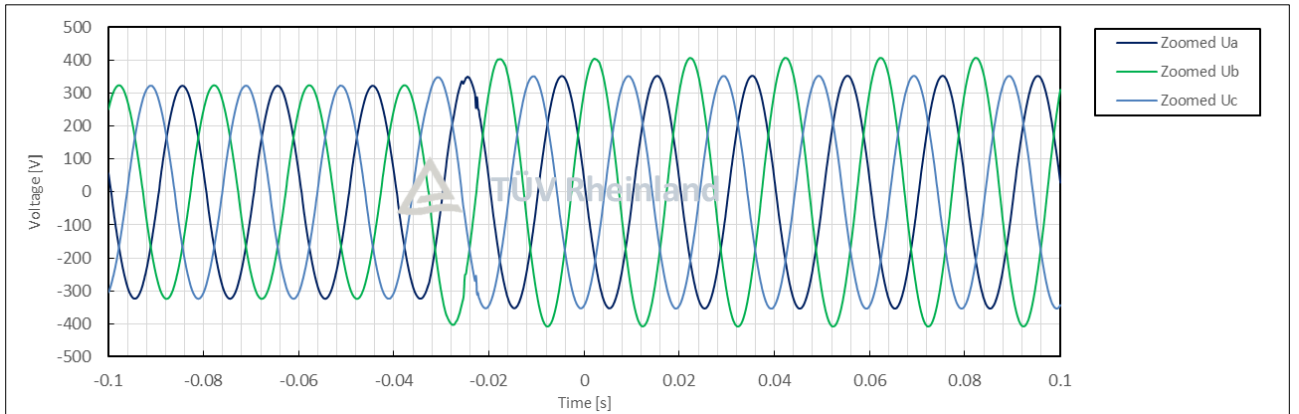
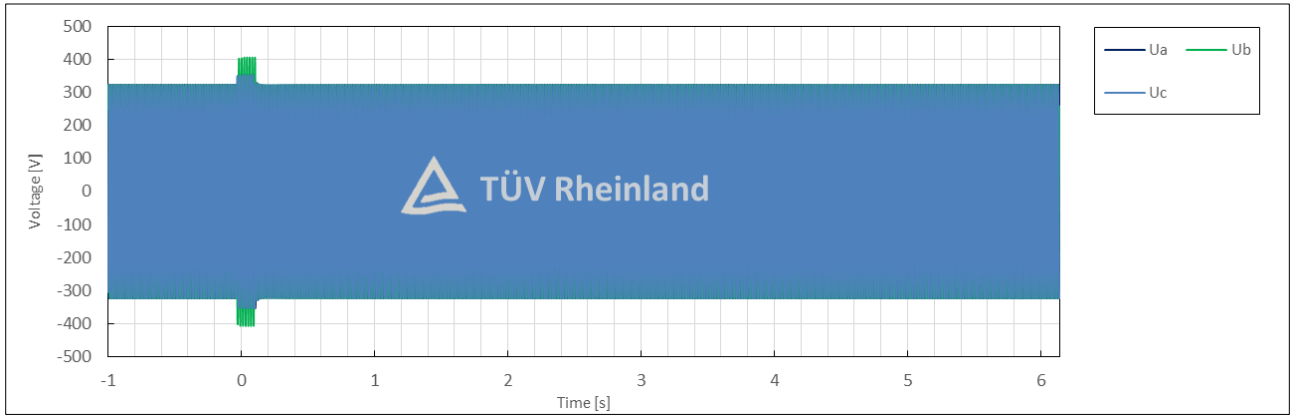

Test No. 5.4 with PGU

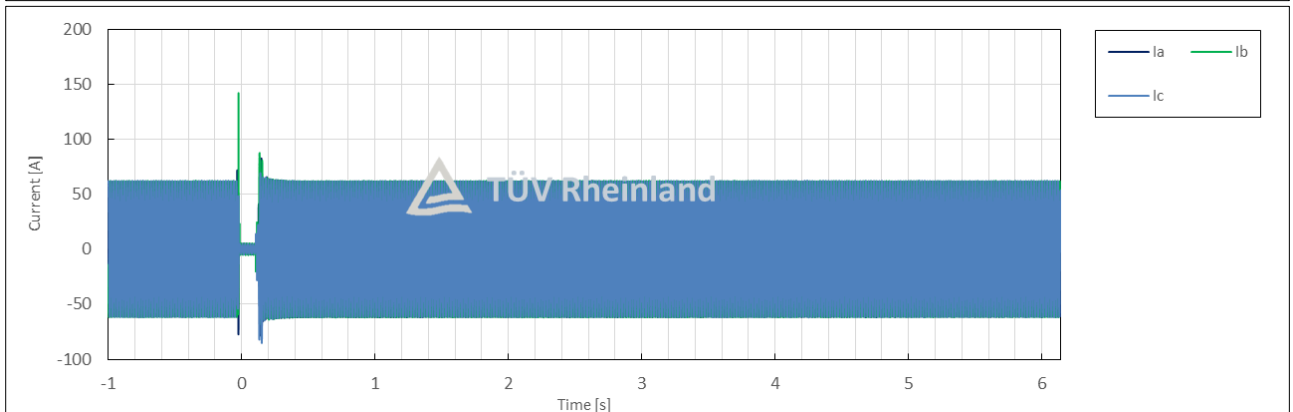
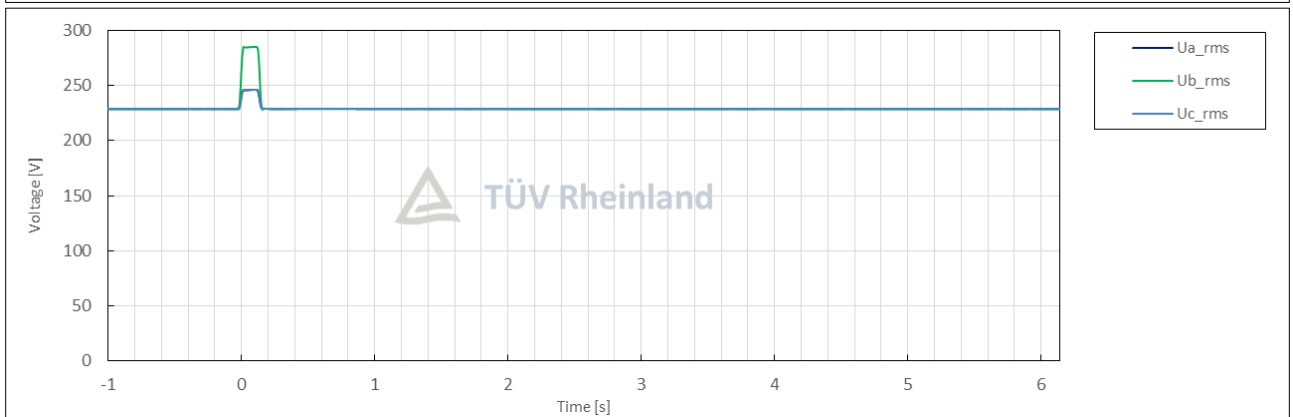
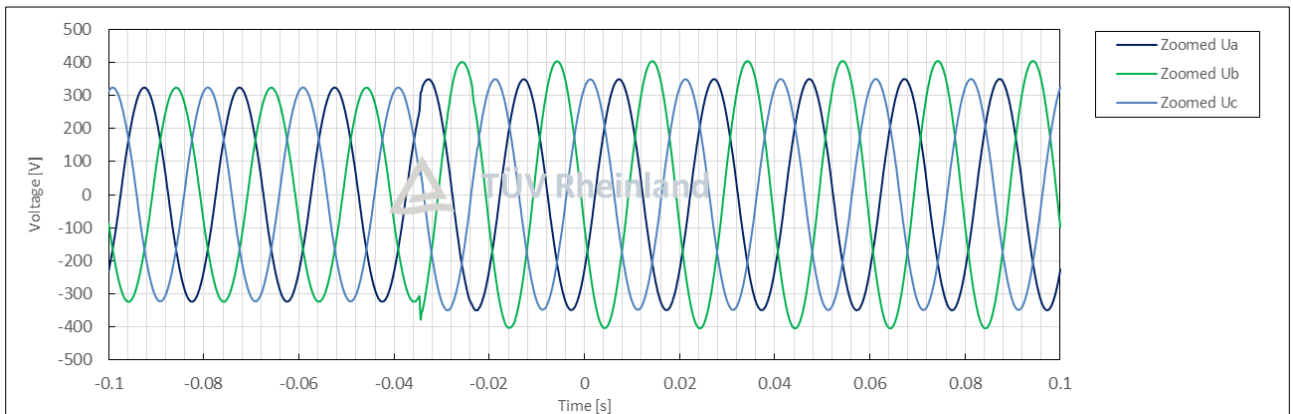
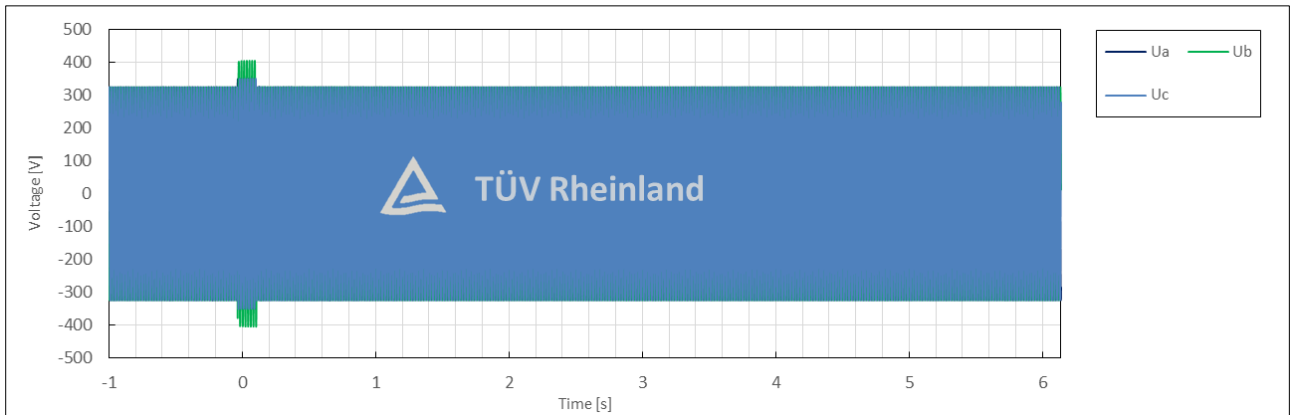

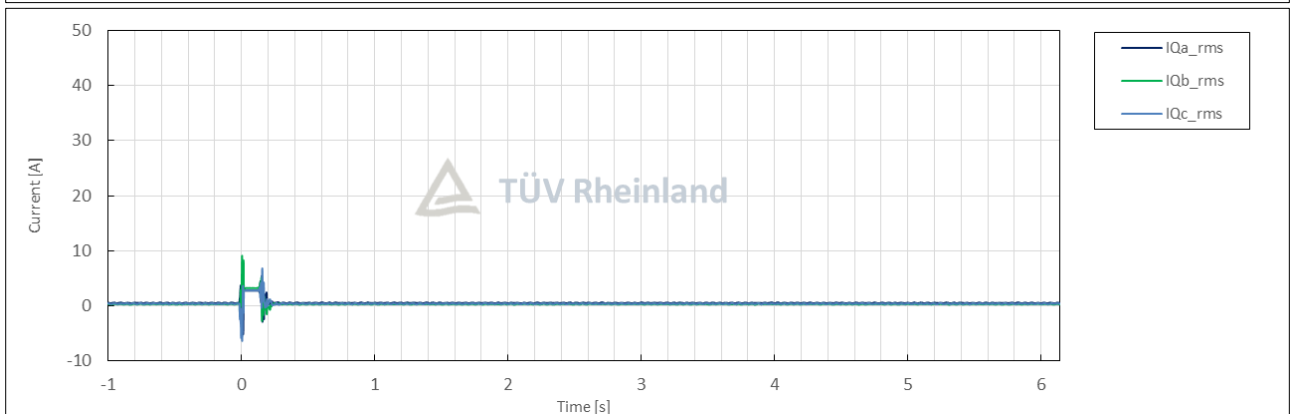
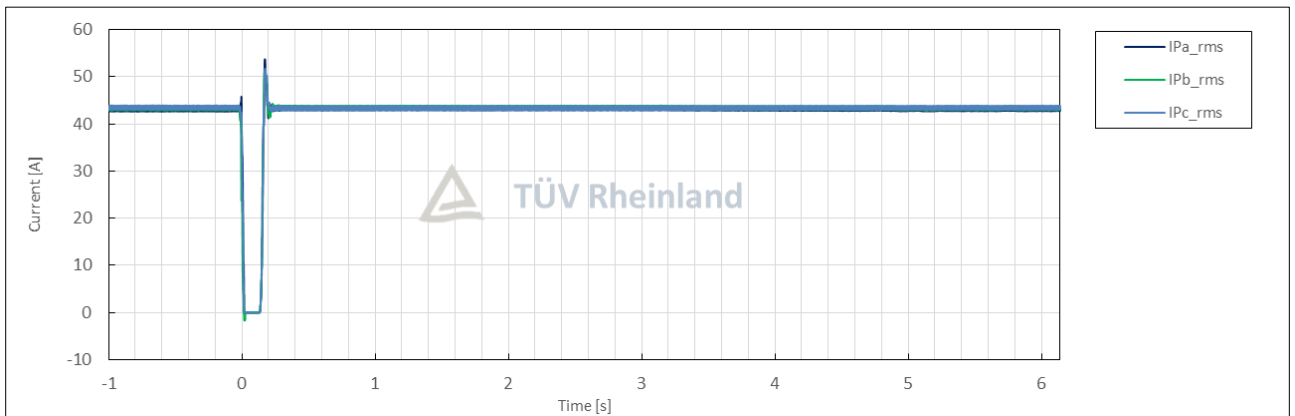
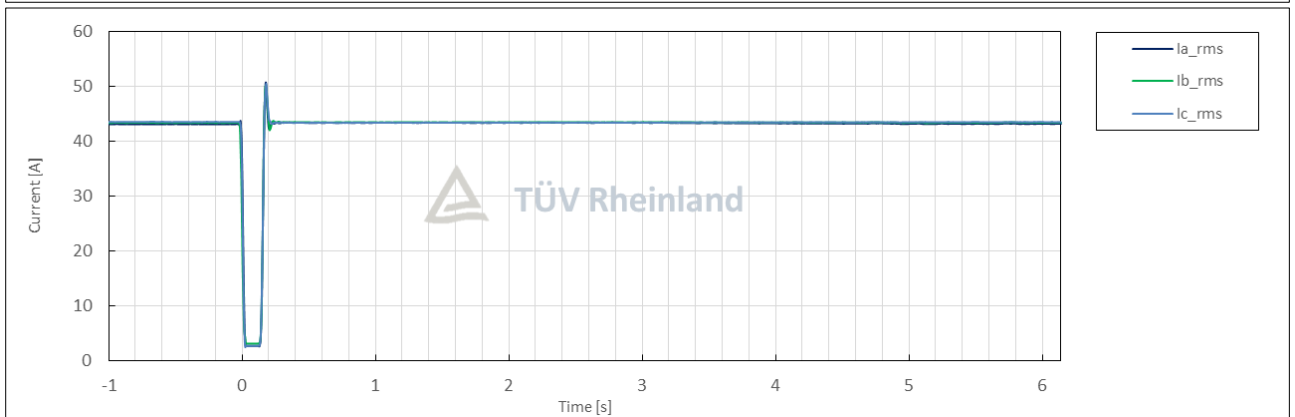
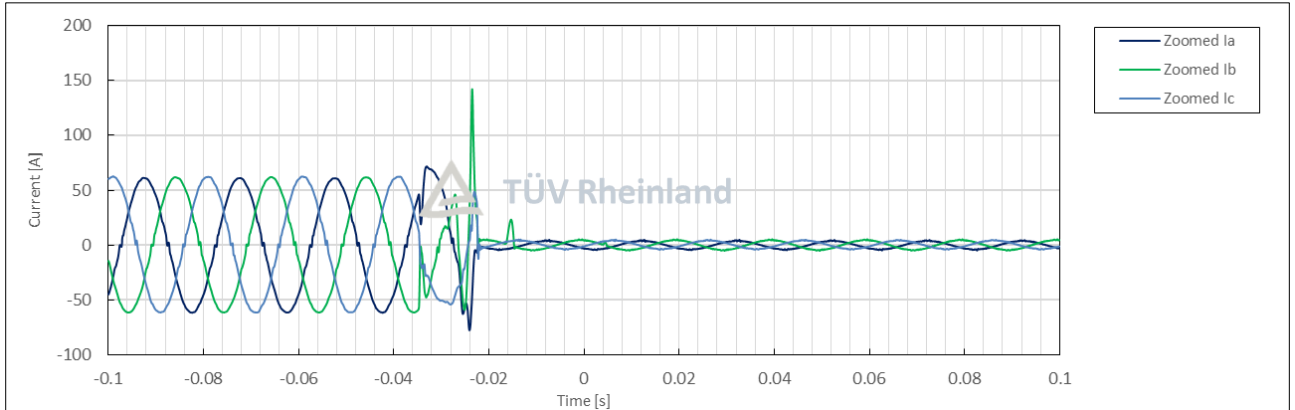

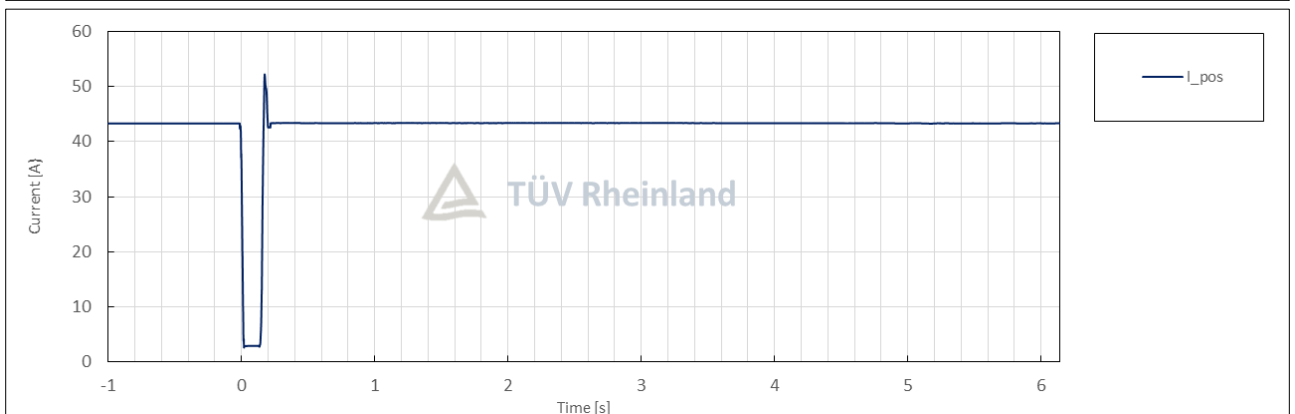
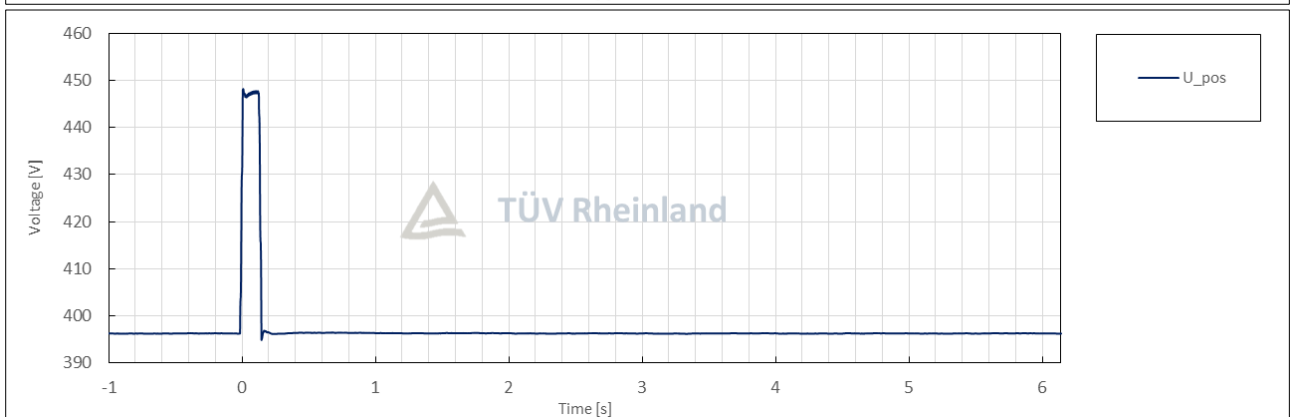
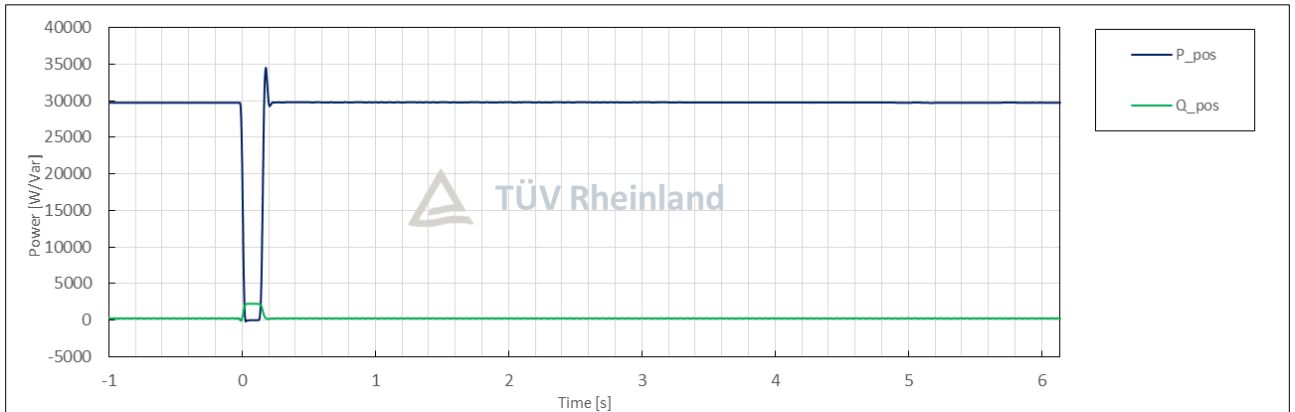

Condition						Measurement
No.	Parameter	Phase ref.	Time ref.	unit		
General Info.	0	Test number	--	--	--	6.1
	1	Date	--	--	dd.mm.yyyy	28.07.2025
	2	Time (start of test)	--	--	hh:mm:ss.f	13:53:54
	3	Fault type (phase)	--	--		3-phase fault
	4	Setting voltage depth	Line to line	--	p.u.	1.20
	5	Setting dip duration		--		5998
	6	Point of fault entry	Total	--	ms	0
	7	Point of fault clearance	Total	--	ms	5998
	8	Fault duration in empty load test	Total	--	ms	5998
	9	Voltage depth/height in empty load test	Total	t1+100ms to t2 and t1-10s to t1	p.u.	1.20
	10		Pos.		p.u.	1.20
Before dip <t1	11	Voltage	Line to neutral	t1-100s to t1	p.u.	1.00
	12	Current	Pos.	t1-500ms to t1-100ms	p.u.	0.99
	13	Active power	Total	t1-10s to t1	p.u.	0.99
	14		Pos.			0.99
	15	Reactive power	Total	t1-10s to t1	p.u.	0.01
	16		Pos.			0.01
	17	Cos ϕ	--	t1-10s to t1	--	1.000
During dip t1 to t2	18	Voltage	Line to neutral	t1+100ms to t2-20ms	p.u.	1.20
	19	Line current	Phase 1	t1+60ms	p.u.	0.02
	20		Phase 2			0.02
	21		Phase 3			0.02
	22	Line current	Phase 1	t1+100ms	p.u.	0.02
	23		Phase 2			0.02
	24		Phase 3			0.02
	25	Active power	Total	t1+100ms to t2-20ms	p.u.	0.00
	26		Pos.			0.00
After dip > t2	27	Voltage	Line to neutral	t2+3s to t2+10s	p.u.	1.00
	28	Active power	Total	t2+3s to t2+10s	p.u.	0.99
	29		Pos.			0.99
	39	Active power rising time	Pos.	--	s	0.059
	31	Reactive power	Total	t2+3s to t2+10s	p.u.	0.01
	32		Pos.			0.01
	33	Reactive power rising time	Pos.	--	s	N/A
	34	PGU does not disconnect from grid till 60s after fault	--	t2 to t2+60s	Yes / No	No

Test No. 6.1 idle test

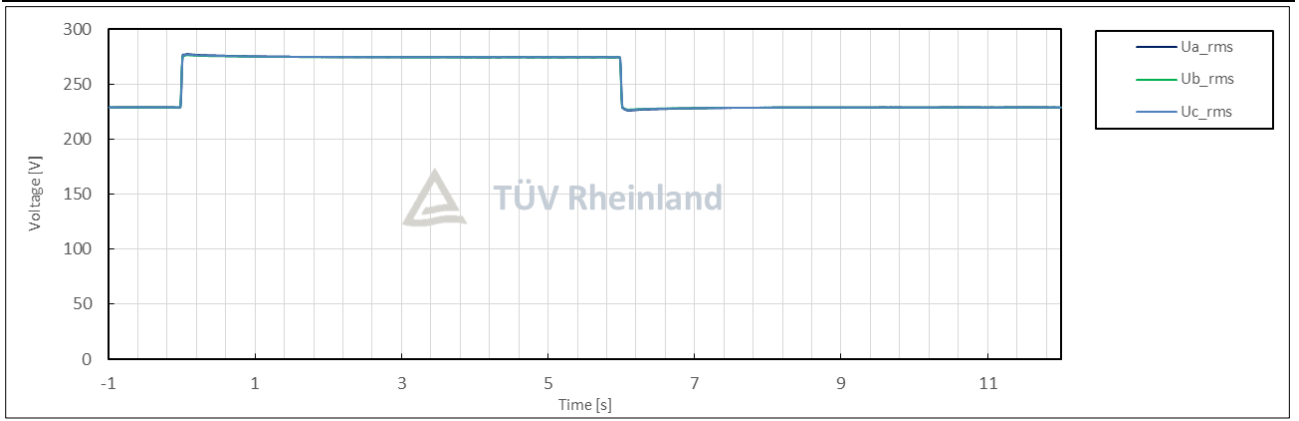
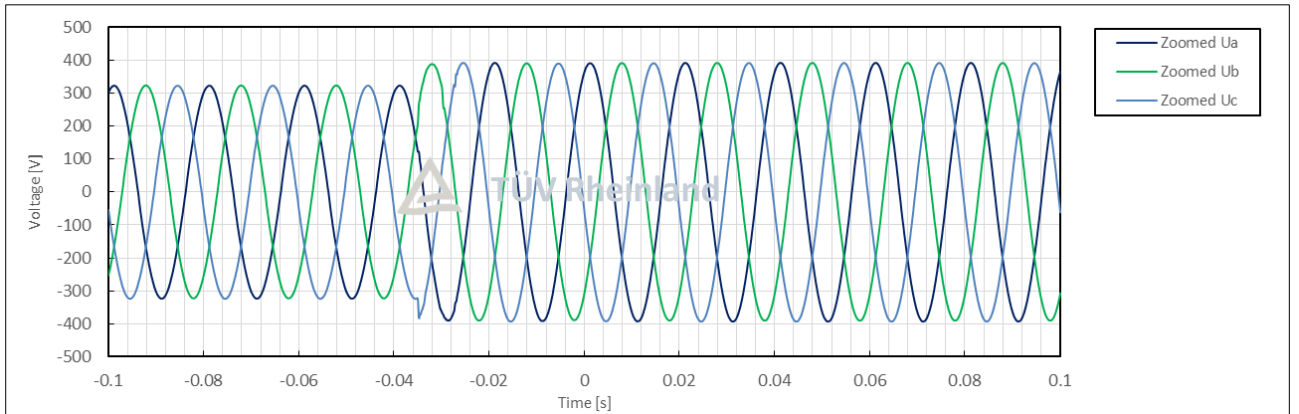
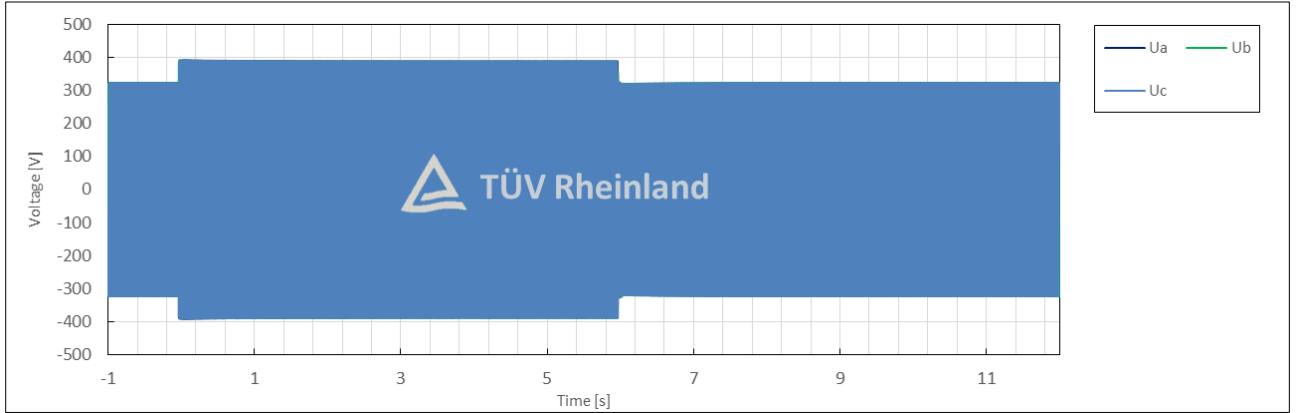

Test No. 6.1 with PGU

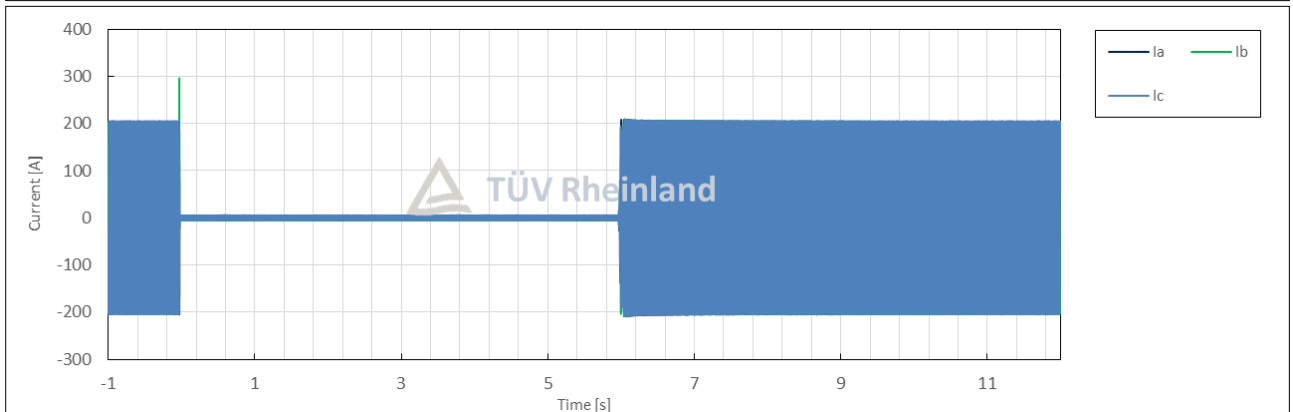
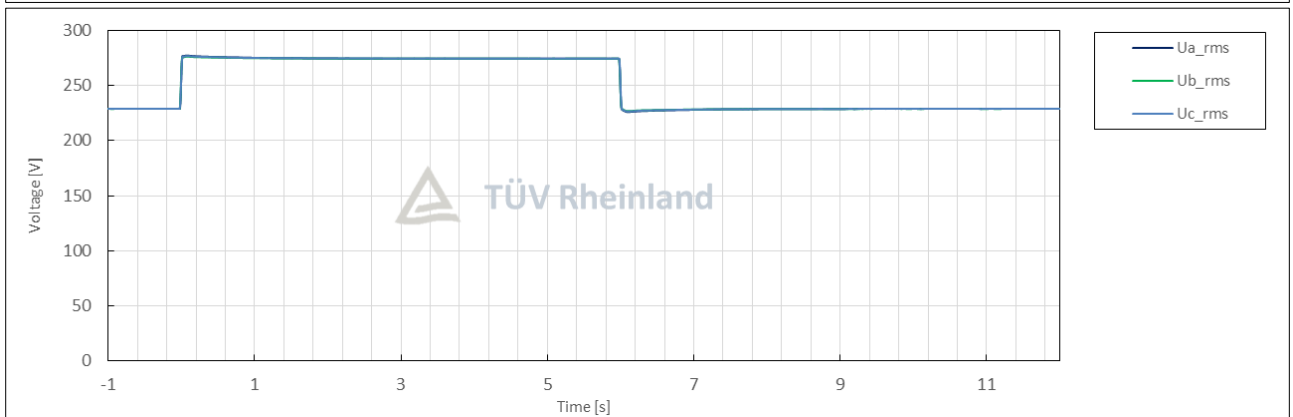
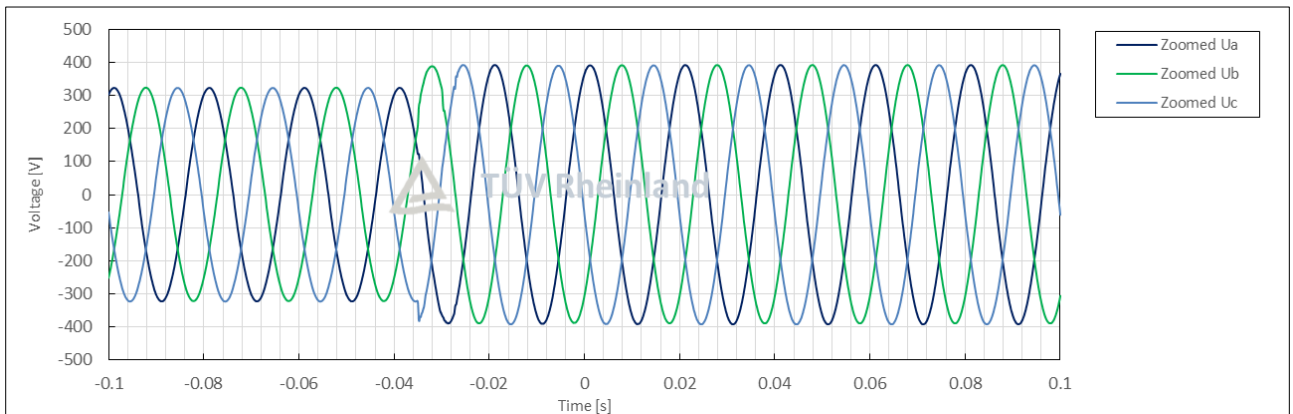
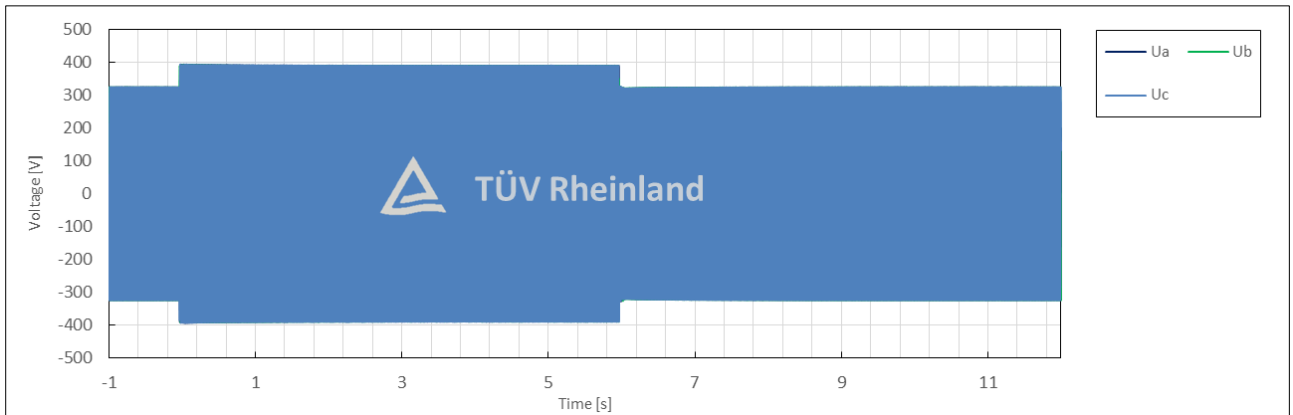

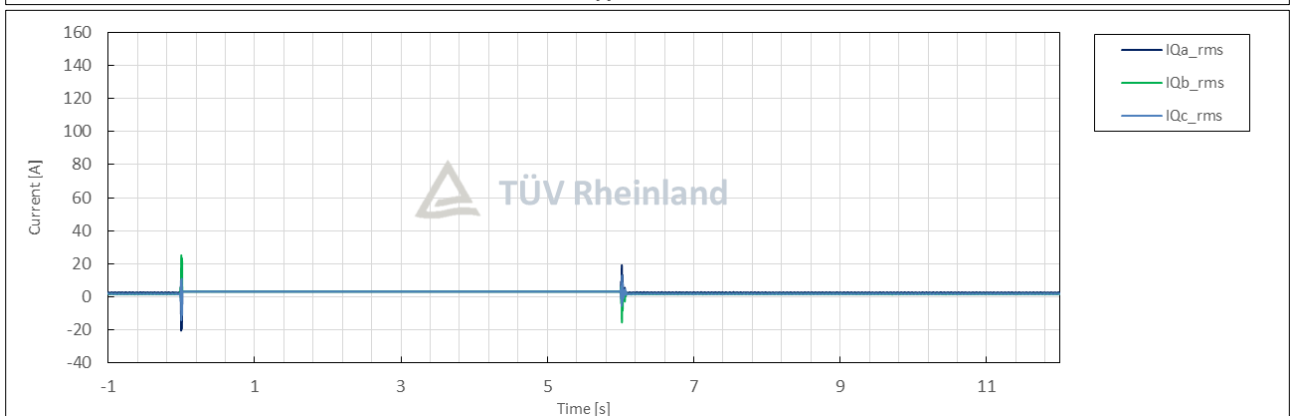
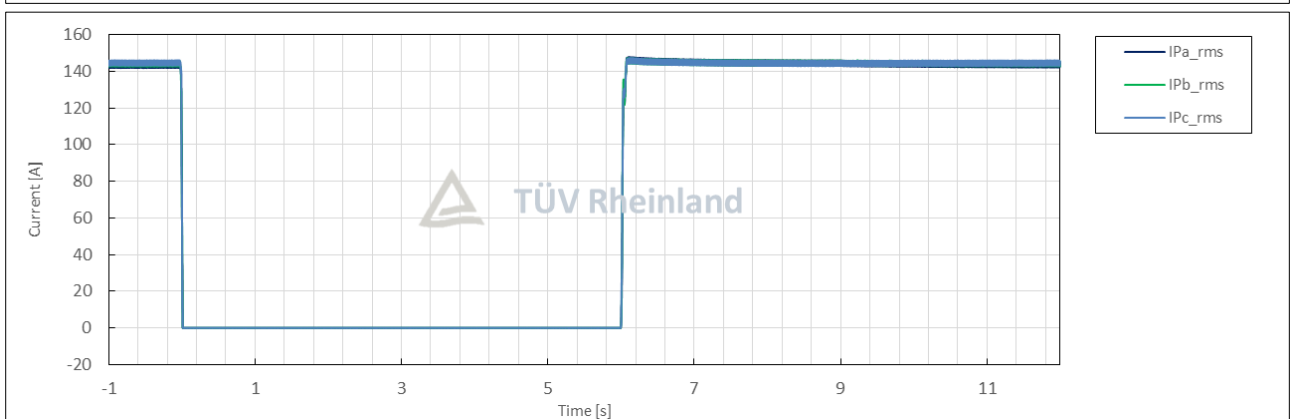
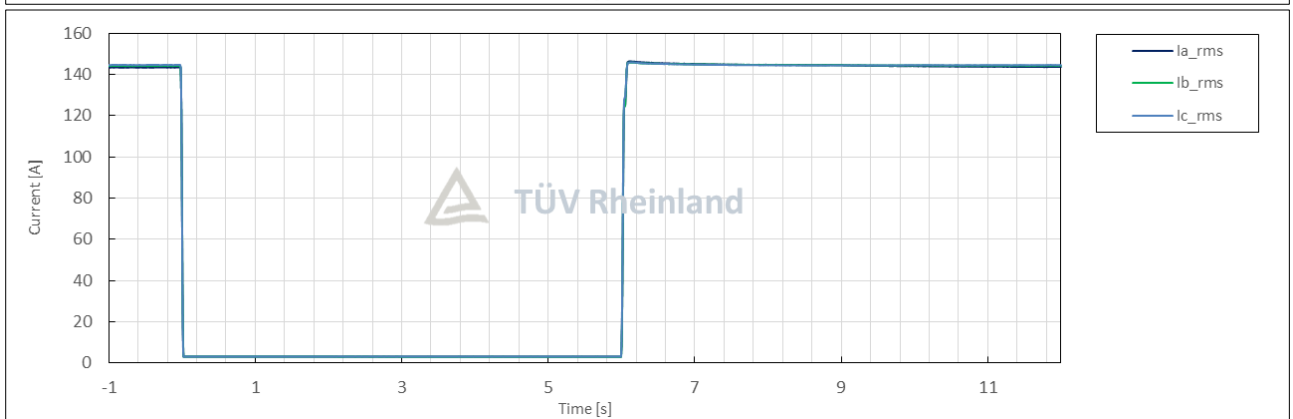
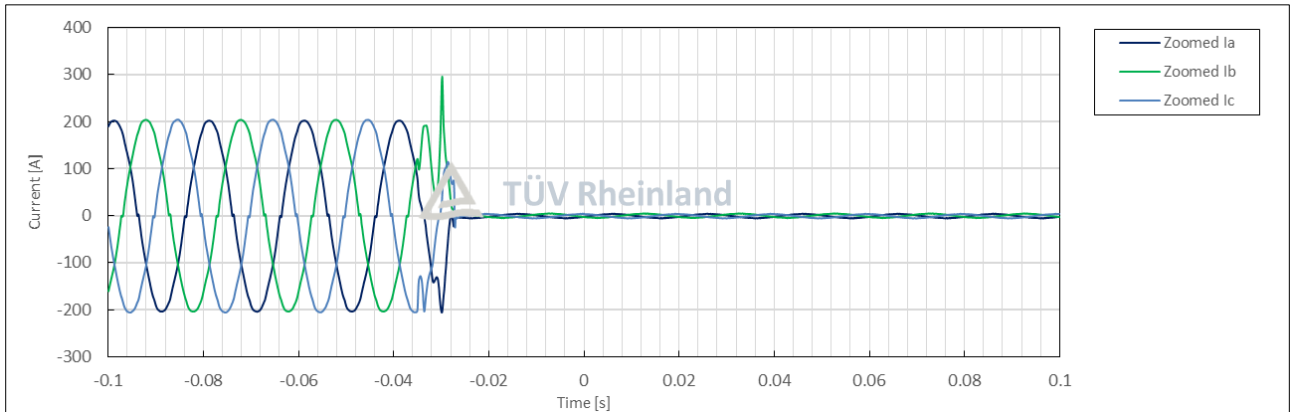

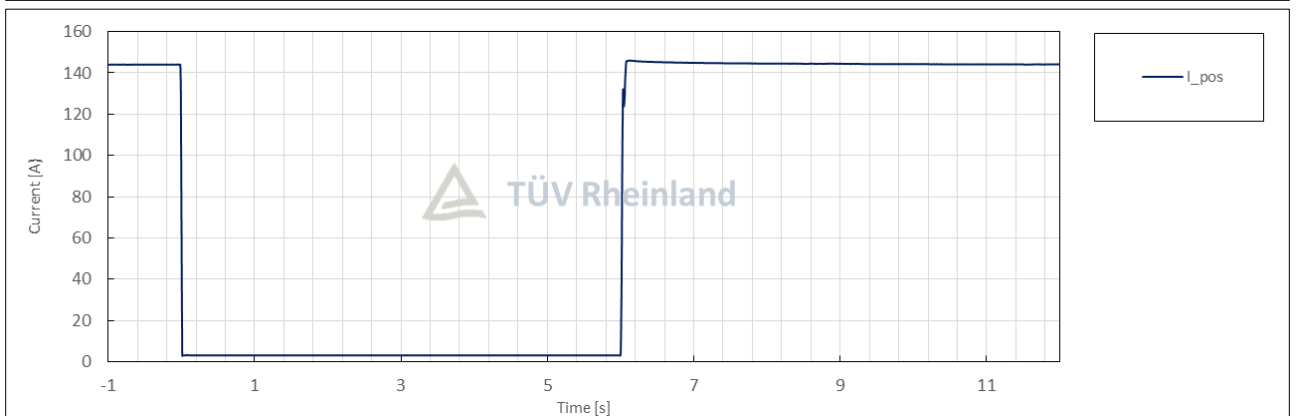
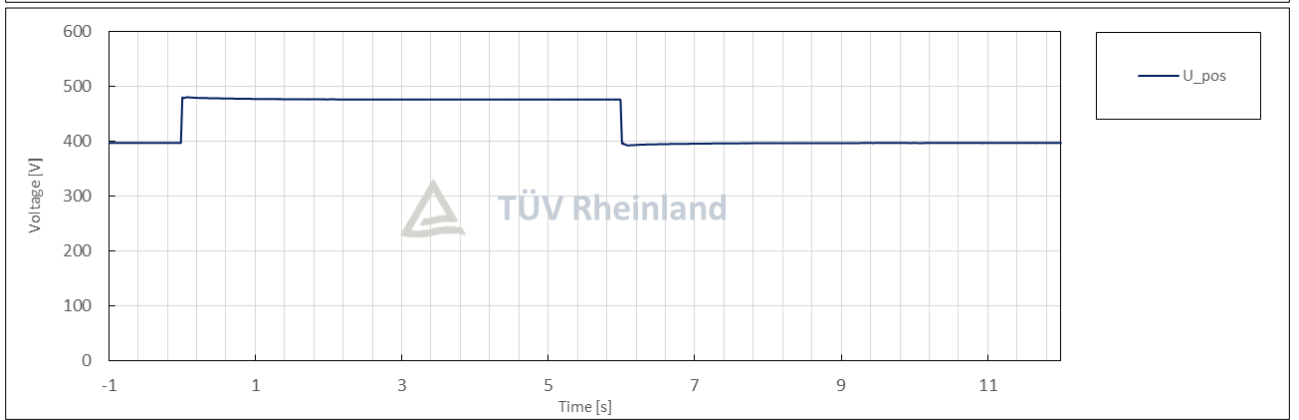
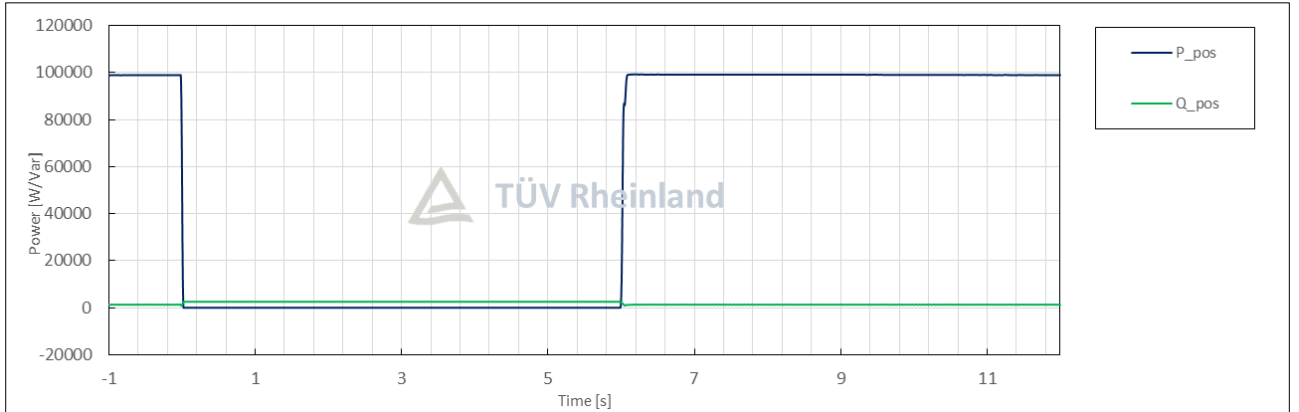

Condition						Measurement
No.	Parameter	Phase ref.	Time ref.	unit		
General Info.	0	Test number	--	--	--	6.2
	1	Date	--	--	dd.mm.yyyy	28.07.2025
	2	Time (start of test)	--	--	hh:mm:ss.f	13:54:03
	3	Fault type (phase)	--	--		3-phase fault
	4	Setting voltage depth	Line to line	--	p.u.	1.20
	5	Setting dip duration		--		5998
	6	Point of fault entry	Total	--	ms	0
	7	Point of fault clearance	Total	--	ms	5998
	8	Fault duration in empty load test	Total	--	ms	5998
	9	Voltage depth/height in empty load test	Total	t1+100ms to t2 and t1-10s to t1	p.u.	1.20
	10		Pos.		p.u.	1.20
Before dip <t1	11	Voltage	Line to neutral	t1-100s to t1	p.u.	1.00
	12	Current	Pos.	t1-500ms to t1-100ms	p.u.	0.30
	13	Active power	Total	t1-10s to t1	p.u.	0.30
	14		Pos.			0.30
	15	Reactive power	Total	t1-10s to t1	p.u.	0.00
	16		Pos.			0.00
	17	Cos ϕ	--	t1-10s to t1	--	1.000
During dip t1 to t2	18	Voltage	Line to neutral	t1+100ms to t2-20ms	p.u.	1.19
	19	Line current	Phase 1	t1+60ms	p.u.	0.02
	20		Phase 2			0.02
	21		Phase 3			0.02
	22	Line current	Phase 1	t1+100ms	p.u.	0.02
	23		Phase 2			0.02
	24		Phase 3			0.02
	25	Active power	Total	t1+100ms to t2-20ms	p.u.	0.00
	26		Pos.			0.00
After dip > t2	27	Voltage	Line to neutral	t2+3s to t2+10s	p.u.	1.00
	28	Active power	Total	t2+3s to t2+10s	p.u.	0.30
	29		Pos.			0.30
	39	Active power rising time	Pos.	--	s	0.032
	31	Reactive power	Total	t2+3s to t2+10s	p.u.	0.00
	32		Pos.			0.00
	33	Reactive power rising time	Pos.	--	s	N/A
	34	PGU does not disconnect from grid till 60s after fault	--	t2 to t2+60s	Yes / No	No

Test No. 6.2 idle test

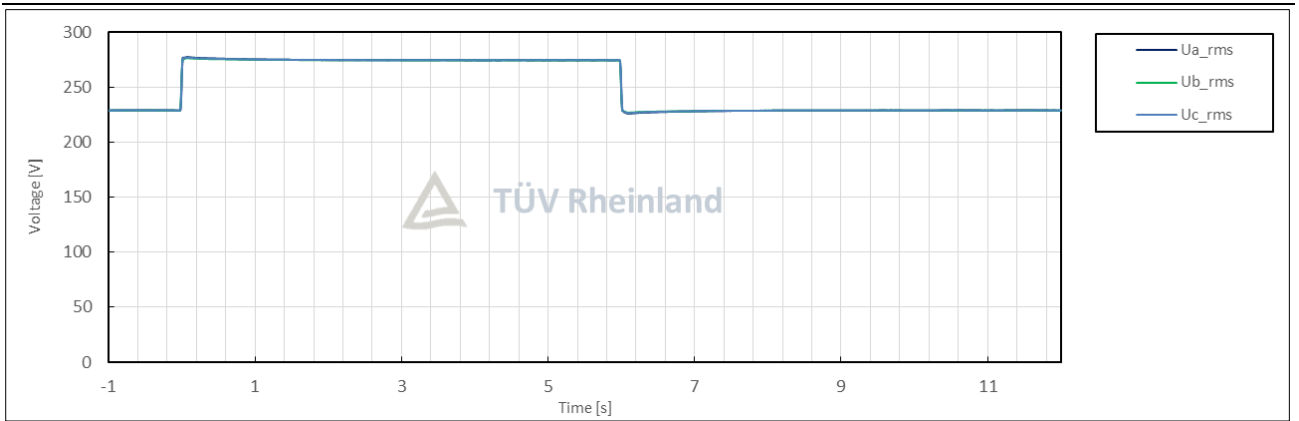
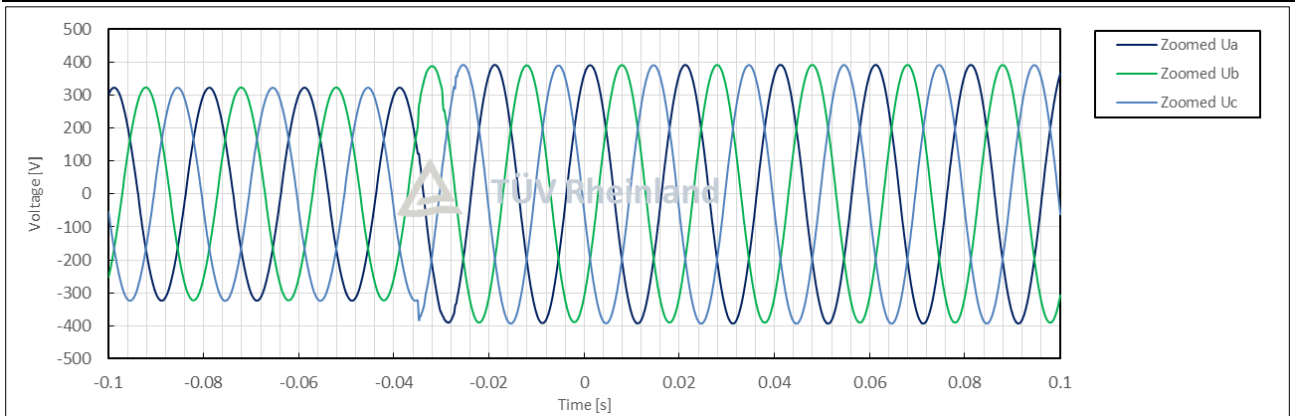
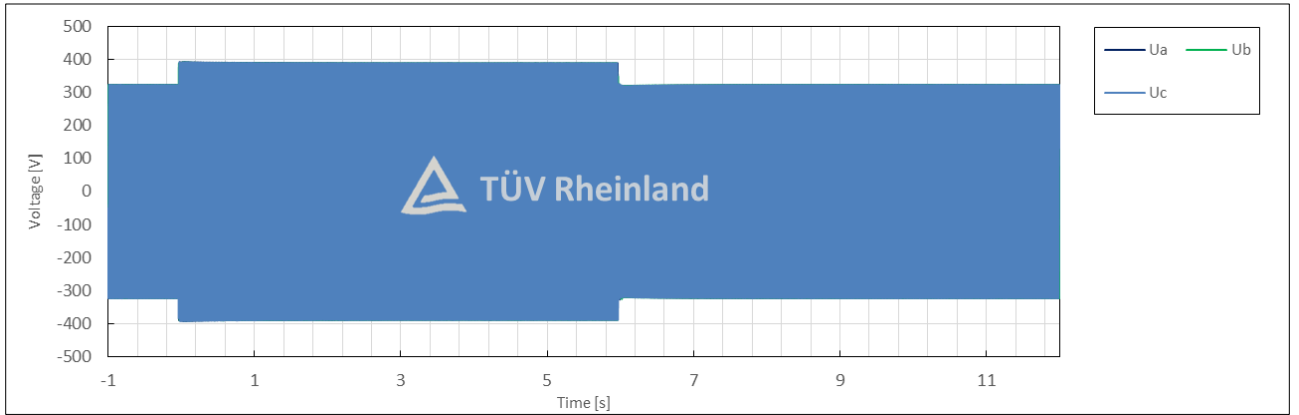

Test No. 6.2 with PGU

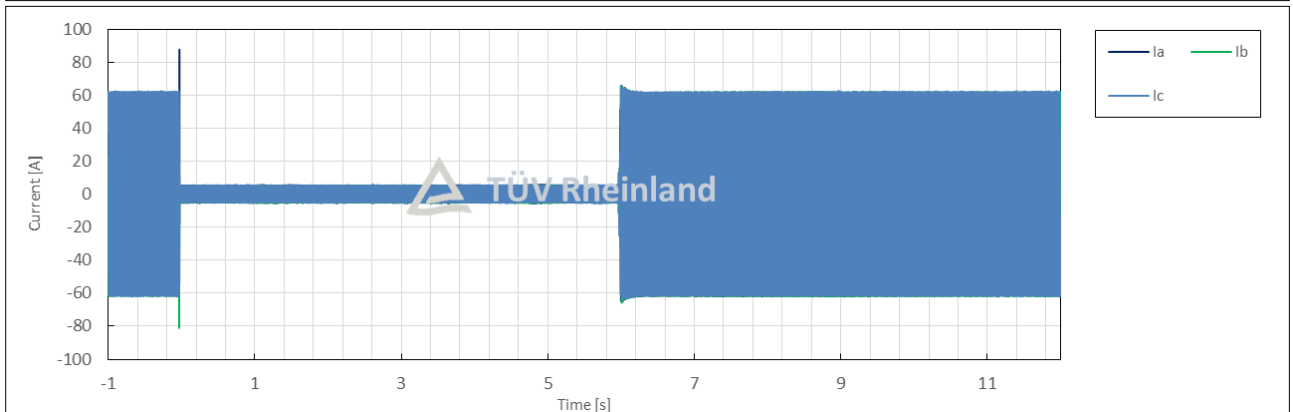
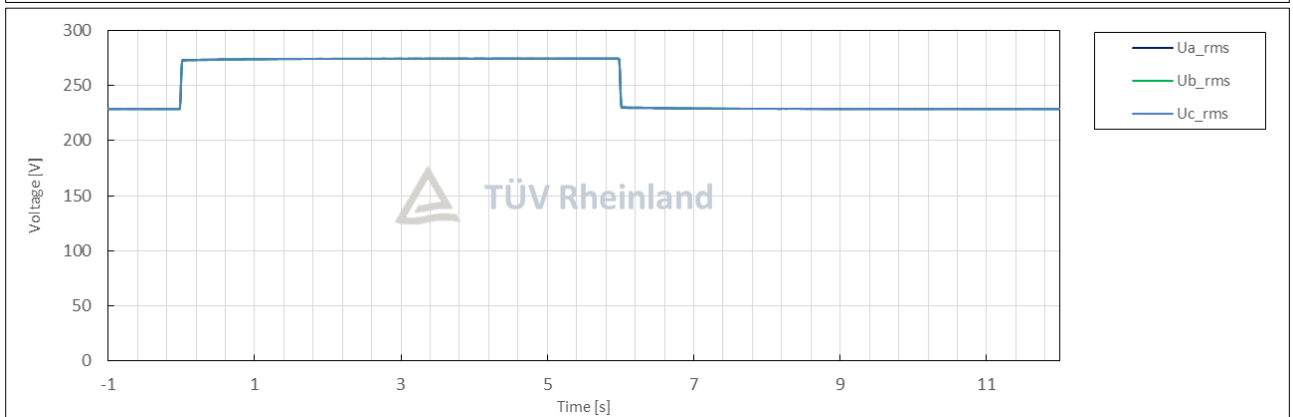
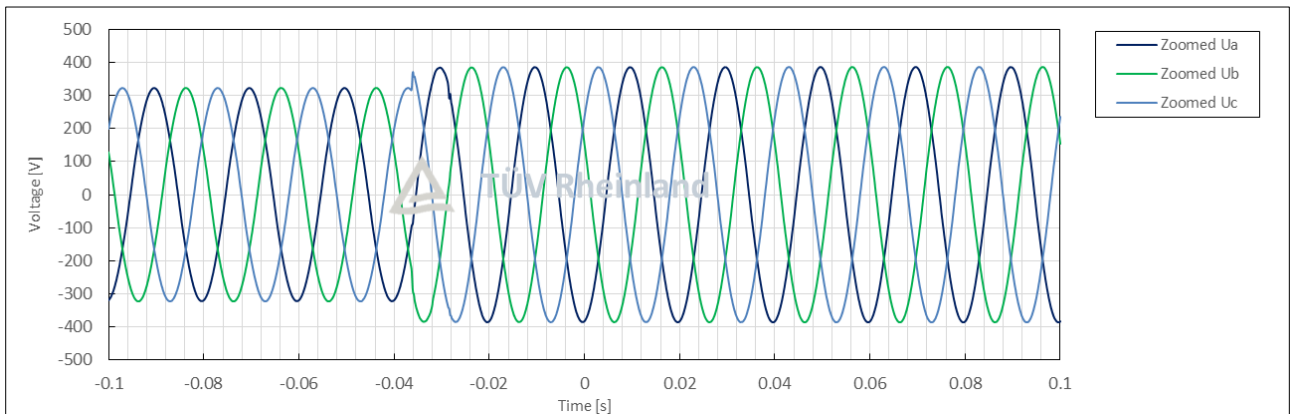
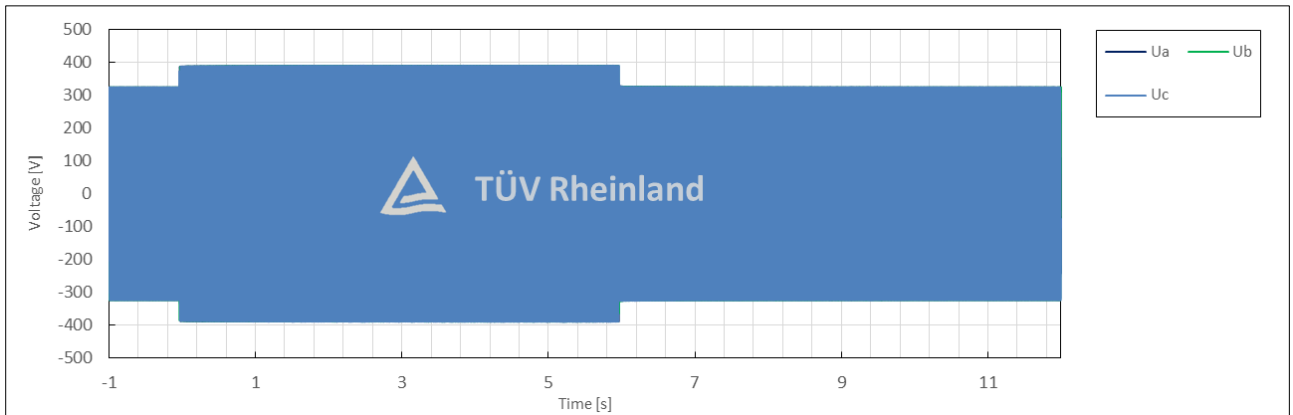

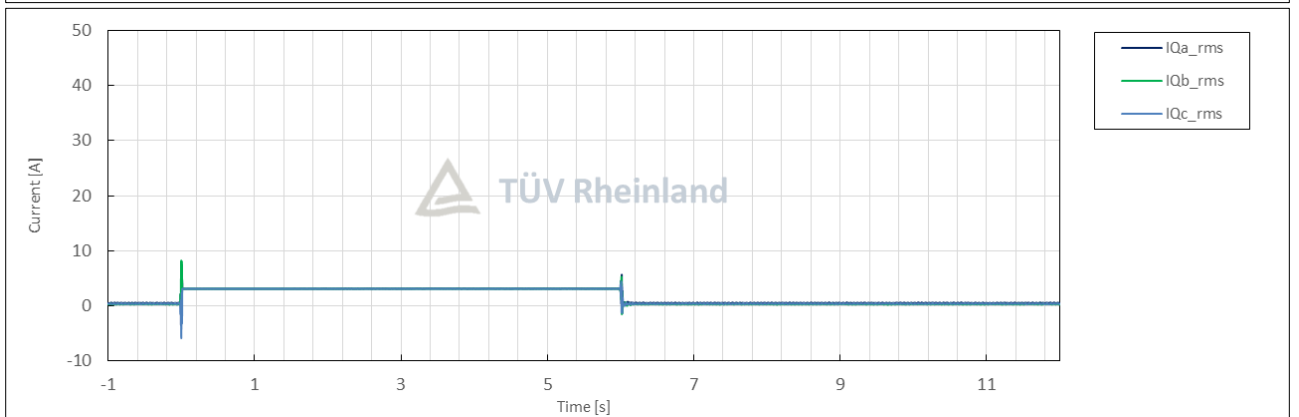
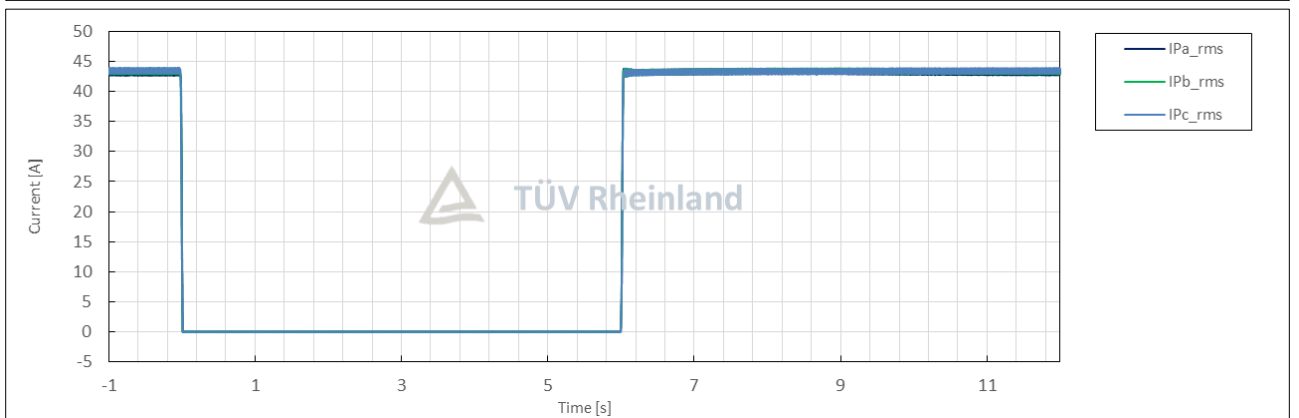
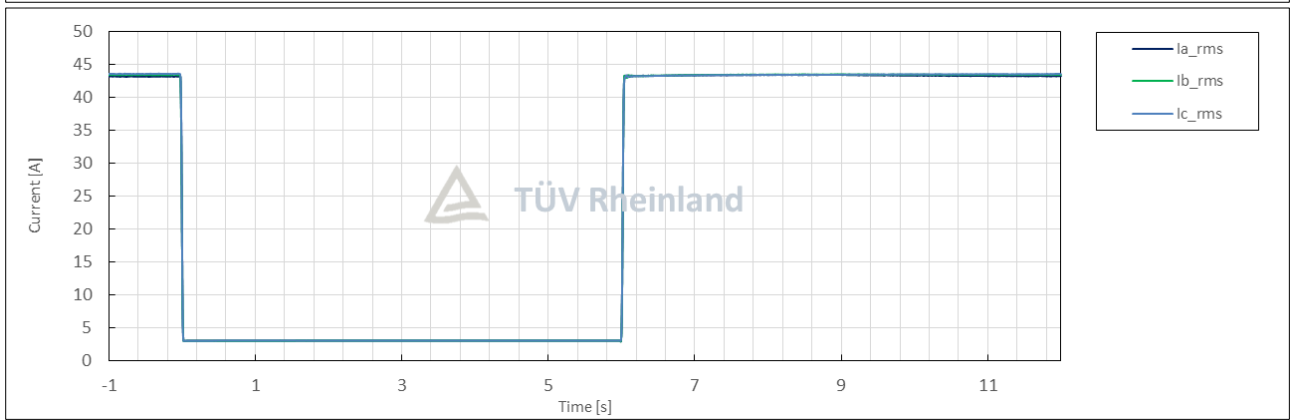
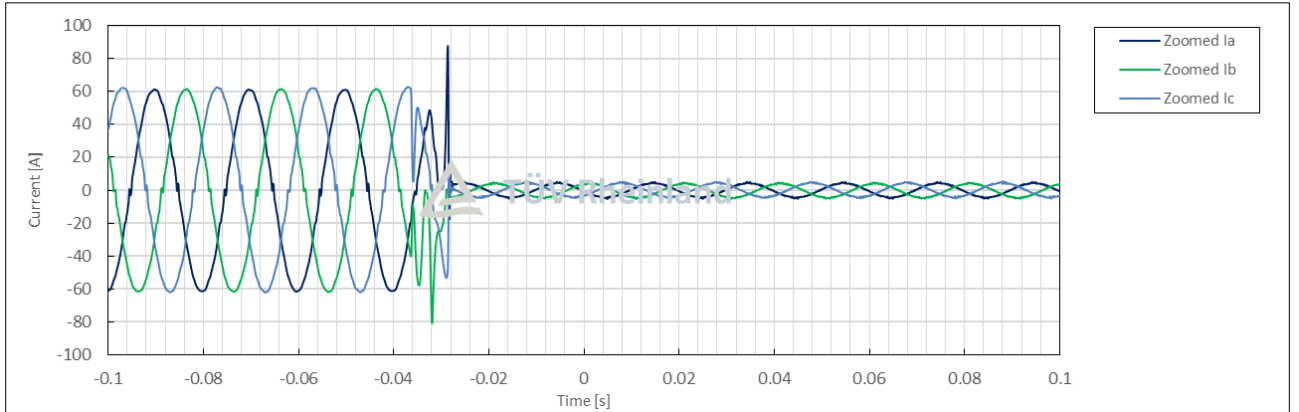

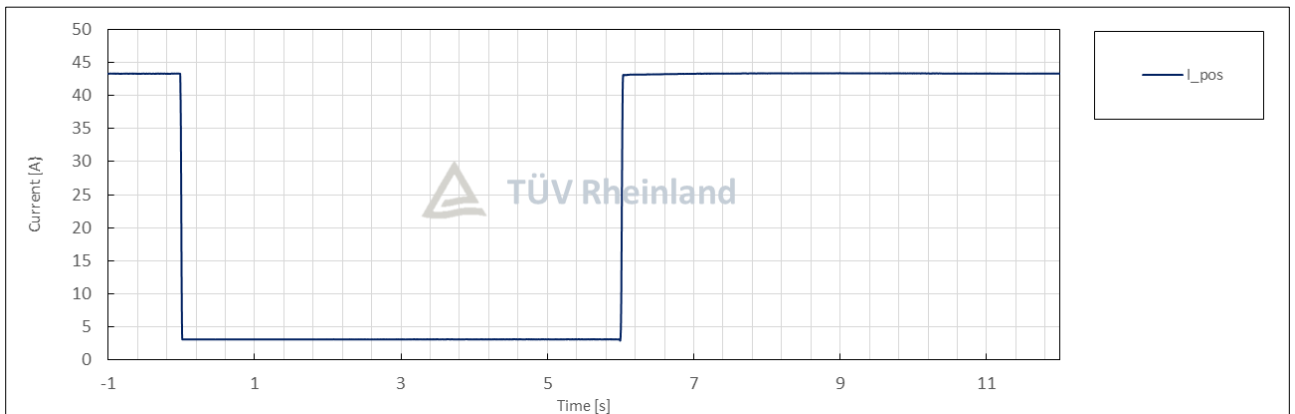
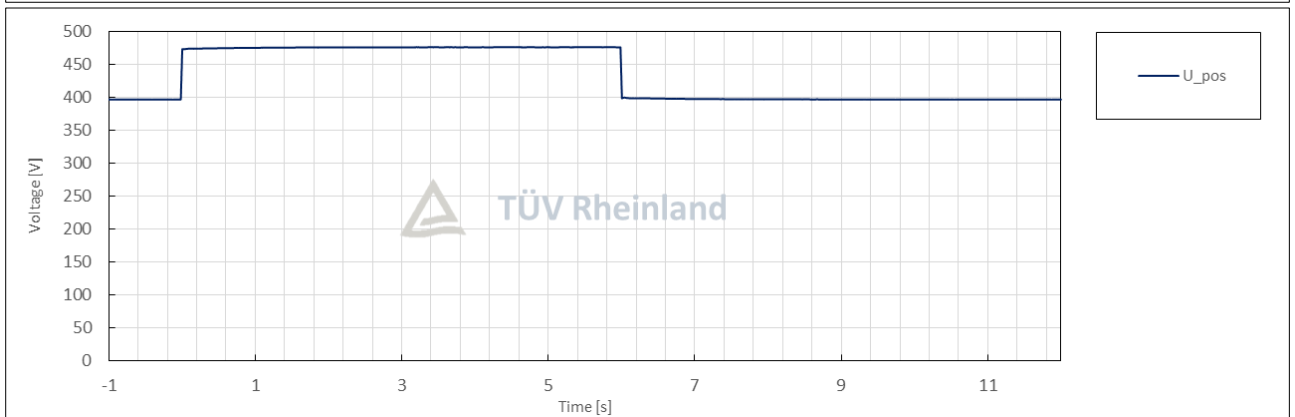
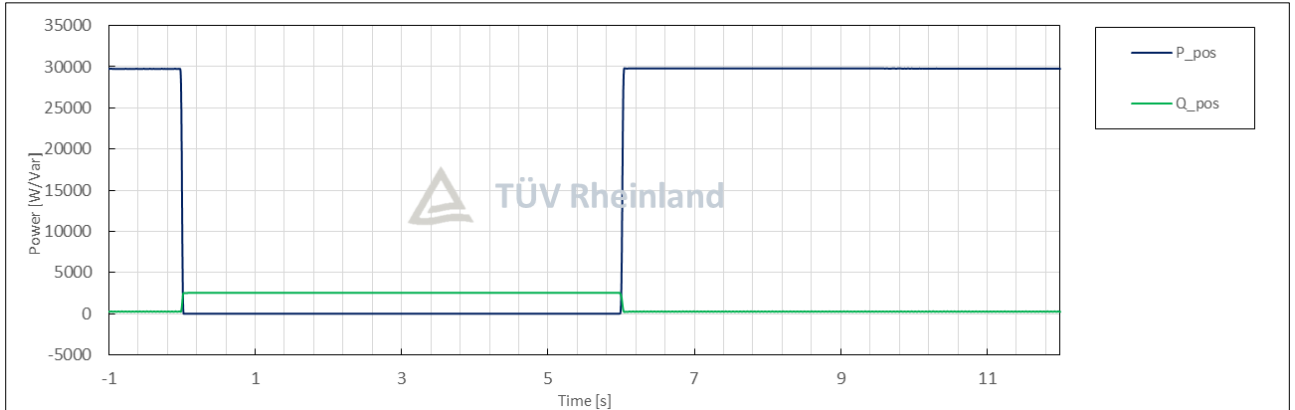

Condition						Measurement
No.	Parameter	Phase ref.	Time ref.	unit		
General Info.	0	Test number	--	--	--	6.3
	1	Date	--	--	dd.mm.yyyy	28.07.2025
	2	Time (start of test)	--	--	hh:mm:ss.f	13:54:06
	3	Fault type (phase)	--	--		2-phase fault
	4	Setting voltage depth	Line to line	--	p.u.	1.19
	5	Setting dip duration		--		5996
	6	Point of fault entry	Total	--	ms	0
	7	Point of fault clearance	Total	--	ms	5996
	8	Fault duration in empty load test	Total	--	ms	5996
	9	Voltage depth/height in empty load test	Total	t1+100ms to t2 and t1-10s to t1	p.u.	1.20
	10		Pos.		p.u.	1.10
Before dip <t1	11	Voltage	Line to neutral	t1-100s to t1	p.u.	1.00
	12	Current	Pos.	t1-500ms to t1-100ms	p.u.	0.99
	13	Active power	Total	t1-10s to t1	p.u.	0.99
	14		Pos.			0.99
	15	Reactive power	Total	t1-10s to t1	p.u.	0.01
	16		Pos.			0.01
	17	Cos ϕ	--	t1-10s to t1	--	1.000
During dip t1 to t2	18	Voltage	Line to neutral	t1+100ms to t2-20ms	p.u.	1.19
	19	Line current	Phase 1	t1+60ms	p.u.	0.02
	20		Phase 2			0.02
	21		Phase 3			0.02
	22	Line current	Phase 1	t1+100ms	p.u.	0.02
	23		Phase 2			0.02
	24		Phase 3			0.02
	25	Active power	Total	t1+100ms to t2-20ms	p.u.	0.00
	26		Pos.			0.00
After dip > t2	27	Voltage	Line to neutral	t2+3s to t2+10s	p.u.	1.00
	28	Active power	Total	t2+3s to t2+10s	p.u.	0.99
	29		Pos.			0.99
	39	Active power rising time	Pos.	--	s	0.038
	31	Reactive power	Total	t2+3s to t2+10s	p.u.	0.01
	32		Pos.			0.01
	33	Reactive power rising time	Pos.	--	s	N/A
	34	PGU does not disconnect from grid till 60s after fault	--	t2 to t2+60s	Yes / No	No

Test No. 6.3 idle test

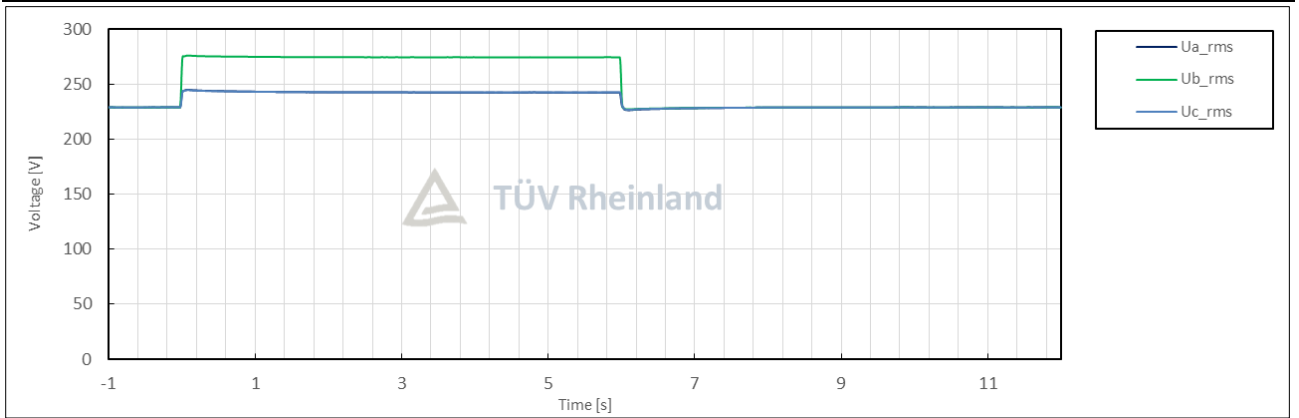
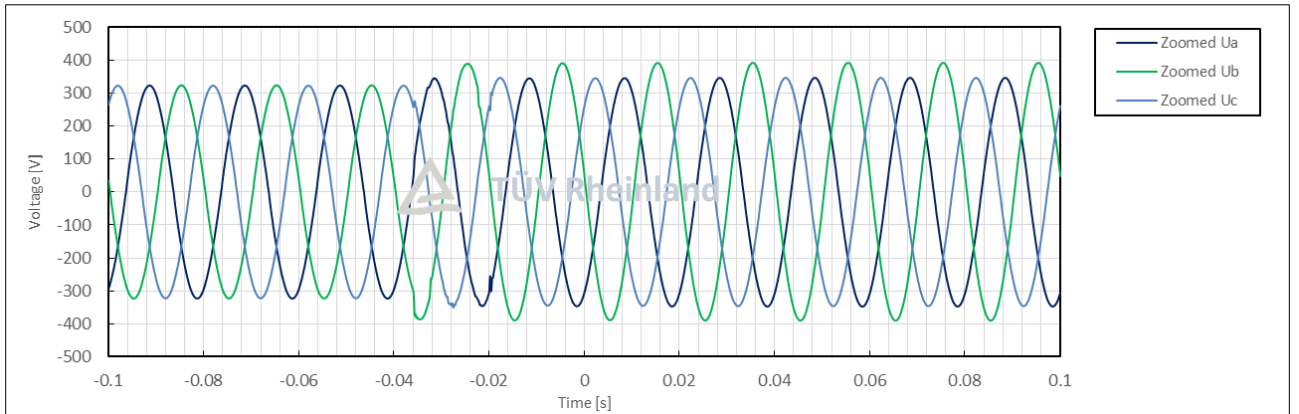
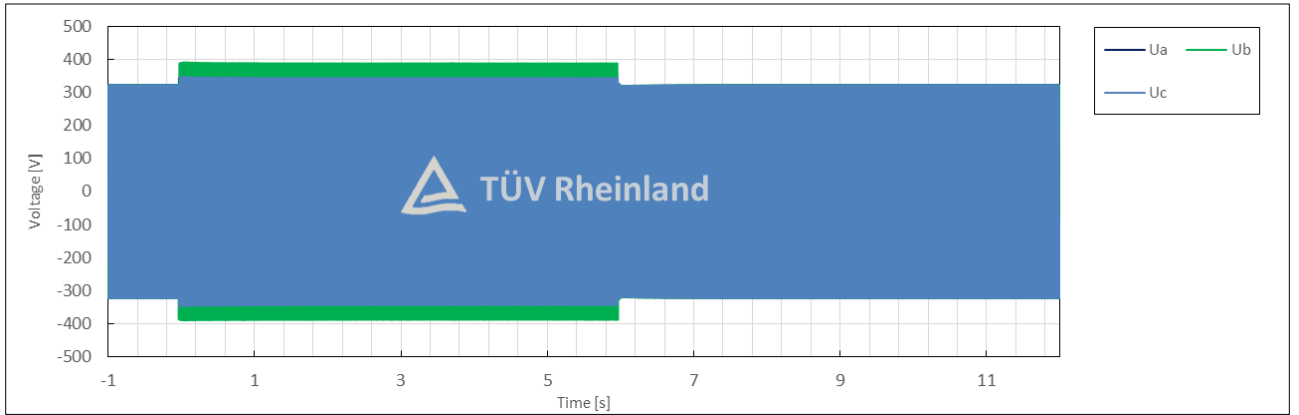

Test No. 6.3 with PGU

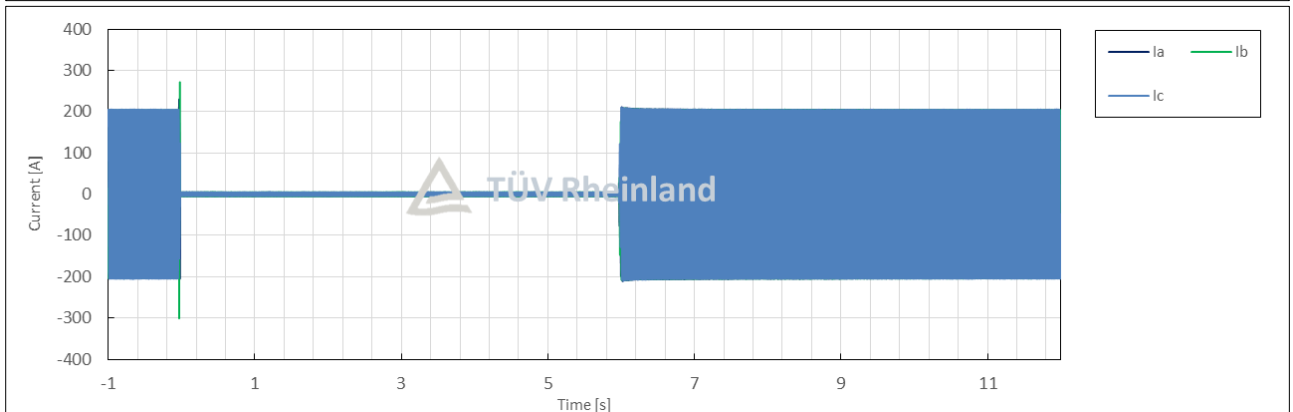
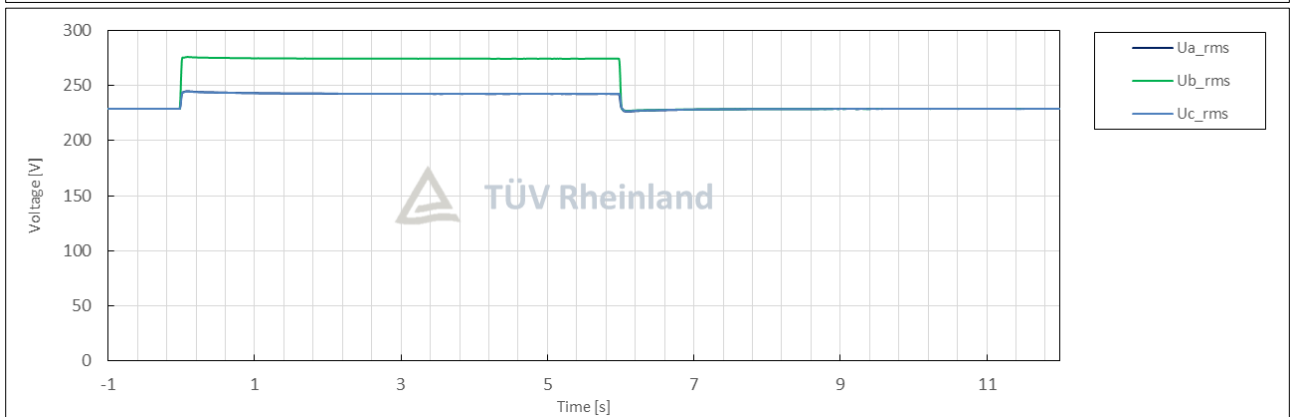
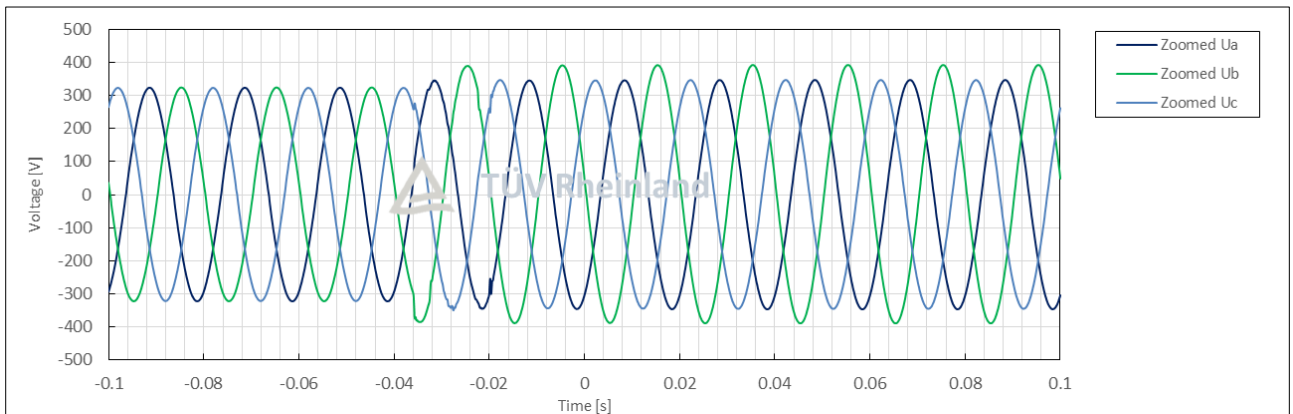
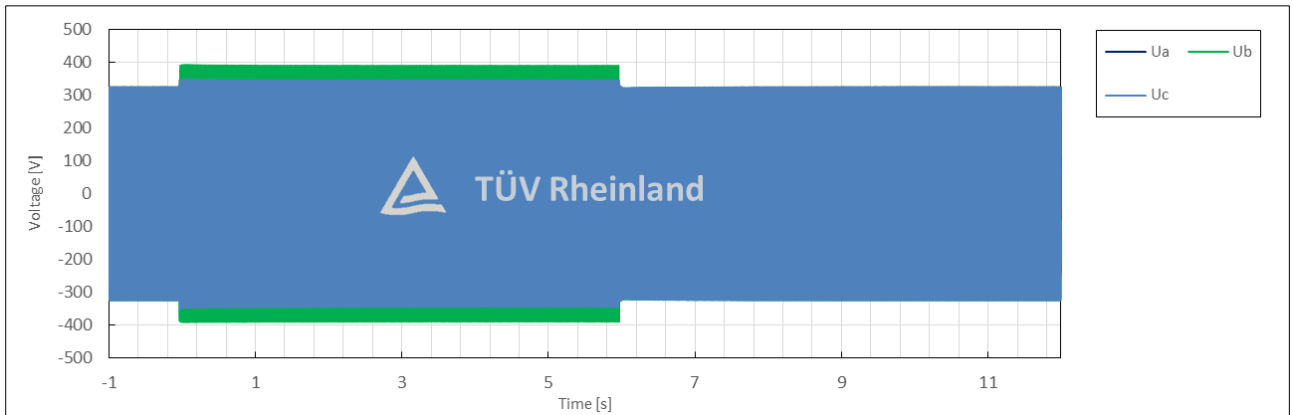

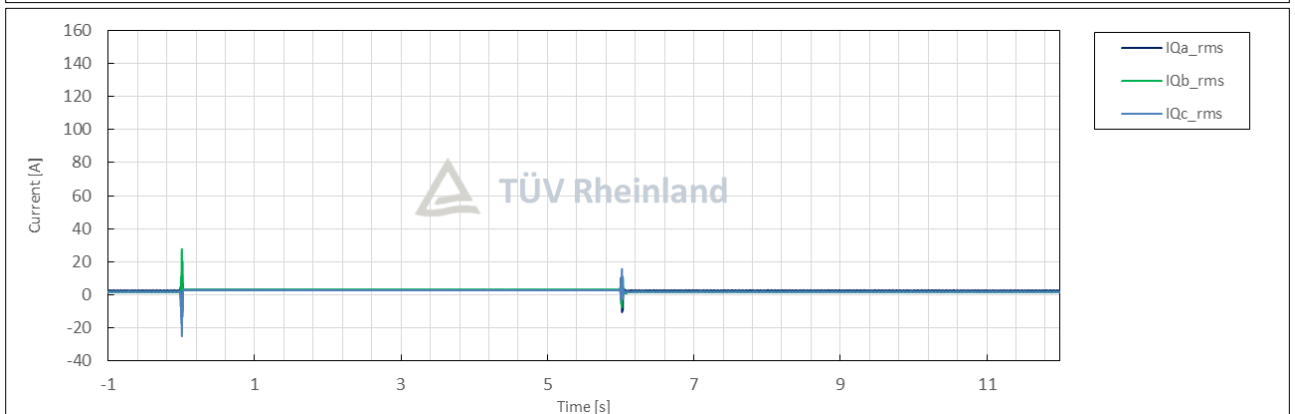
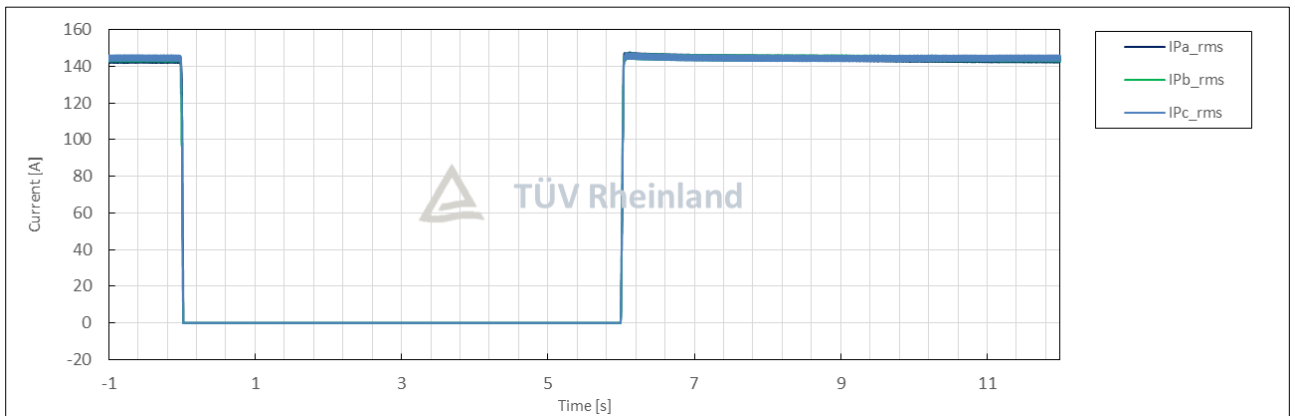
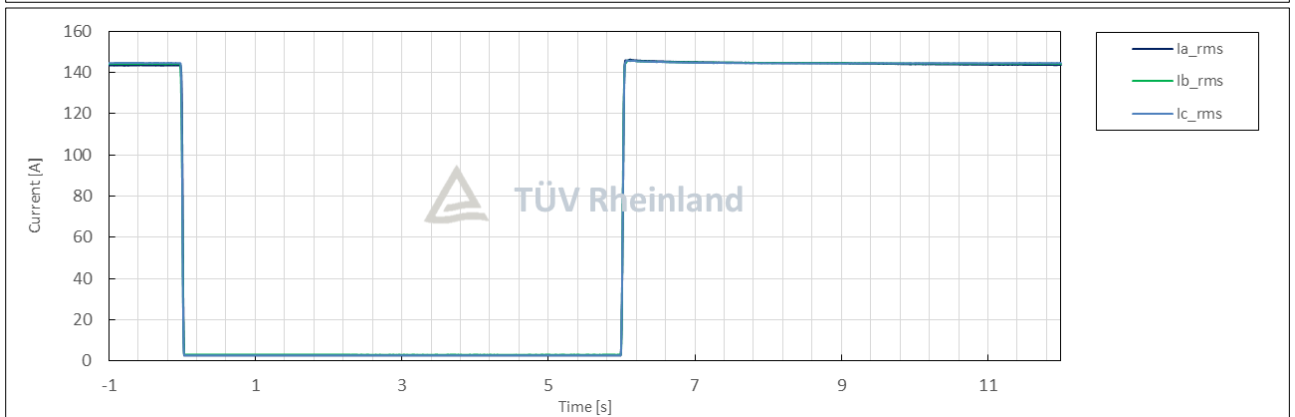
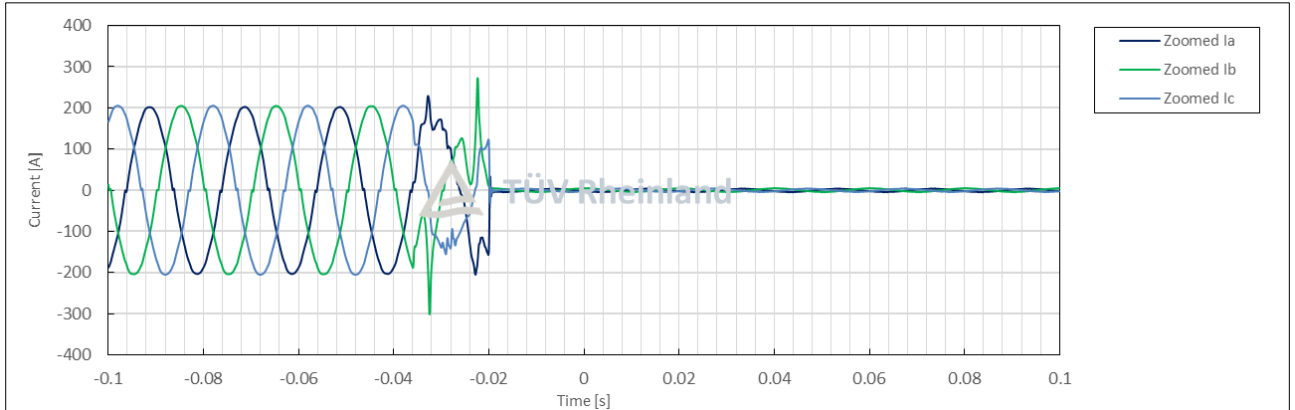

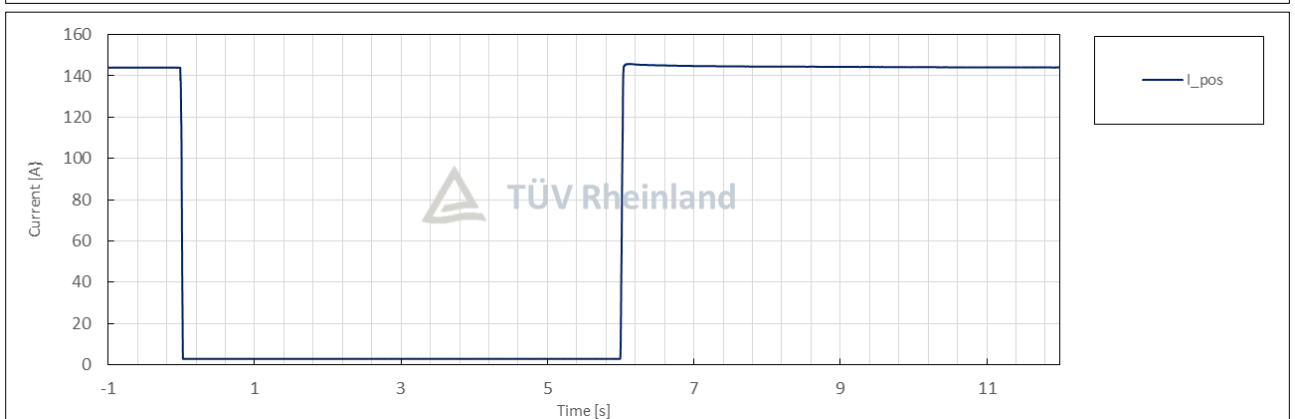
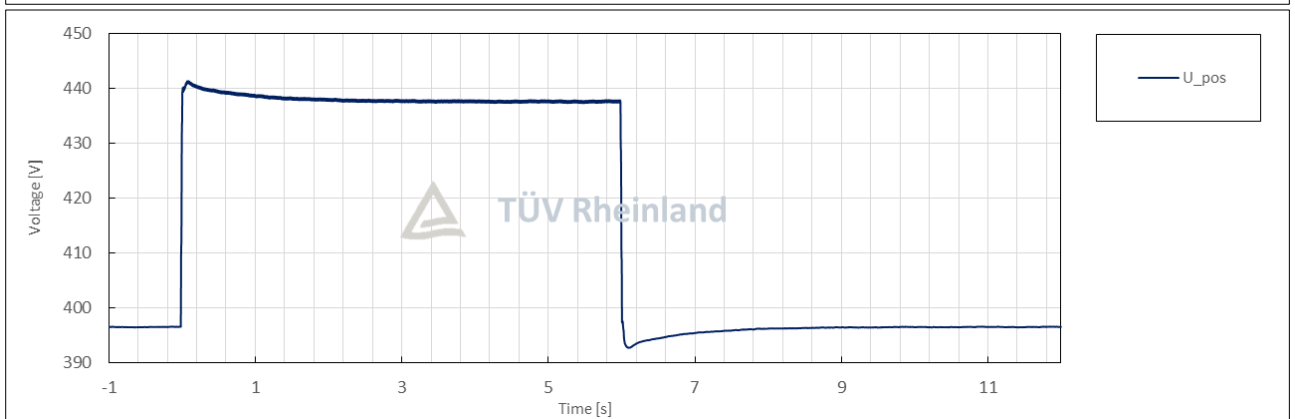
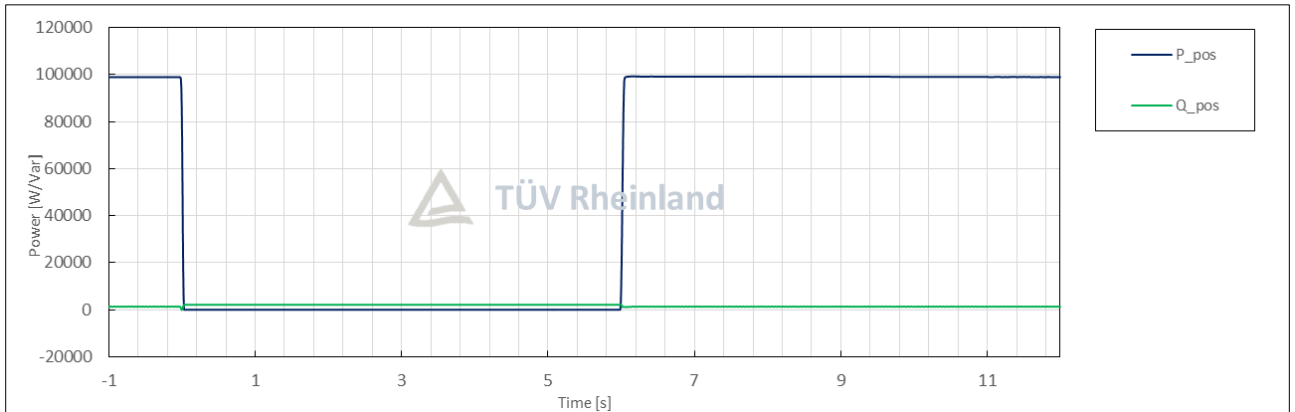

Condition						Measurement
No.	Parameter	Phase ref.	Time ref.	unit		
General Info.	0	Test number	--	--	--	6.4
	1	Date	--	--	dd.mm.yyyy	28.07.2025
	2	Time (start of test)	--	--	hh:mm:ss.f	13:54:29
	3	Fault type (phase)	--	--		2-phase fault
	4	Setting voltage depth	Line to line	--	p.u.	1.19
	5	Setting dip duration		--		5996
	6	Point of fault entry	Total	--	ms	0
	7	Point of fault clearance	Total	--	ms	5996
	8	Fault duration in empty load test	Total	--	ms	5996
	9	Voltage depth/height in empty load test	Total	t1+100ms to t2 and t1-10s to t1	p.u.	1.20
	10		Pos.		p.u.	1.10
Before dip <t1	11	Voltage	Line to neutral	t1-100s to t1	p.u.	1.00
	12	Current	Pos.	t1-500ms to t1-100ms	p.u.	0.30
	13	Active power	Total	t1-10s to t1	p.u.	0.30
	14		Pos.			0.30
	15	Reactive power	Total	t1-10s to t1	p.u.	0.00
	16		Pos.			0.00
	17	Cos ϕ	--	t1-10s to t1	--	1.000
During dip t1 to t2	18	Voltage	Line to neutral	t1+100ms to t2-20ms	p.u.	1.19
	19	Line current	Phase 1	t1+60ms	p.u.	0.02
	20		Phase 2			0.02
	21		Phase 3			0.02
	22	Line current	Phase 1	t1+100ms	p.u.	0.02
	23		Phase 2			0.02
	24		Phase 3			0.02
	25	Active power	Total	t1+100ms to t2-20ms	p.u.	0.00
	26		Pos.			0.00
After dip > t2	27	Voltage	Line to neutral	t2+3s to t2+10s	p.u.	1.00
	28	Active power	Total	t2+3s to t2+10s	p.u.	0.30
	29		Pos.			0.30
	39	Active power rising time	Pos.	--	s	0.028
	31	Reactive power	Total	t2+3s to t2+10s	p.u.	0.00
	32		Pos.			0.00
	33	Reactive power rising time	Pos.	--	s	N/A
	34	PGU does not disconnect from grid till 60s after fault	--	t2 to t2+60s	Yes / No	No

Test No. 6.4 idle test

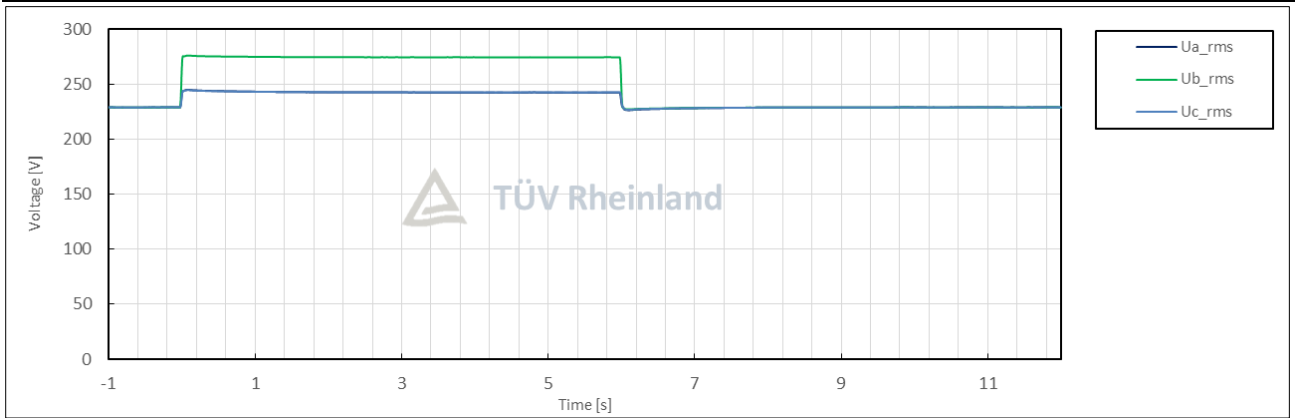
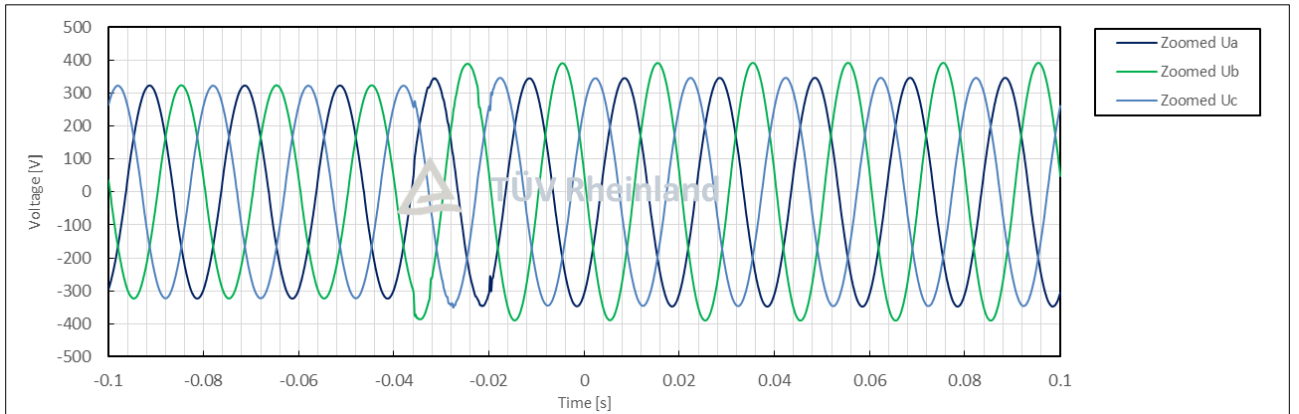
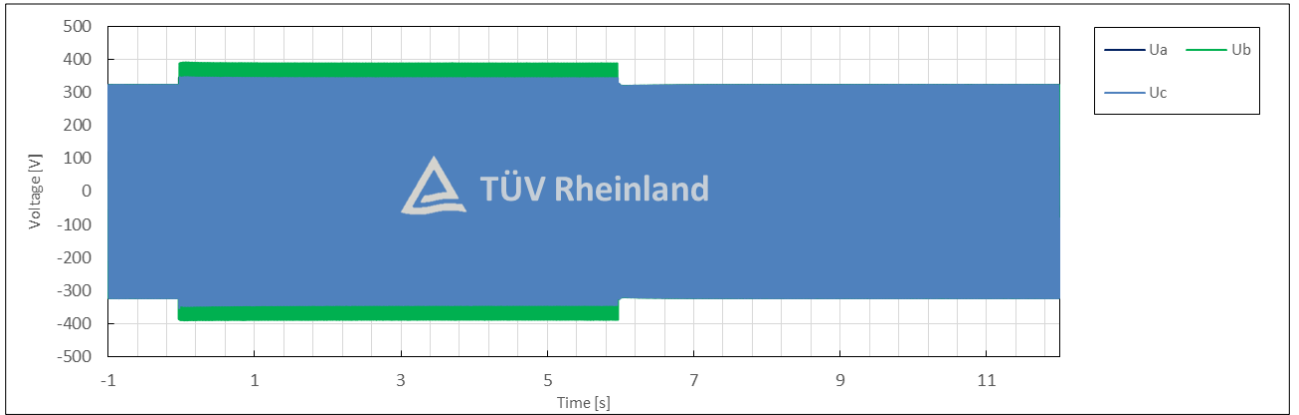

Test No. 6.4 with PGU

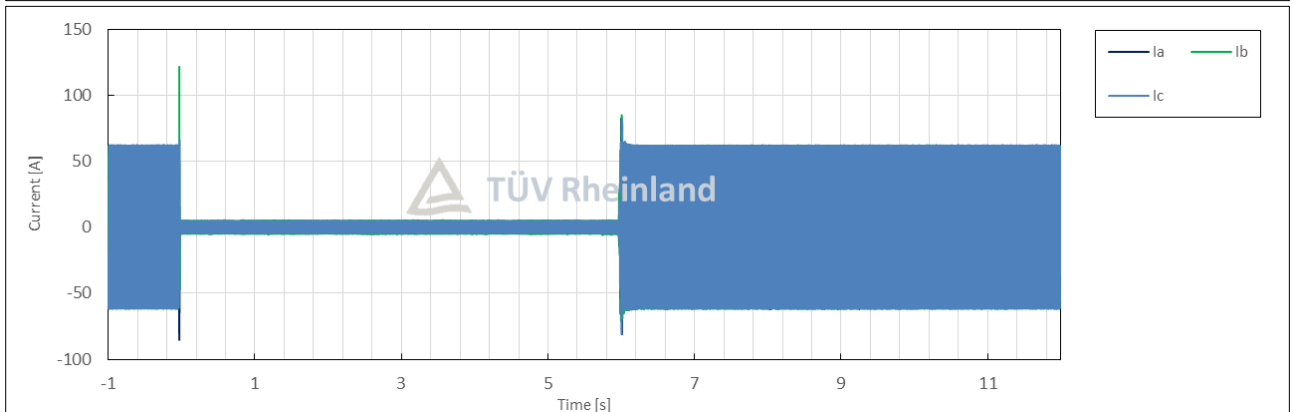
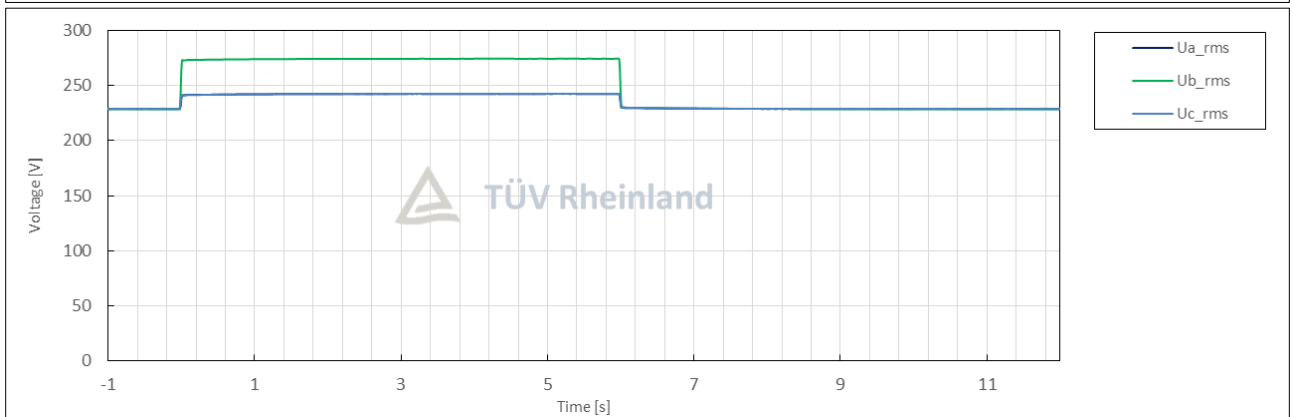
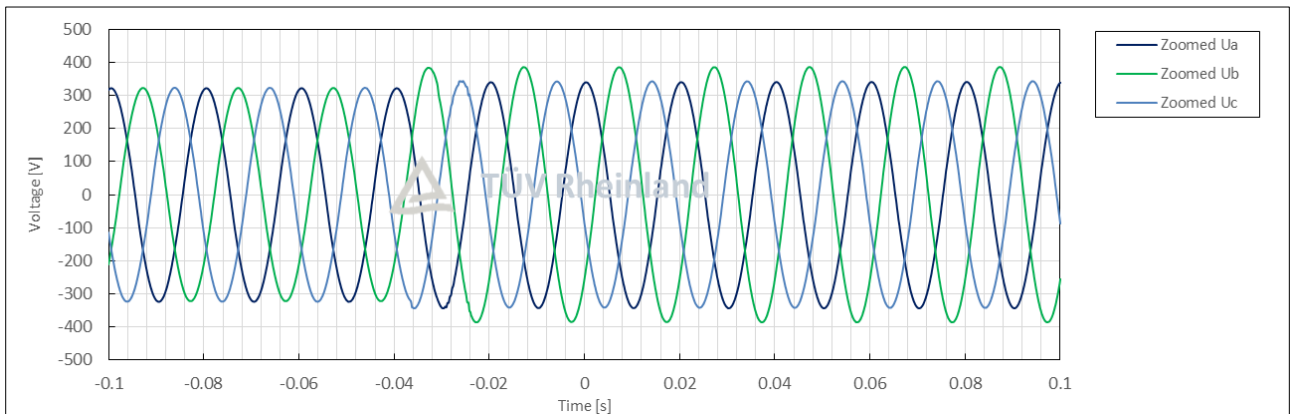
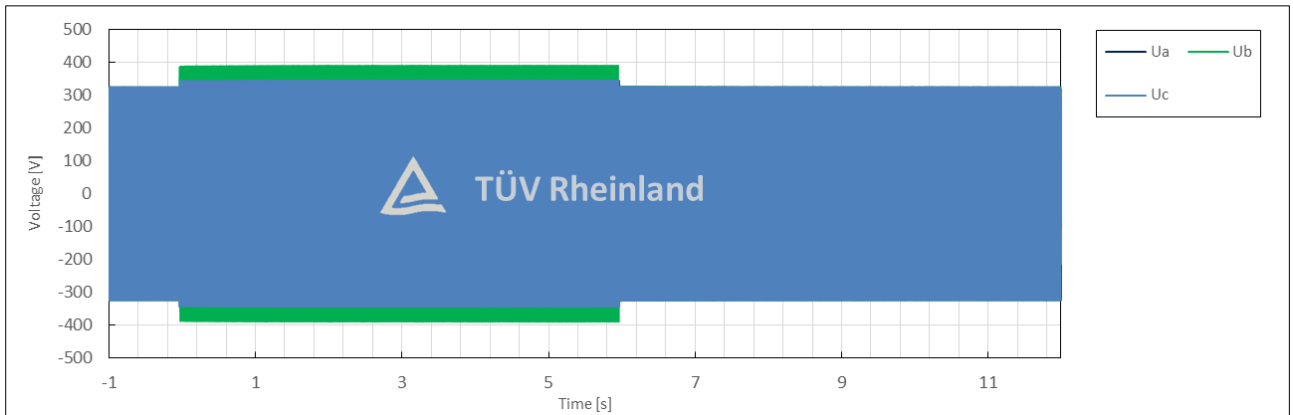

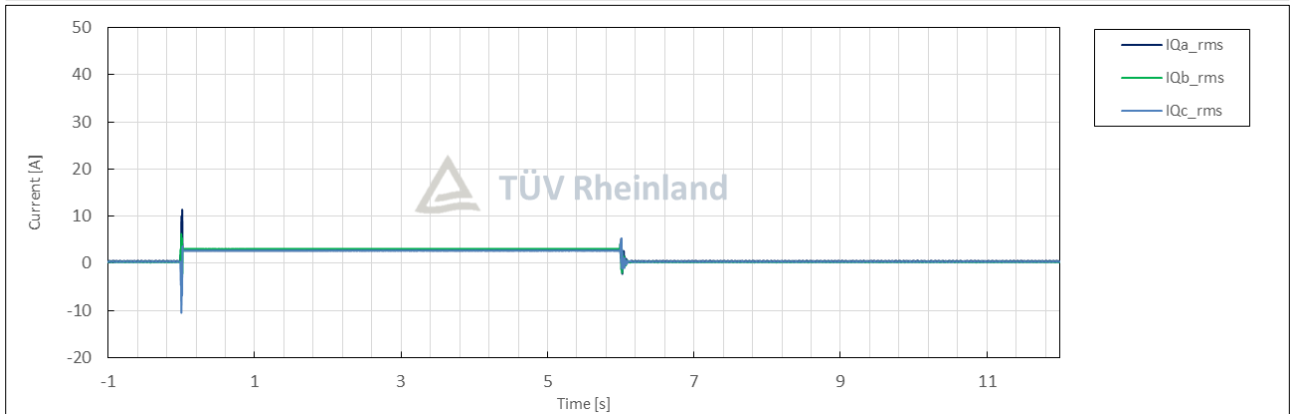
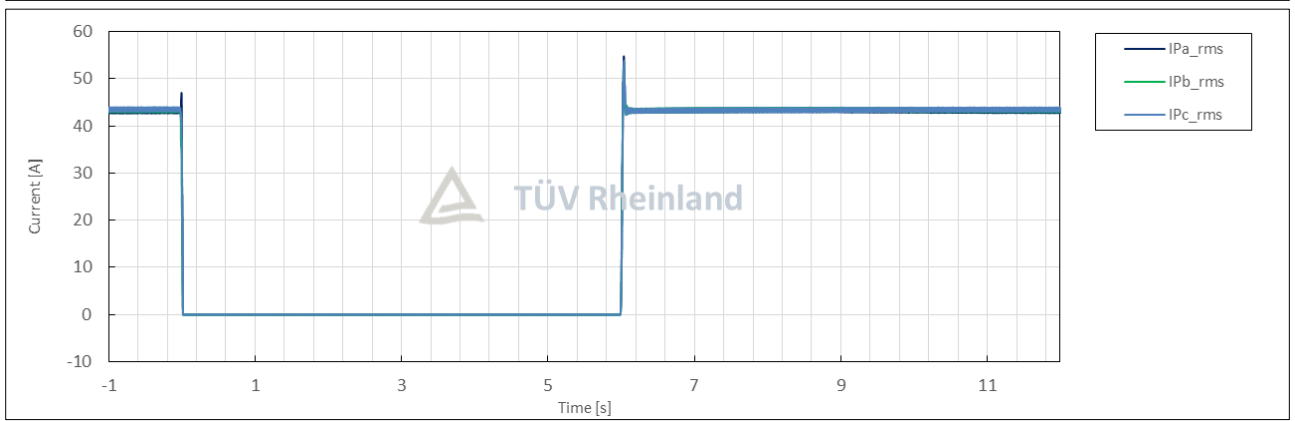
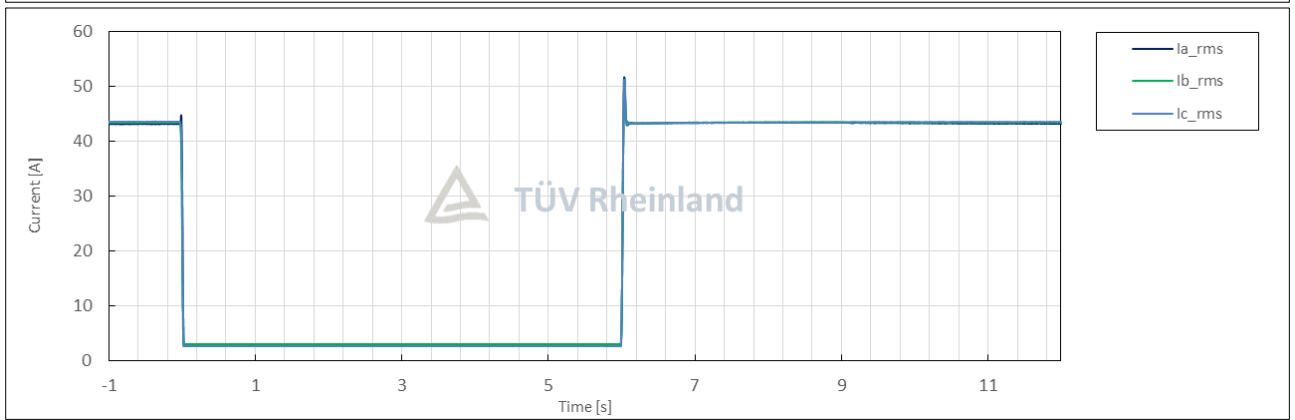
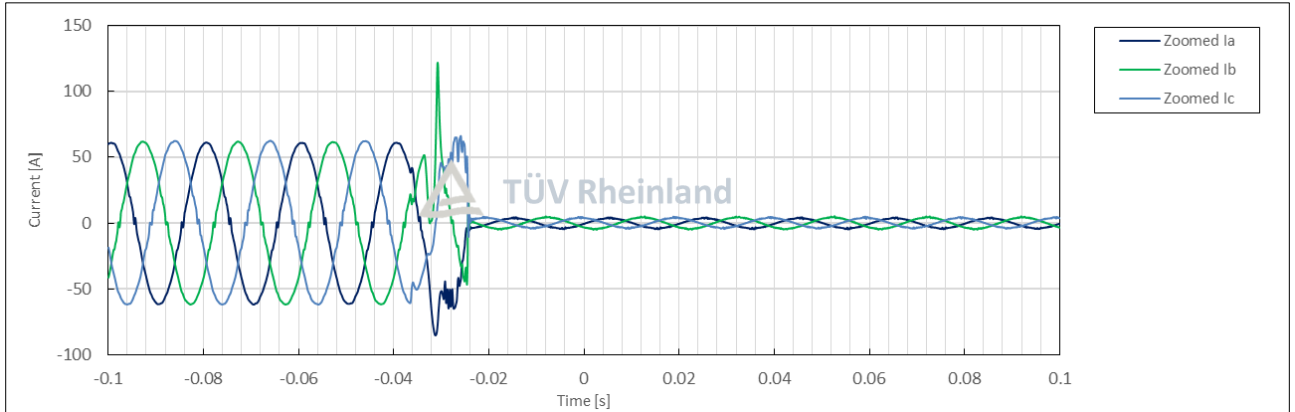

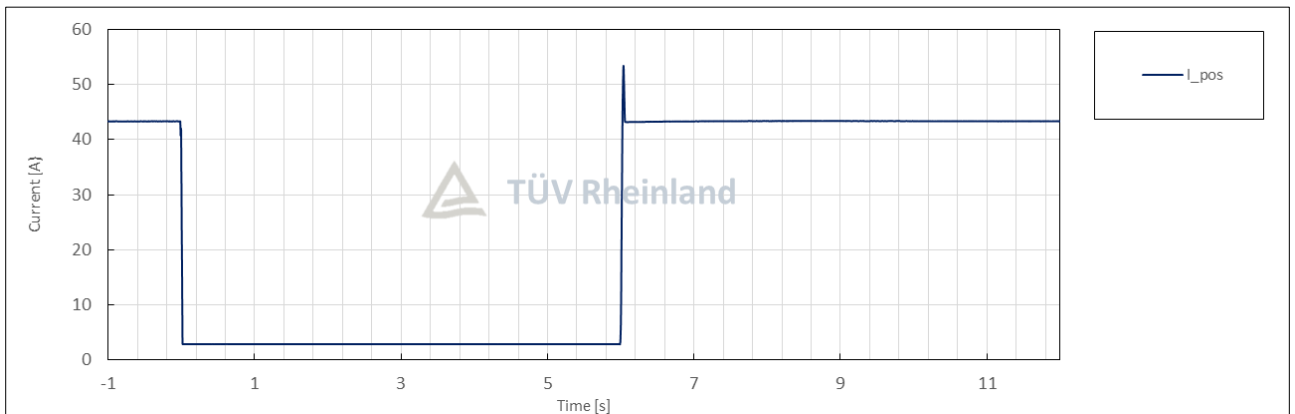
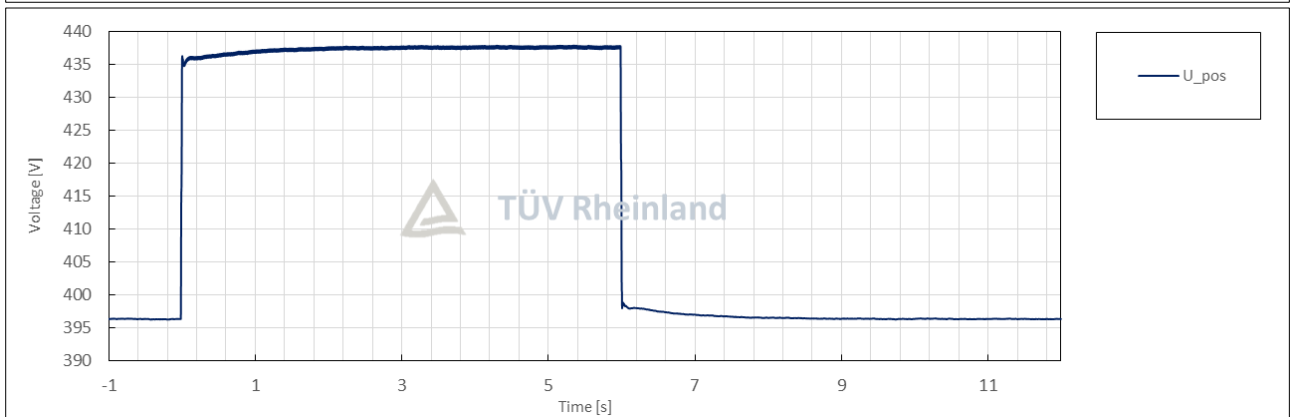
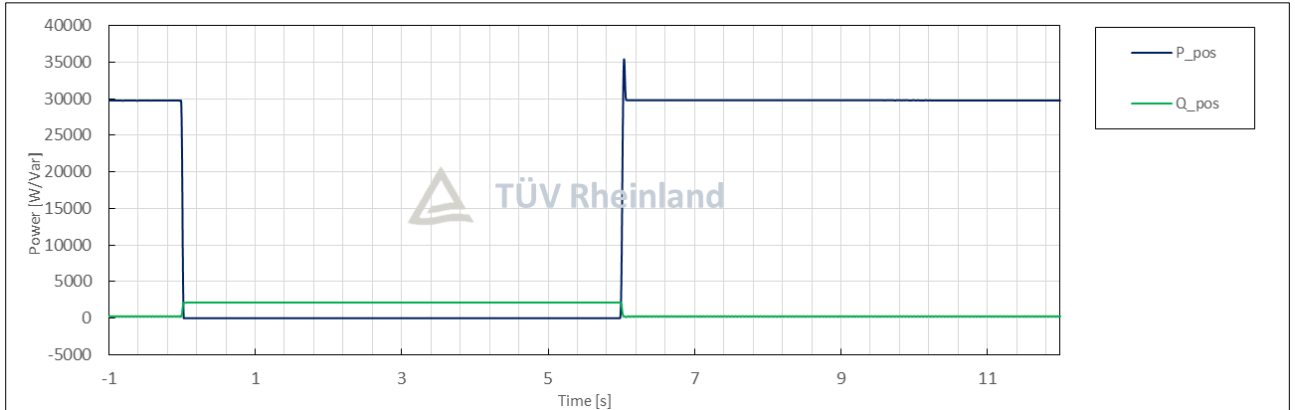

Condition						Measurement
No.	Parameter	Phase ref.	Time ref.	unit		
General Info.	0	Test number	--	--	--	7.1
	1	Date	--	--	dd.mm.yyyy	28.07.2025
	2	Time (start of test)	--	--	hh:mm:ss.f	13:55:23
	3	Fault type (phase)	--	--		3-phase fault
	4	Setting voltage depth	Line to line	--	p.u.	1.14
	5	Setting dip duration		--		61006
	6	Point of fault entry	Total	--	ms	0
	7	Point of fault clearance	Total	--	ms	61006
	8	Fault duration in empty load test	Total	--	ms	61006
	9	Voltage depth/height in empty load test	Total	t1+100ms to t2 and t1-10s to t1	p.u.	1.15
10	Pos.		p.u.		1.15	
Before dip <t1	11	Voltage	Line to neutral	t1-100s to t1	p.u.	1.00
	12	Current	Pos.	t1-500ms to t1-100ms	p.u.	0.99
	13	Active power	Total	t1-10s to t1	p.u.	0.99
	14		Pos.			0.99
	15	Reactive power	Total	t1-10s to t1	p.u.	0.01
	16		Pos.			0.01
17	Cos ϕ	--	t1-10s to t1	--	1.000	
During dip t1 to t2	18	Voltage	Line to neutral	t1+100ms to t2-20ms	p.u.	1.14
	19	Line current	Phase 1	t1+60ms	p.u.	0.74
	20		Phase 2			0.76
	21		Phase 3			0.77
	22	Line current	Phase 1	t1+100ms	p.u.	0.83
	23		Phase 2			0.83
	24		Phase 3			0.83
	25	Active power	Total	t1+100ms to t2-20ms	p.u.	0.99
26	Pos.		0.99			
After dip > t2	27	Voltage	Line to neutral	t2+3s to t2+10s	p.u.	1.00
	28	Active power	Total	t2+3s to t2+10s	p.u.	0.99
	29		Pos.			0.99
	39	Active power rising time	Pos.	--	s	N/A
	31	Reactive power	Total	t2+3s to t2+10s	p.u.	0.01
	32		Pos.			0.01
	33	Reactive power rising time	Pos.	--	s	N/A
34	PGU does not disconnect from grid till 60s after fault	--	t2 to t2+60s	Yes / No	No	

Test No. 7.1 idle test

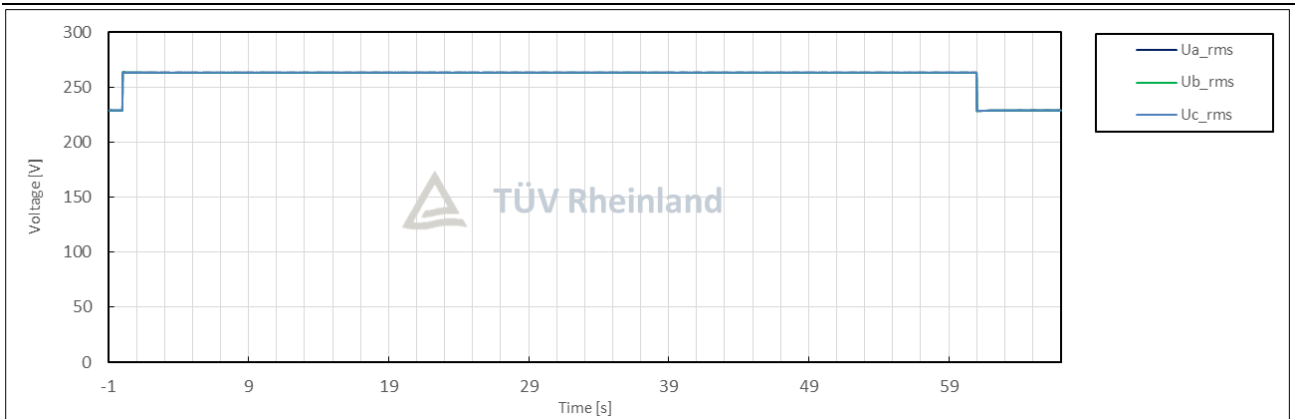
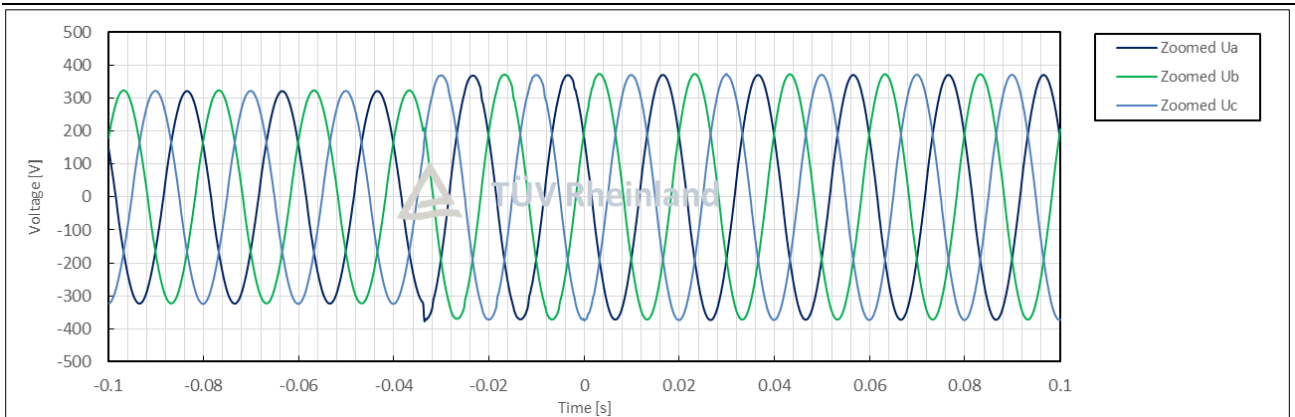
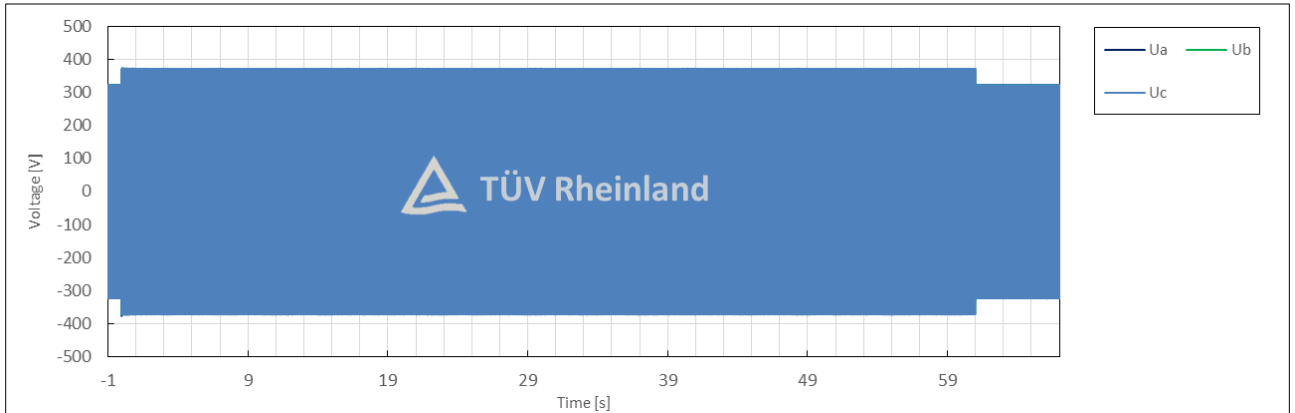

Test No. 7.1 with PGU

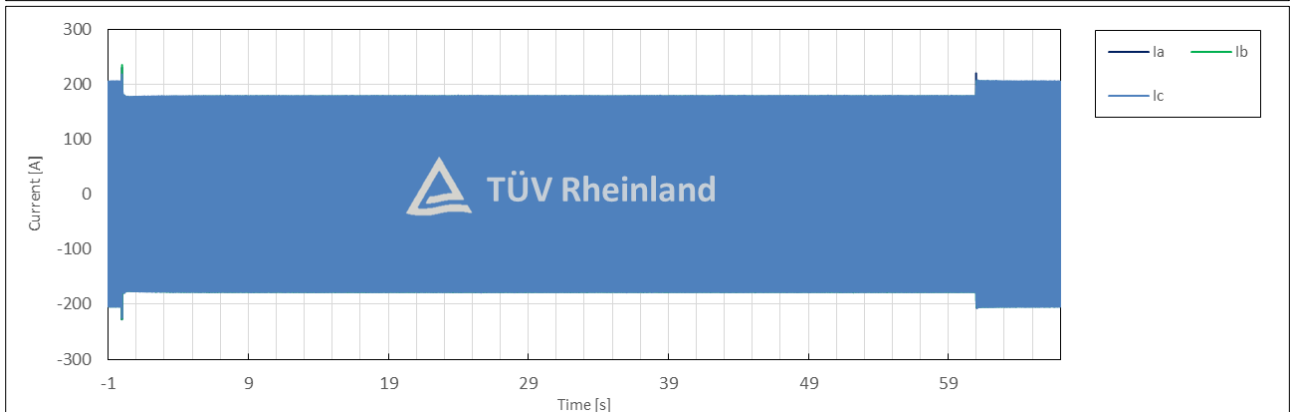
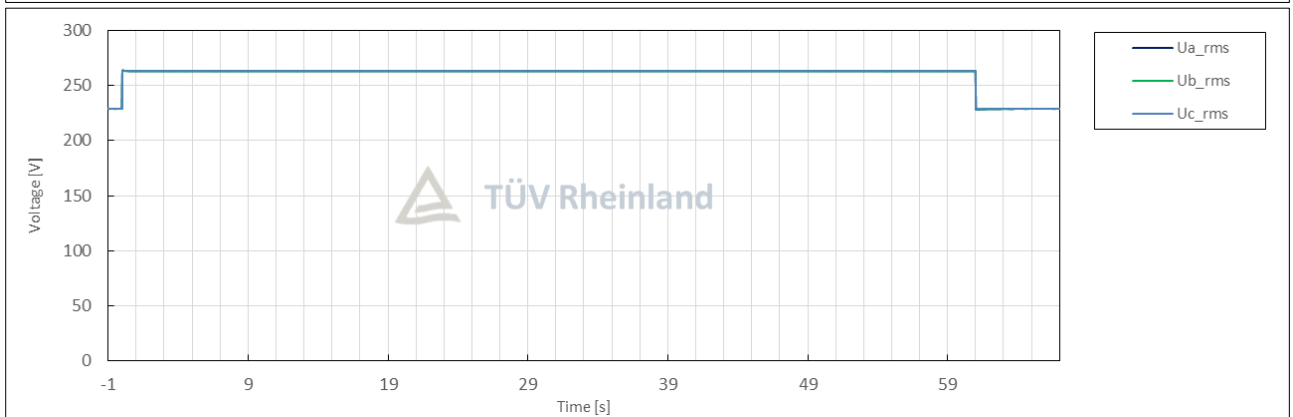
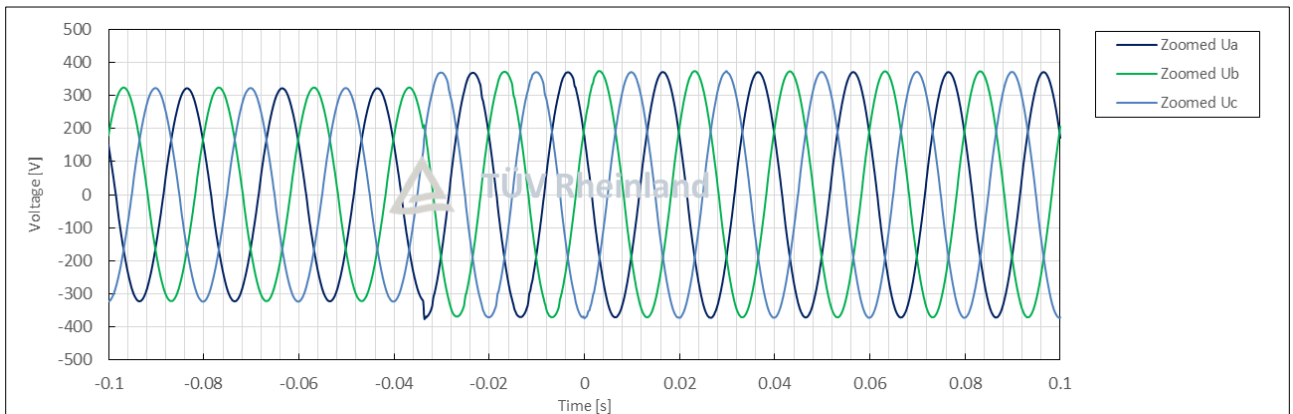
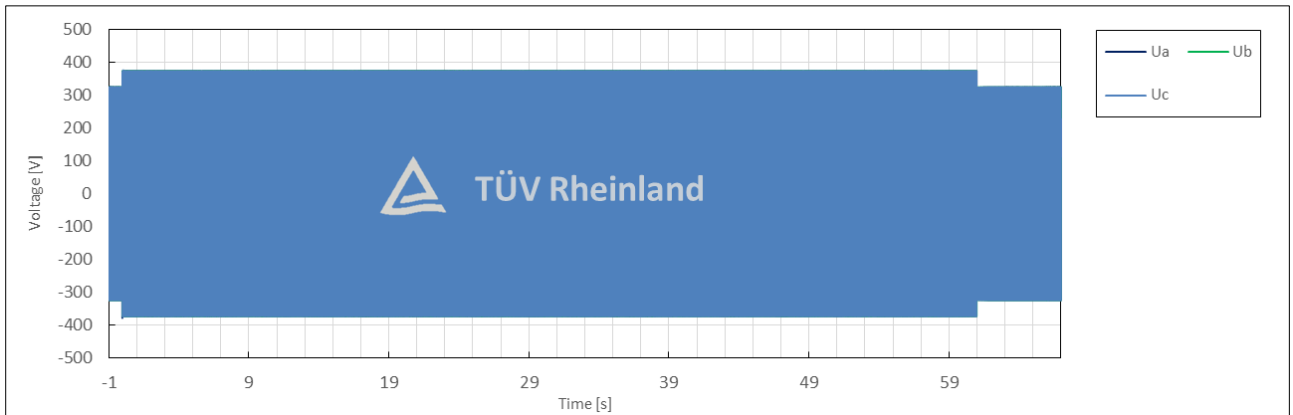

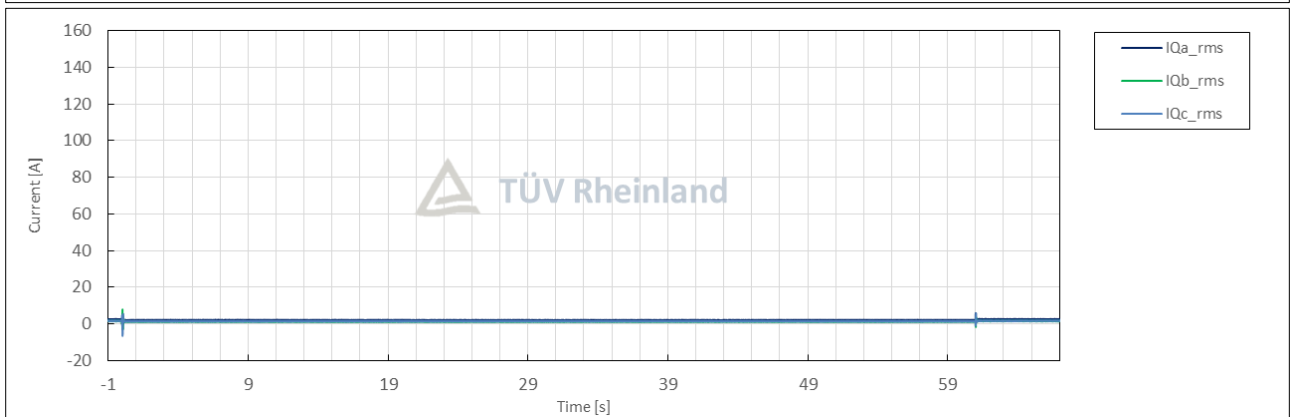
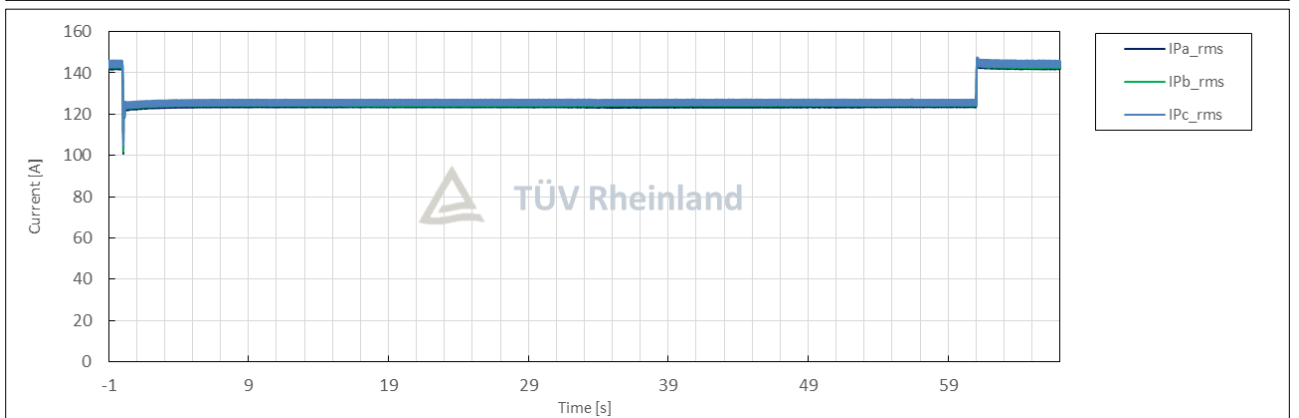
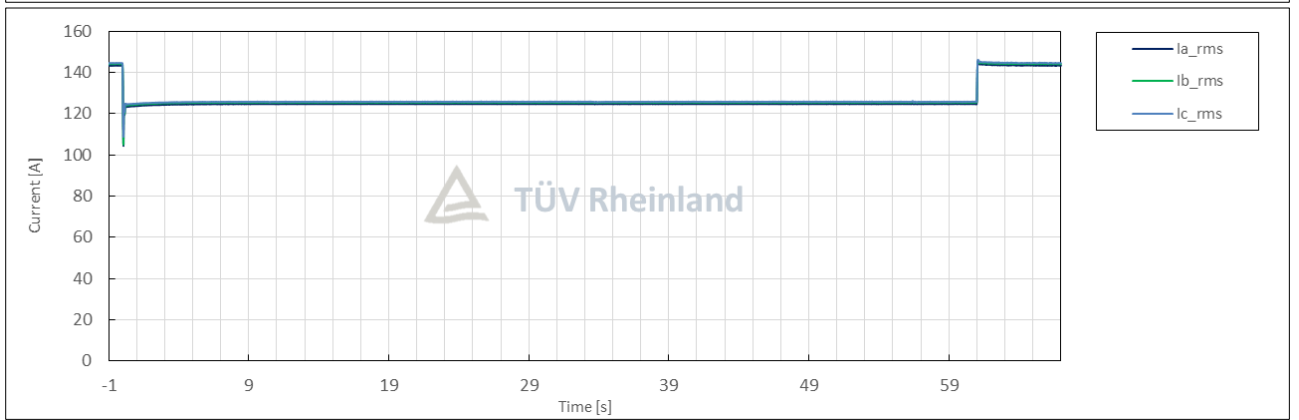
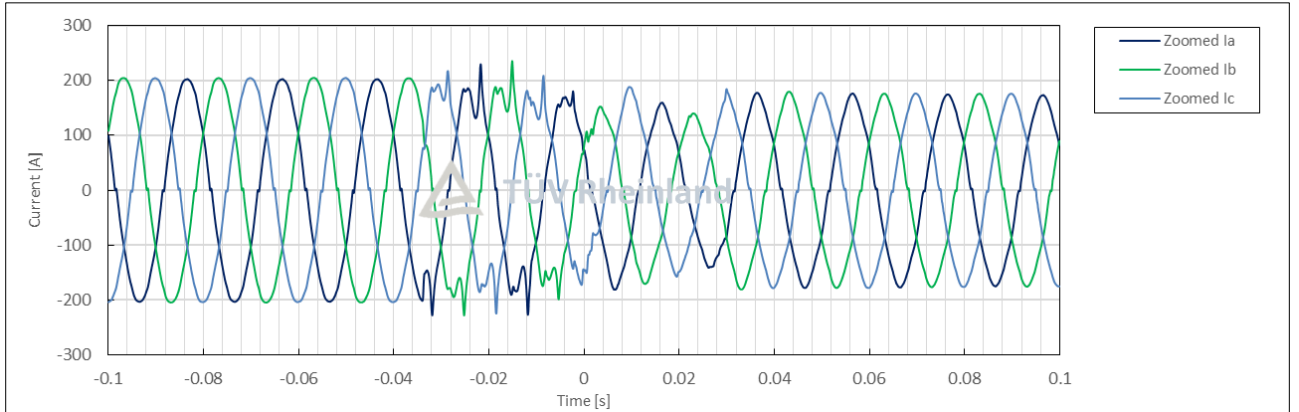

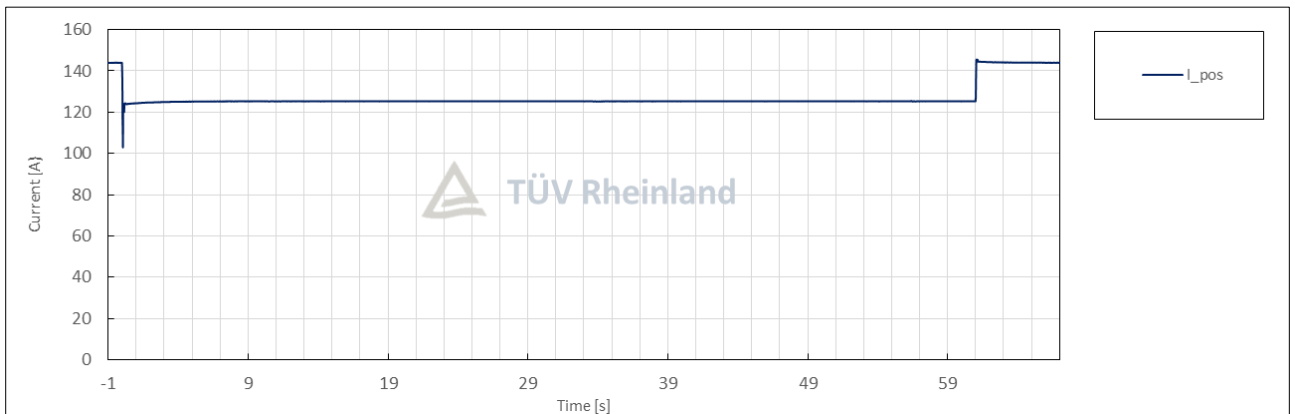
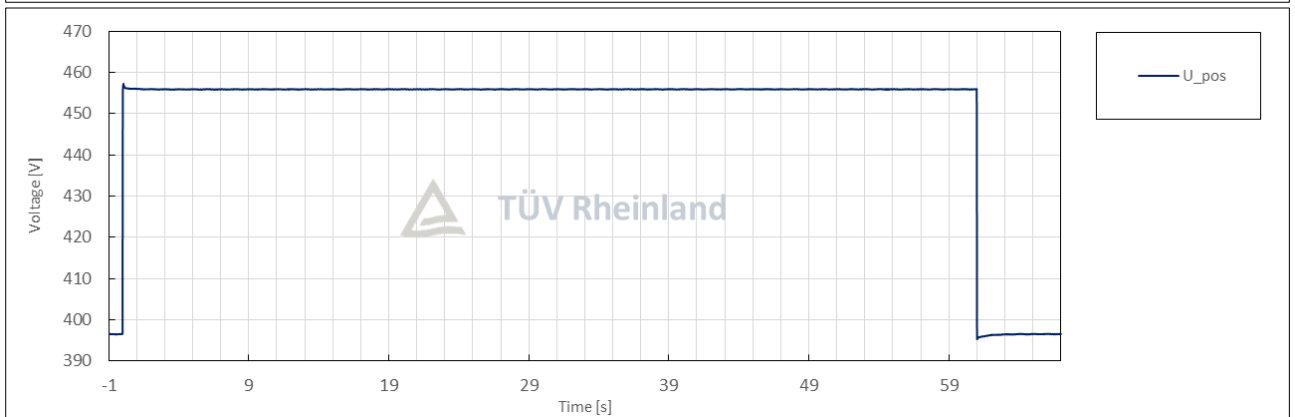
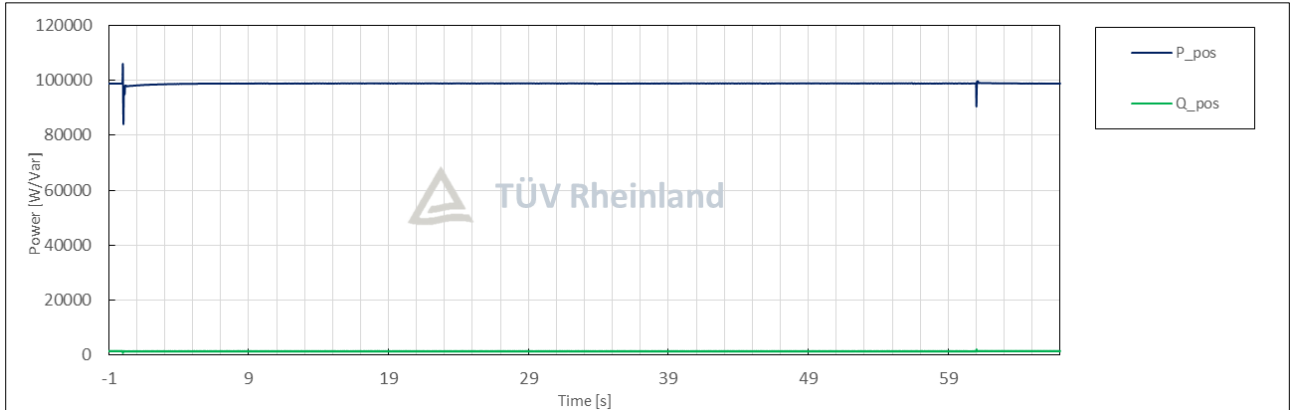

Condition						Measurement
No.	Parameter	Phase ref.	Time ref.	unit		
General Info.	0	Test number	--	--	--	7.2
	1	Date	--	--	dd.mm.yyyy	28.07.2025
	2	Time (start of test)	--	--	hh:mm:ss.f	13:55:31
	3	Fault type (phase)	--	--		3-phase fault
	4	Setting voltage depth	Line to line	--	p.u.	1.14
	5	Setting dip duration		--		61006
	6	Point of fault entry	Total	--	ms	0
	7	Point of fault clearance	Total	--	ms	61006
	8	Fault duration in empty load test	Total	--	ms	61006
	9	Voltage depth/height in empty load test	Total	t1+100ms to t2 and t1-10s to t1	p.u.	1.15
	10		Pos.		p.u.	1.15
Before dip <t1	11	Voltage	Line to neutral	t1-100s to t1	p.u.	1.00
	12	Current	Pos.	t1-500ms to t1-100ms	p.u.	0.30
	13	Active power	Total	t1-10s to t1	p.u.	0.30
	14		Pos.			0.30
	15	Reactive power	Total	t1-10s to t1	p.u.	0.00
	16		Pos.			0.00
17	Cos ϕ	--	t1-10s to t1	--	1.000	
During dip t1 to t2	18	Voltage	Line to neutral	t1+100ms to t2-20ms	p.u.	1.14
	19	Line current	Phase 1	t1+60ms	p.u.	0.26
	20		Phase 2			0.26
	21		Phase 3			0.26
	22	Line current	Phase 1	t1+100ms	p.u.	0.26
	23		Phase 2			0.26
	24		Phase 3			0.26
	25	Active power	Total	t1+100ms to t2-20ms	p.u.	0.30
26	Pos.		0.30			
After dip > t2	27	Voltage	Line to neutral	t2+3s to t2+10s	p.u.	0.99
	28	Active power	Total	t2+3s to t2+10s	p.u.	0.30
	29		Pos.			0.30
	39	Active power rising time	Pos.	--	s	N/A
	31	Reactive power	Total	t2+3s to t2+10s	p.u.	0.00
	32		Pos.			0.00
	33	Reactive power rising time	Pos.	--	s	N/A
34	PGU does not disconnect from grid till 60s after fault	--	t2 to t2+60s	Yes / No	No	

Test No. 7.2 idle test

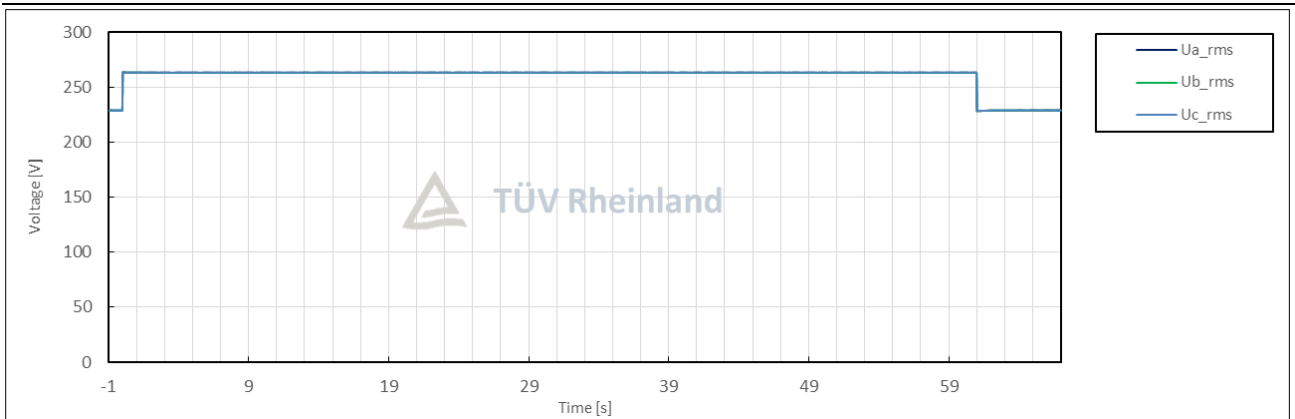
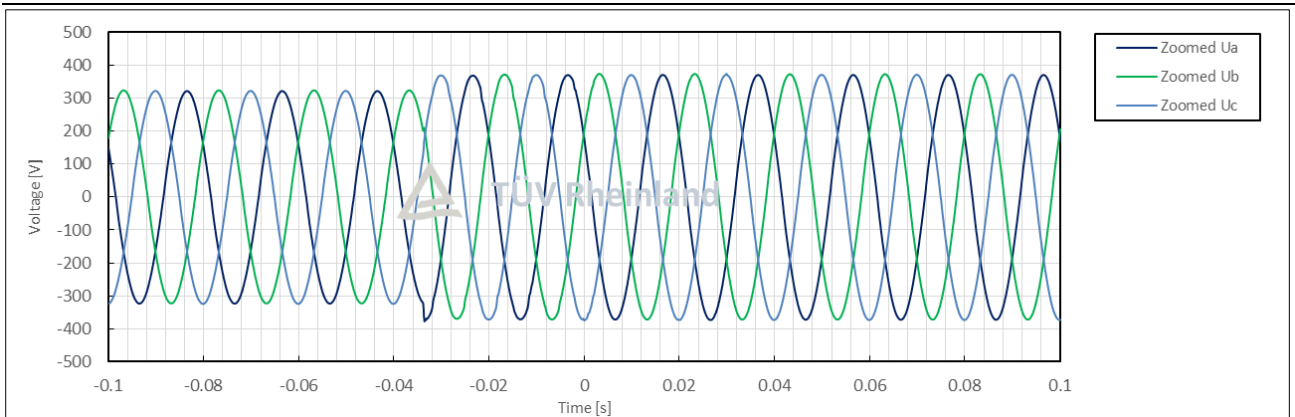
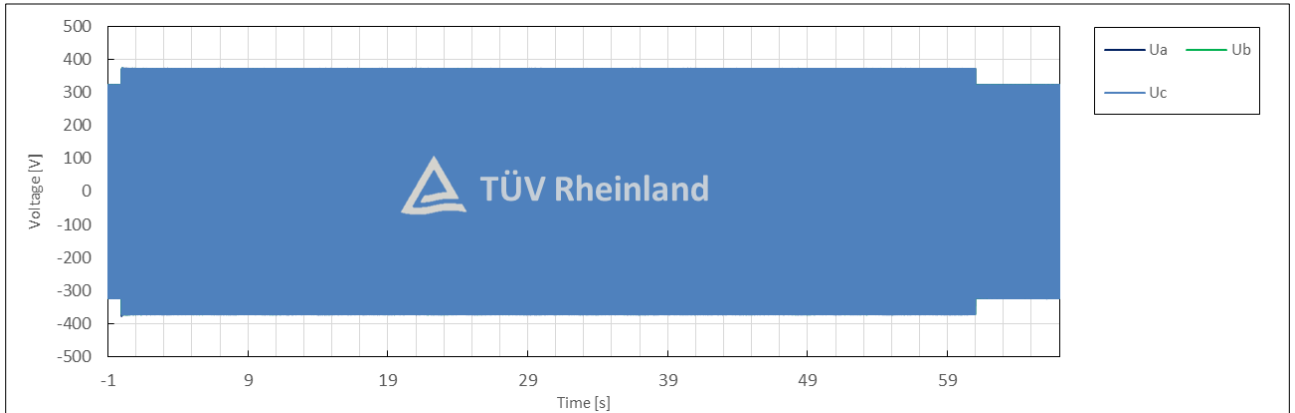

Test No. 7.2 with PGU

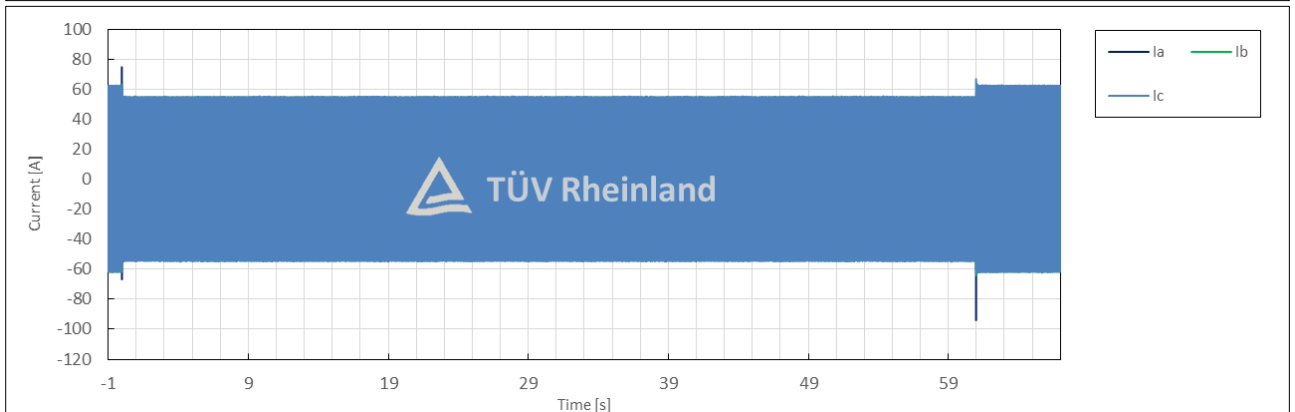
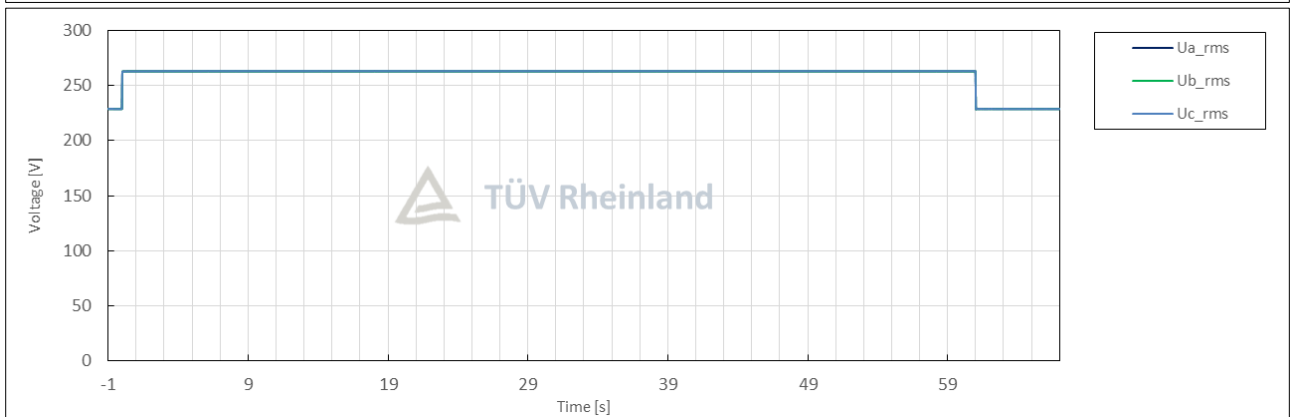
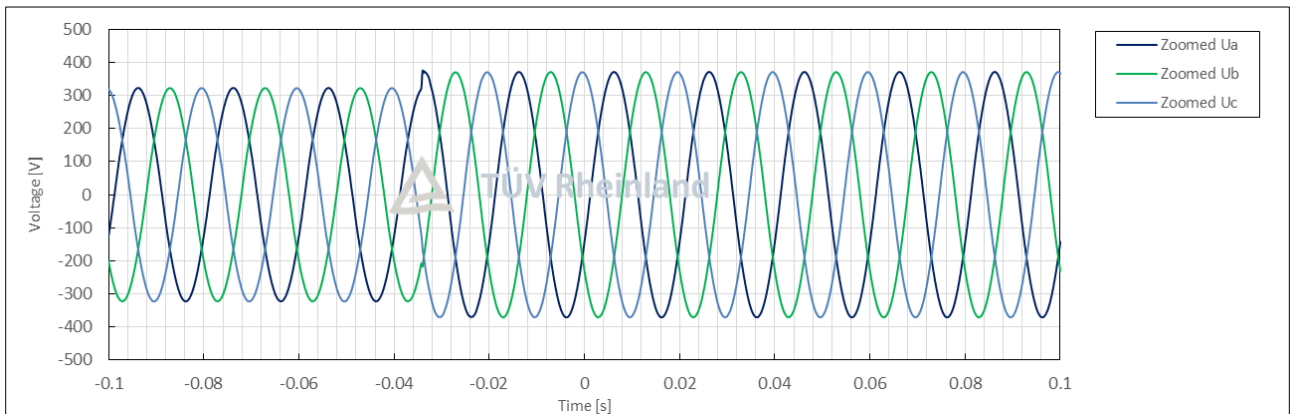
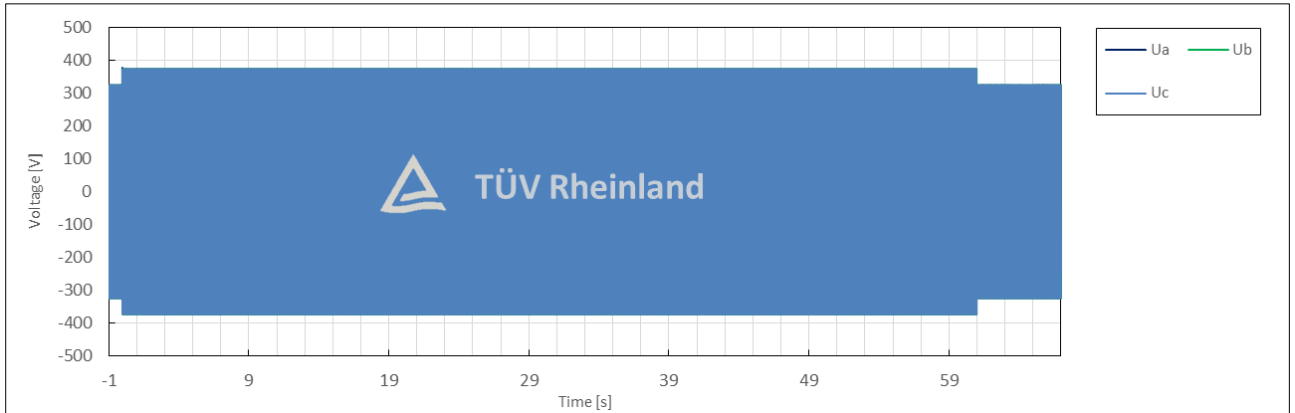

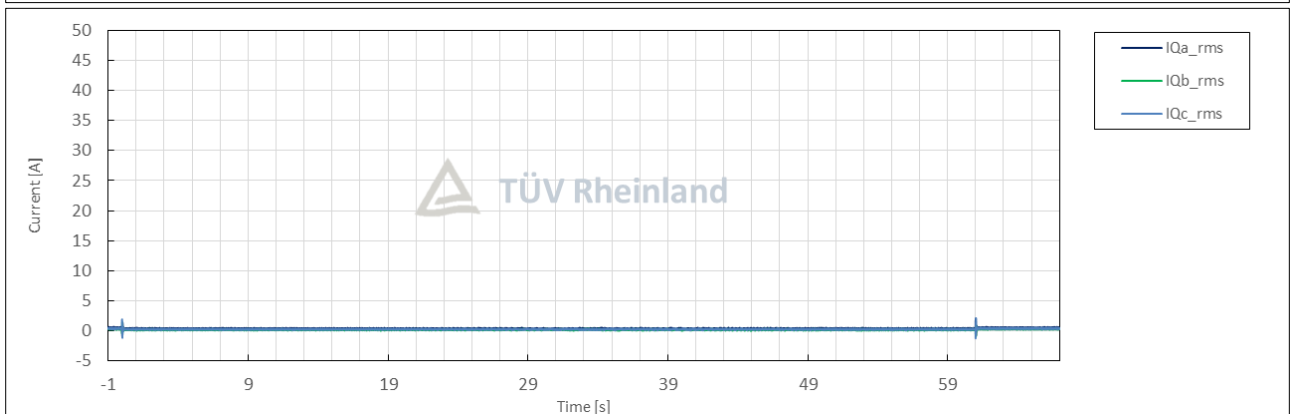
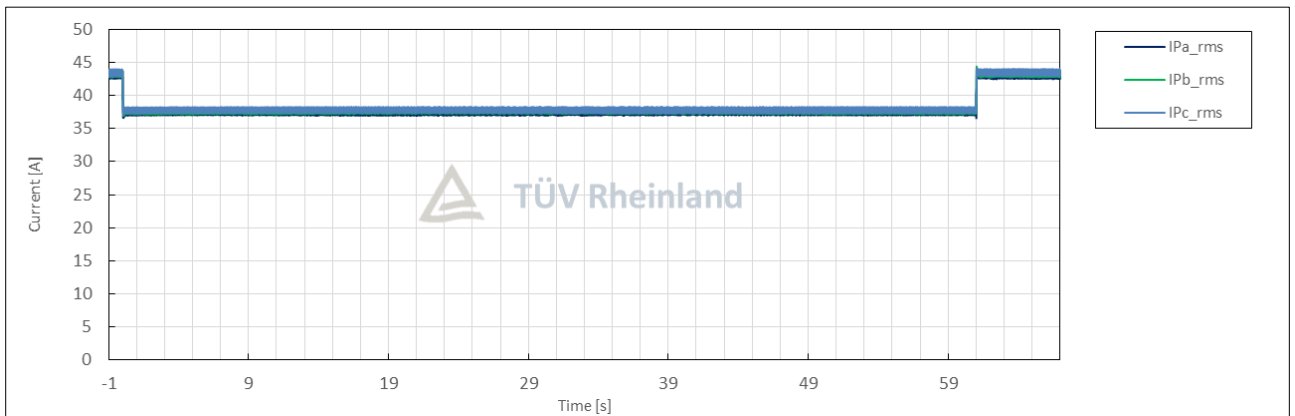
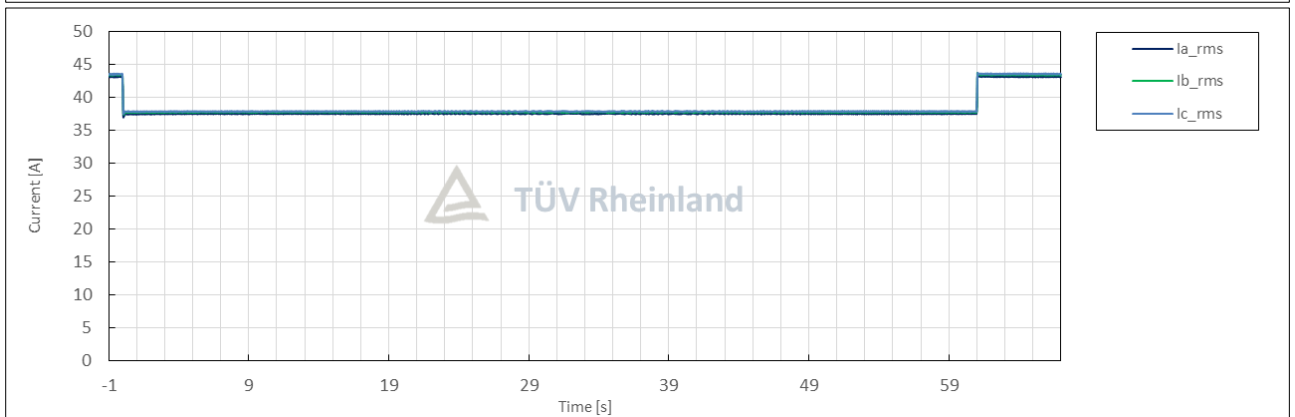
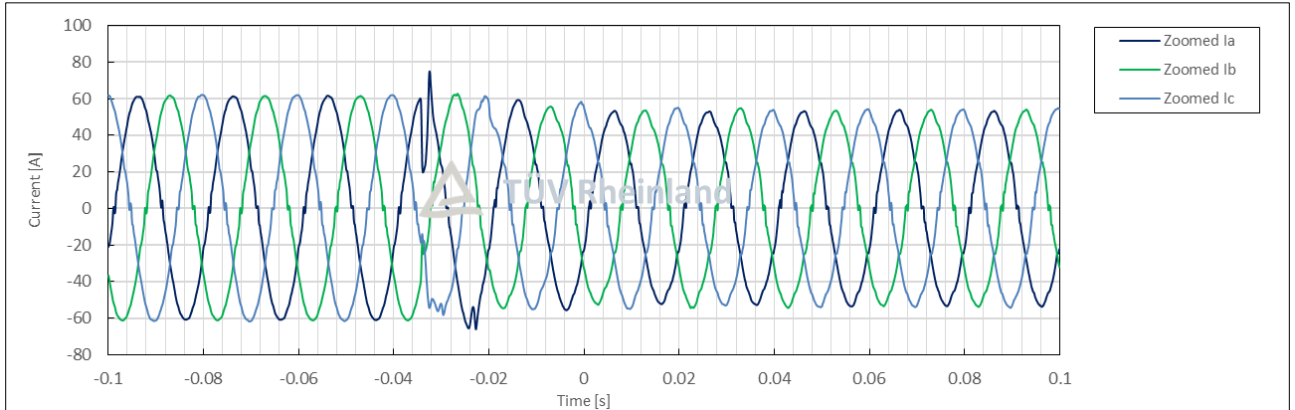

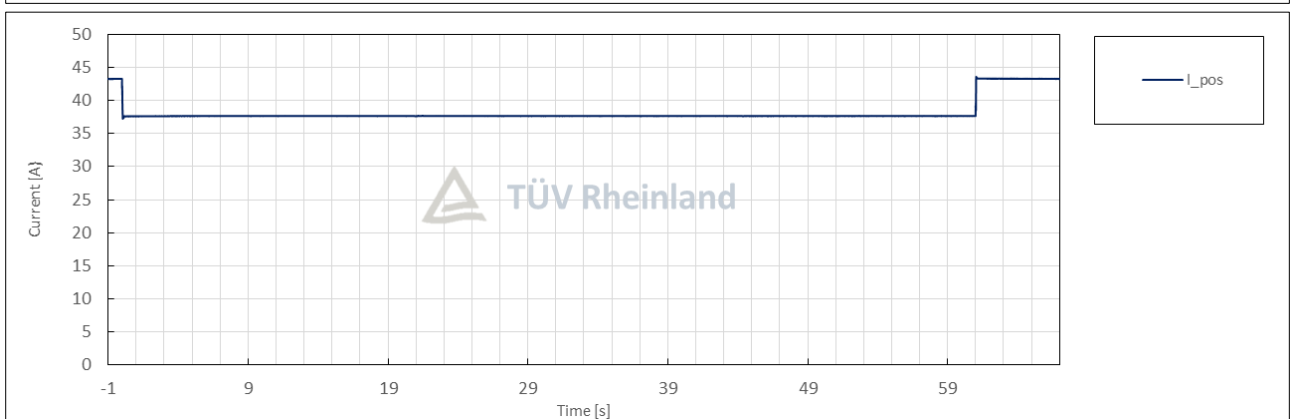
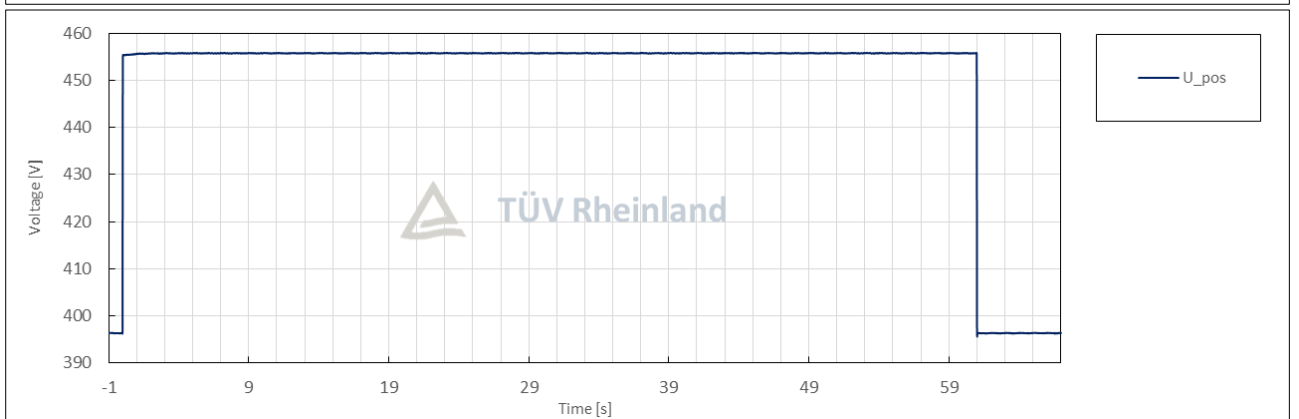
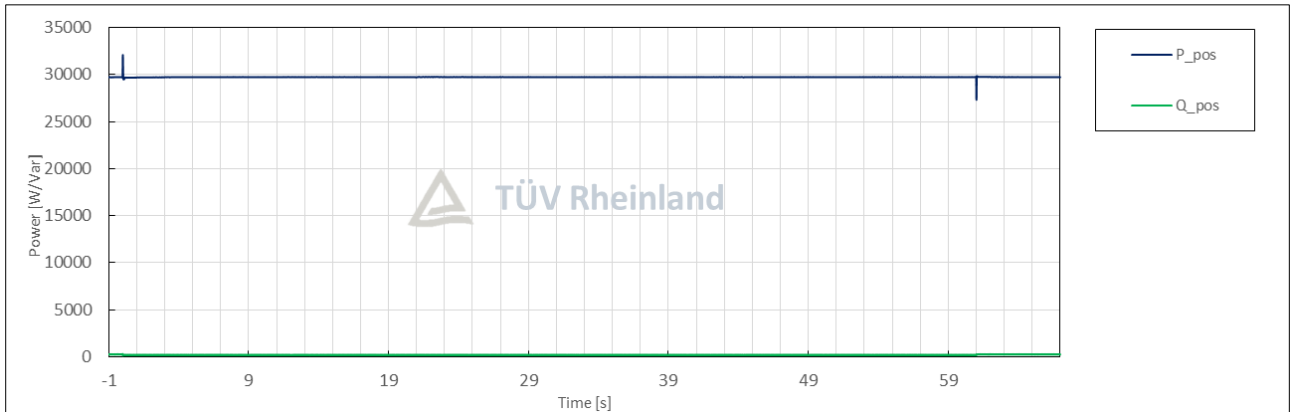

Condition						Measurement
No.	Parameter	Phase ref.	Time ref.	unit		
General Info.	0	Test number	--	--	--	7.3
	1	Date	--	--	dd.mm.yyyy	28.07.2025
	2	Time (start of test)	--	--	hh:mm:ss.f	13:56:00
	3	Fault type (phase)	--	--		2-phase fault
	4	Setting voltage depth	Line to line	--	p.u.	1.14
	5	Setting dip duration		--		61003
	6	Point of fault entry	Total	--	ms	0
	7	Point of fault clearance	Total	--	ms	61003
	8	Fault duration in empty load test	Total	--	ms	61003
	9	Voltage depth/height in empty load test	Total	t1+100ms to t2 and t1-10s to t1	p.u.	1.15
10	Pos.		p.u.		1.08	
Before dip <t1	11	Voltage	Line to neutral	t1-100s to t1	p.u.	1.00
	12	Current	Pos.	t1-500ms to t1-100ms	p.u.	0.99
	13	Active power	Total	t1-10s to t1	p.u.	0.99
	14		Pos.			0.99
	15	Reactive power	Total	t1-10s to t1	p.u.	0.01
	16		Pos.			0.01
17	Cos ϕ	--	t1-10s to t1	--	1.000	
During dip t1 to t2	18	Voltage	Line to neutral	t1+100ms to t2-20ms	p.u.	1.14
	19	Line current	Phase 1	t1+60ms	p.u.	0.95
	20		Phase 2			0.86
	21		Phase 3			0.95
	22	Line current	Phase 1	t1+100ms	p.u.	0.95
	23		Phase 2			0.86
	24		Phase 3			0.96
	25	Active power	Total	t1+100ms to t2-20ms	p.u.	0.99
26	Pos.		0.99			
After dip > t2	27	Voltage	Line to neutral	t2+3s to t2+10s	p.u.	1.00
	28	Active power	Total	t2+3s to t2+10s	p.u.	0.99
	29		Pos.			0.99
	39	Active power rising time	Pos.	--	s	N/A
	31	Reactive power	Total	t2+3s to t2+10s	p.u.	0.01
	32		Pos.			0.01
	33	Reactive power rising time	Pos.	--	s	N/A
34	PGU does not disconnect from grid till 60s after fault	--	t2 to t2+60s	Yes / No	No	

Test No. 7.3 idle test

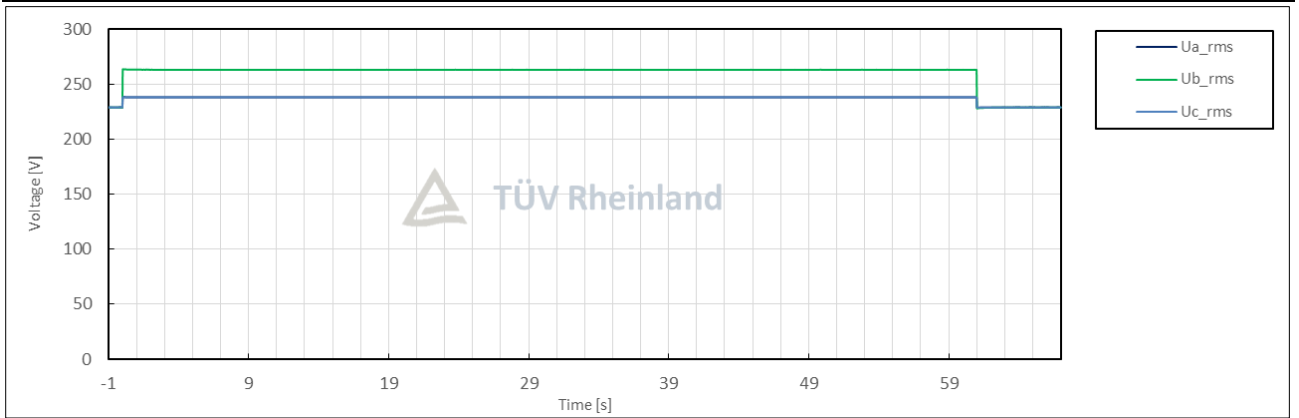
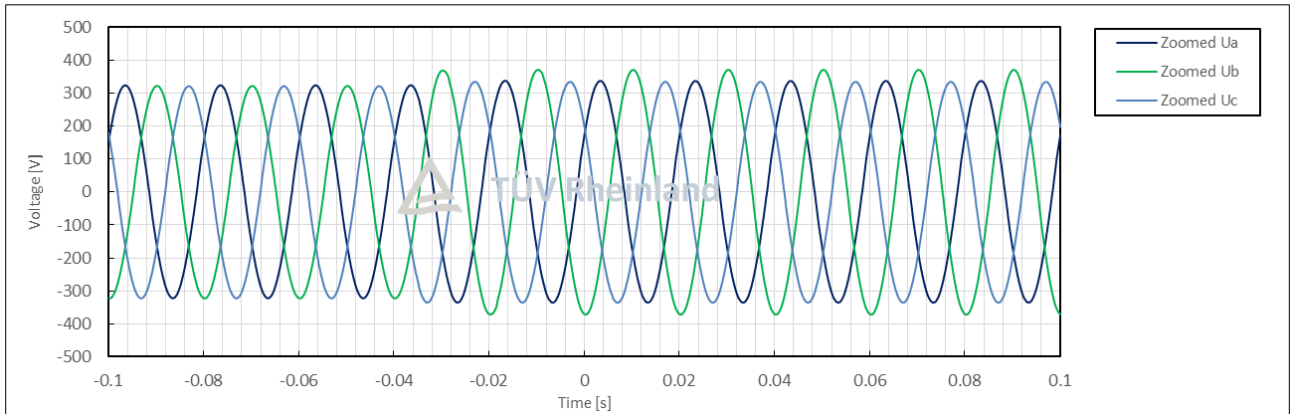
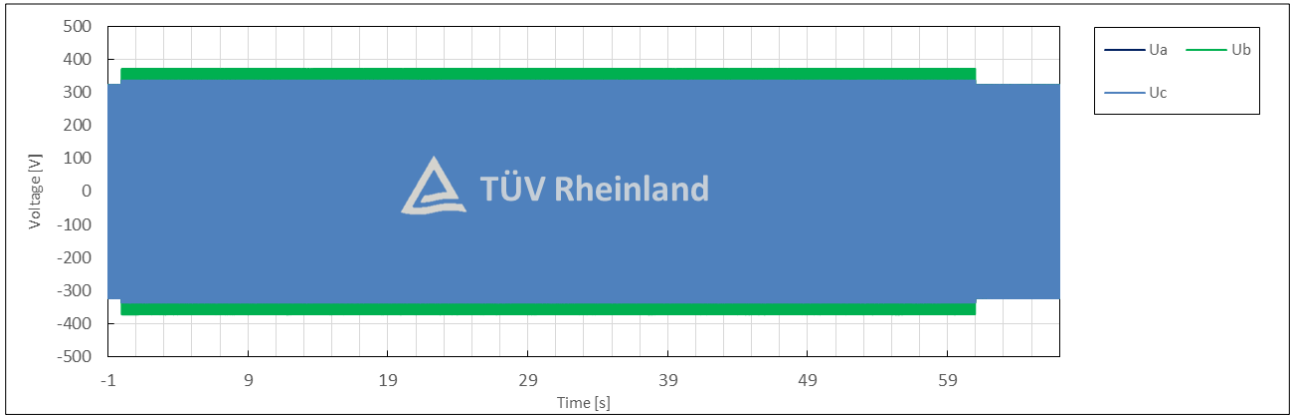

Test No. 7.3 with PGU

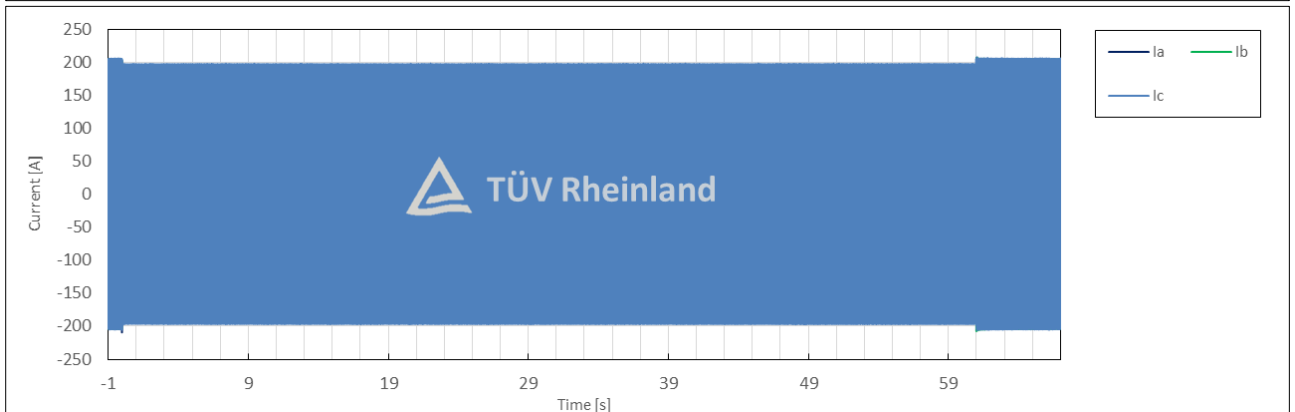
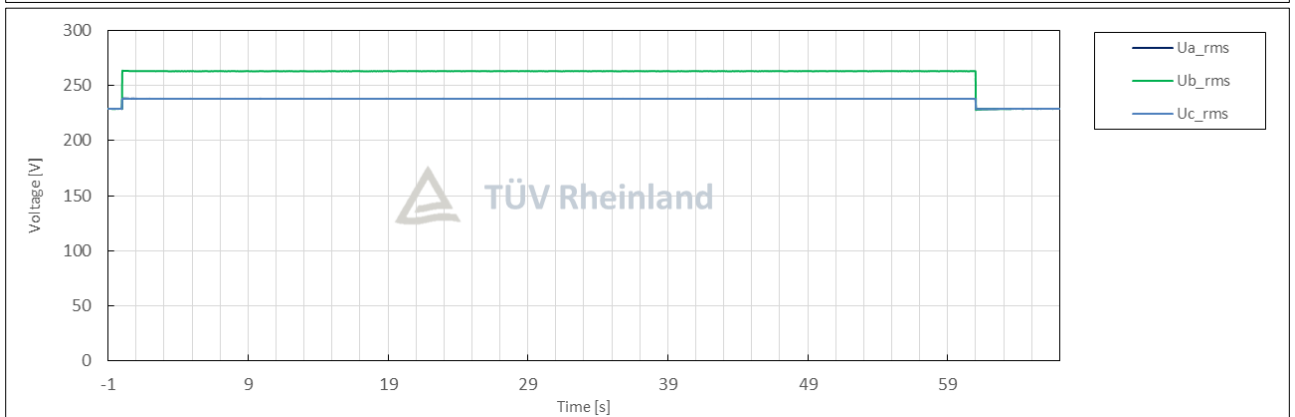
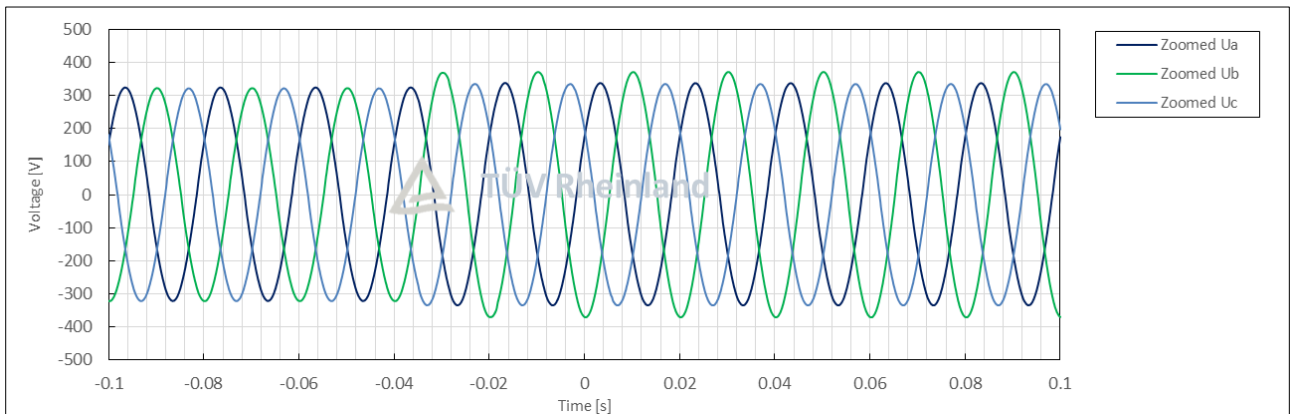
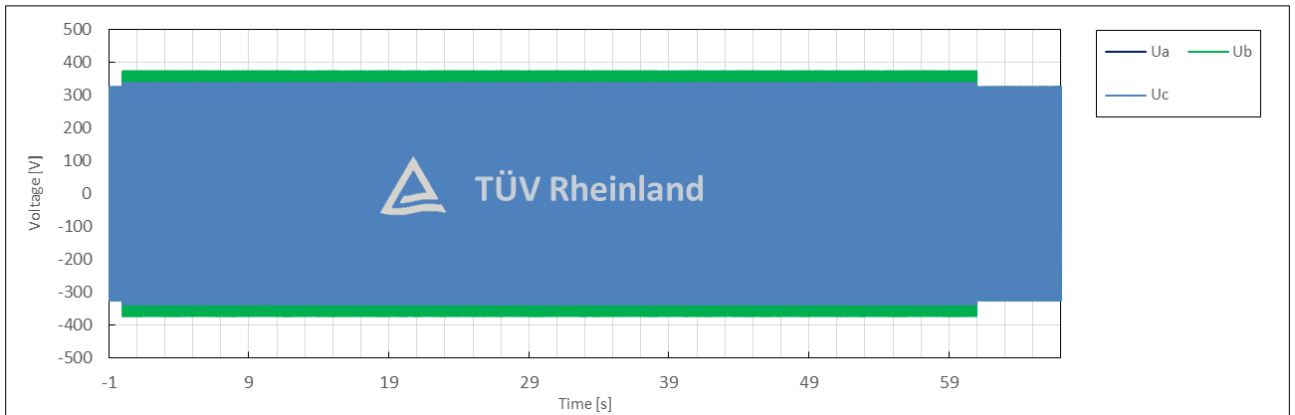

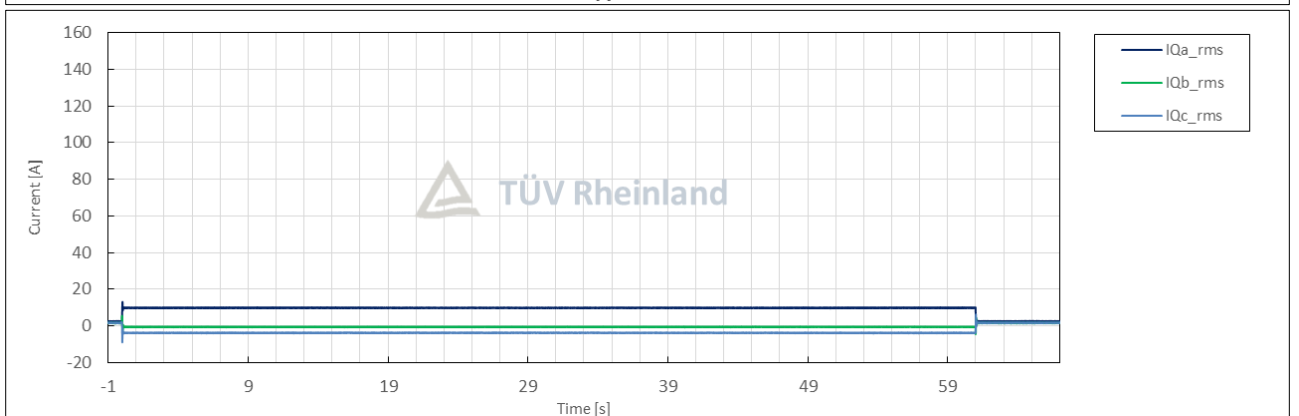
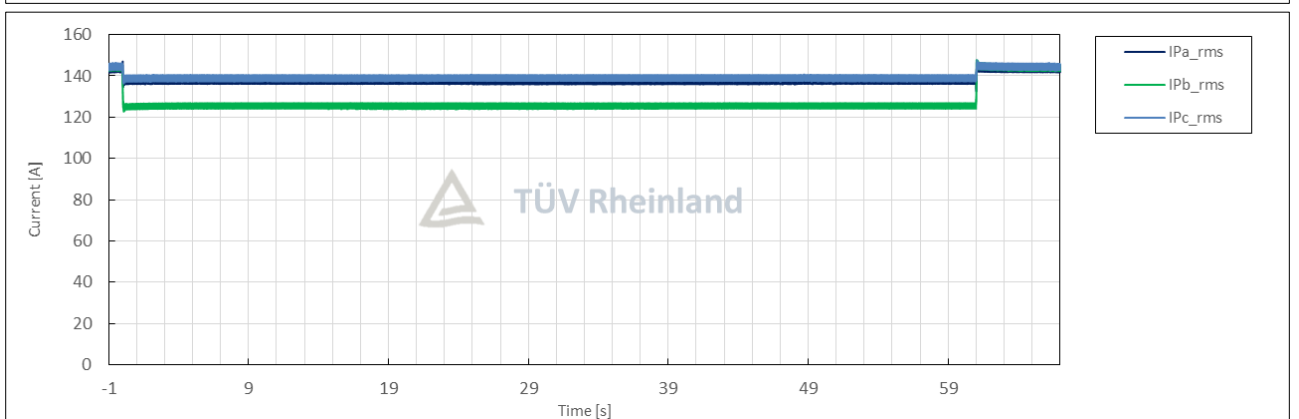
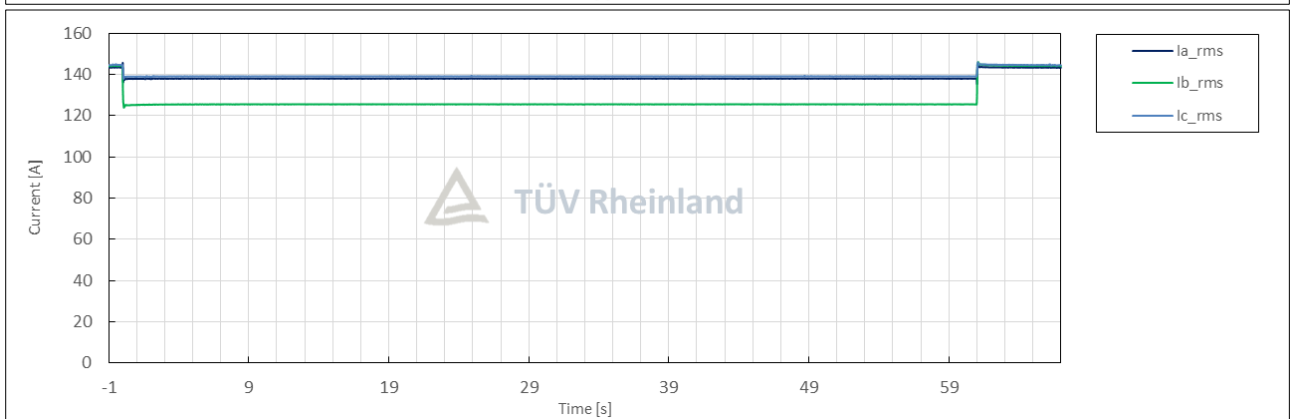
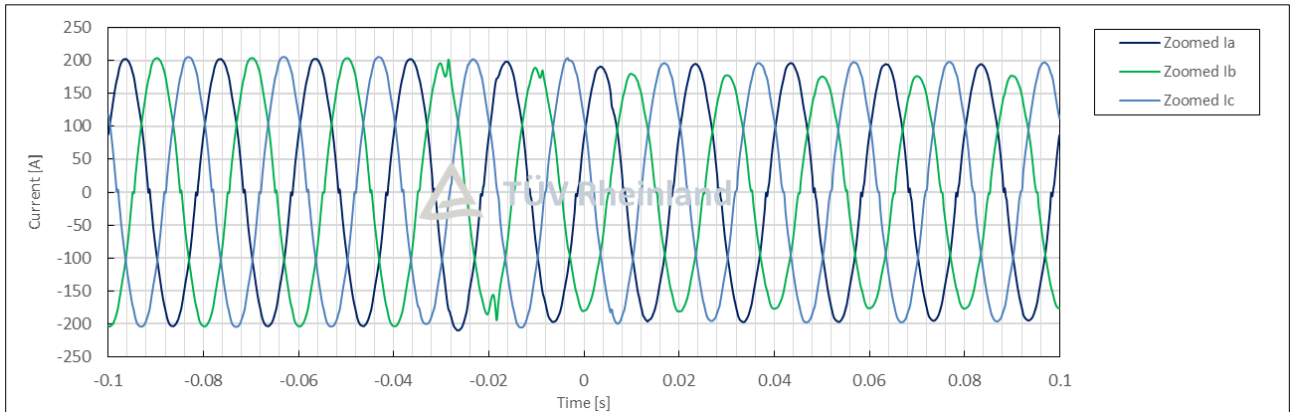

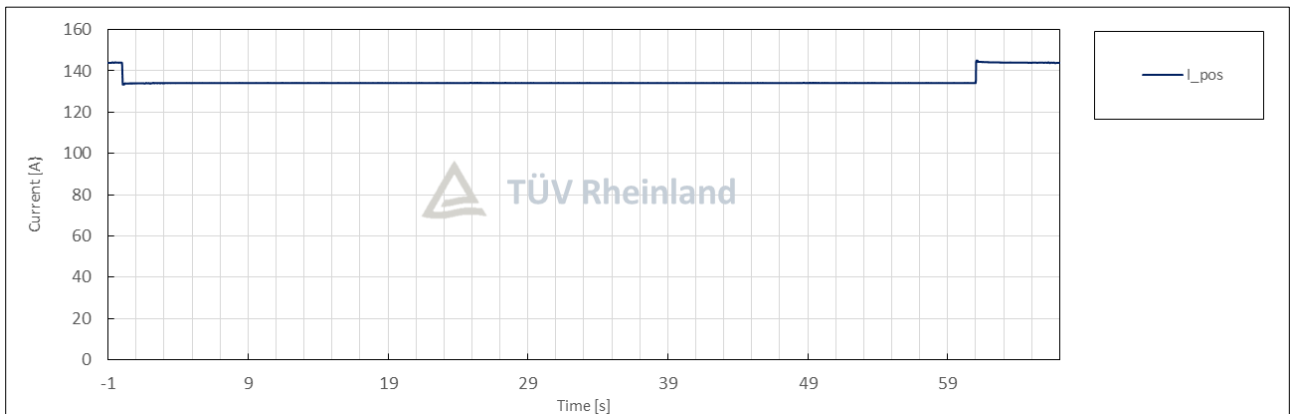
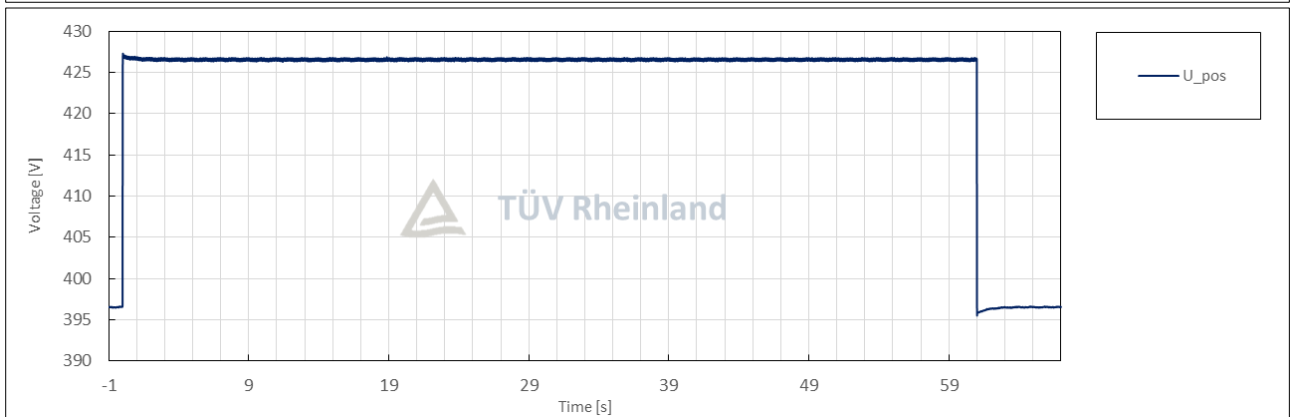
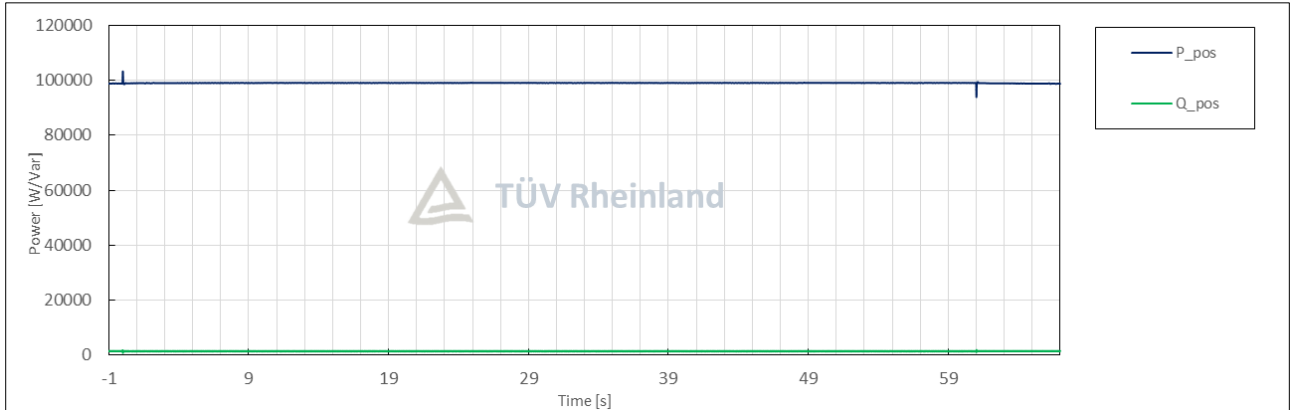

Condition						Measurement
No.	Parameter	Phase ref.	Time ref.	unit		
General Info.	0	Test number	--	--	--	7.4
	1	Date	--	--	dd.mm.yyyy	28.07.2025
	2	Time (start of test)	--	--	hh:mm:ss.f	13:56:10
	3	Fault type (phase)	--	--		2-phase fault
	4	Setting voltage depth	Line to line	--	p.u.	1.14
	5	Setting dip duration		--		61003
	6	Point of fault entry	Total	--	ms	0
	7	Point of fault clearance	Total	--	ms	61003
	8	Fault duration in empty load test	Total	--	ms	61003
	9	Voltage depth/height in empty load test	Total	t1+100ms to t2 and t1-10s to t1	p.u.	1.15
10	Pos.		p.u.		1.08	
Before dip <t1	11	Voltage	Line to neutral	t1-100s to t1	p.u.	1.00
	12	Current	Pos.	t1-500ms to t1-100ms	p.u.	0.30
	13	Active power	Total	t1-10s to t1	p.u.	0.30
	14		Pos.			0.30
	15	Reactive power	Total	t1-10s to t1	p.u.	0.00
	16		Pos.			0.00
17	Cos ϕ	--	t1-10s to t1	--	1.000	
During dip t1 to t2	18	Voltage	Line to neutral	t1+100ms to t2-20ms	p.u.	1.14
	19	Line current	Phase 1	t1+60ms	p.u.	0.29
	20		Phase 2			0.26
	21		Phase 3			0.29
	22	Line current	Phase 1	t1+100ms	p.u.	0.29
	23		Phase 2			0.26
	24		Phase 3			0.29
	25	Active power	Total	t1+100ms to t2-20ms	p.u.	0.30
26	Pos.		0.30			
After dip > t2	27	Voltage	Line to neutral	t2+3s to t2+10s	p.u.	0.99
	28	Active power	Total	t2+3s to t2+10s	p.u.	0.30
	29		Pos.			0.30
	39	Active power rising time	Pos.	--	s	N/A
	31	Reactive power	Total	t2+3s to t2+10s	p.u.	0.00
	32		Pos.			0.00
	33	Reactive power rising time	Pos.	--	s	N/A
34	PGU does not disconnect from grid till 60s after fault	--	t2 to t2+60s	Yes / No	No	

Test No. 7.4 idle test

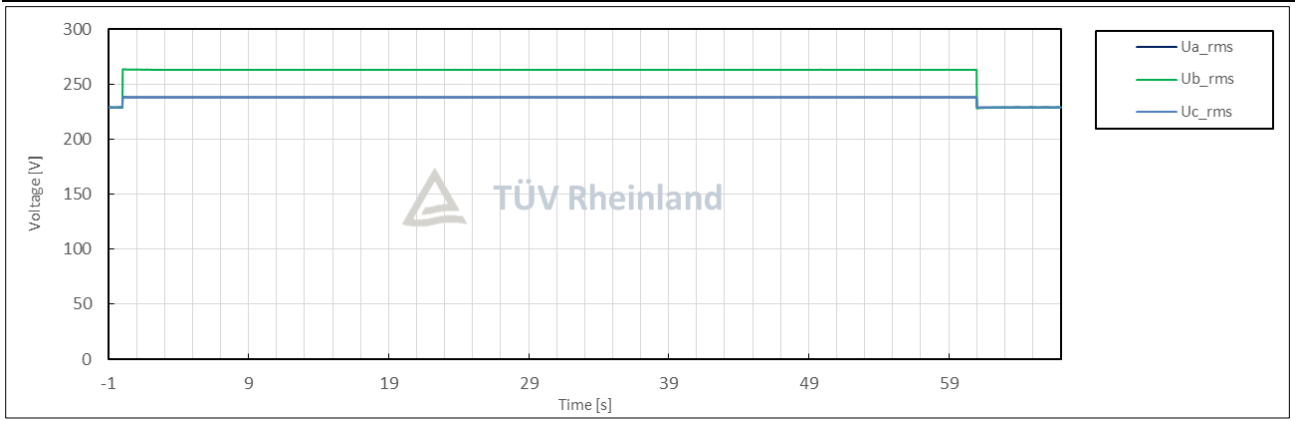
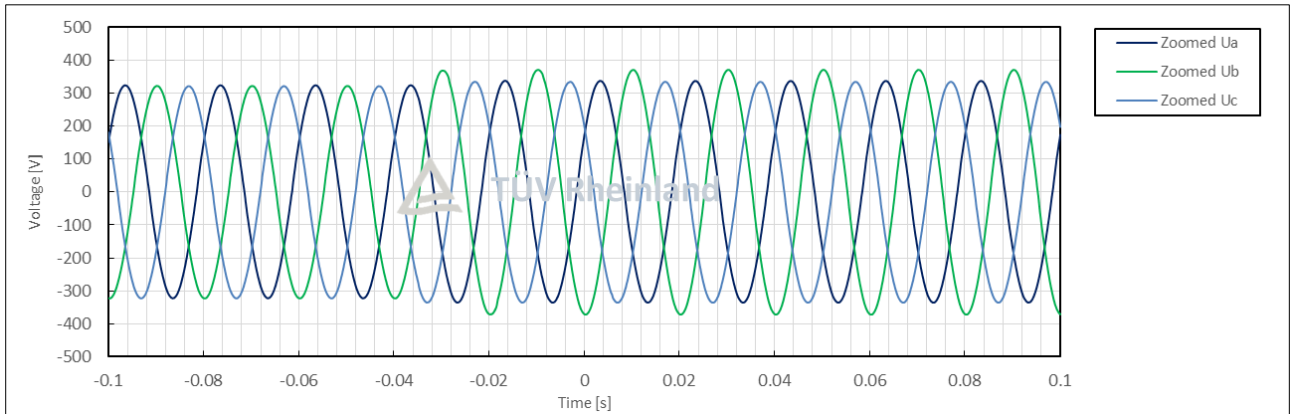
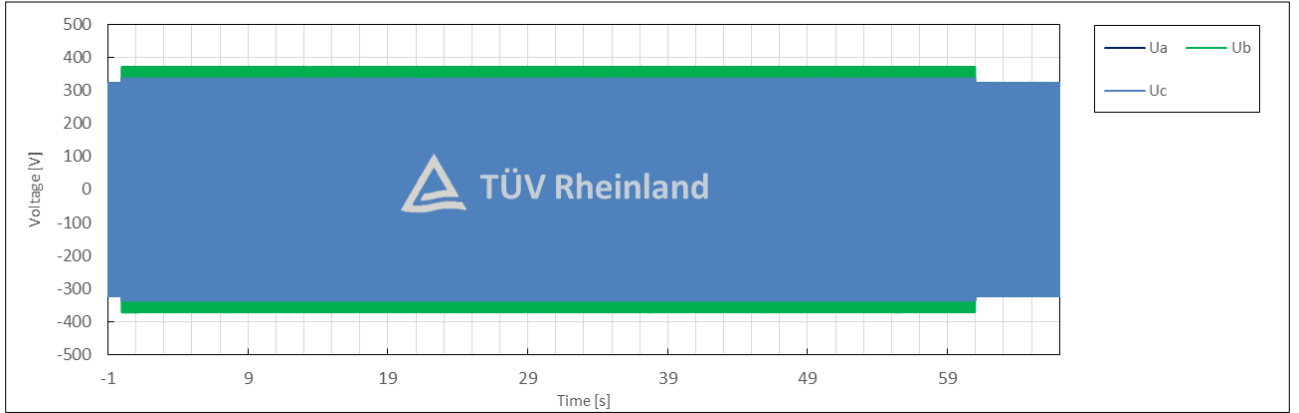

Test No. 7.4 with PGU

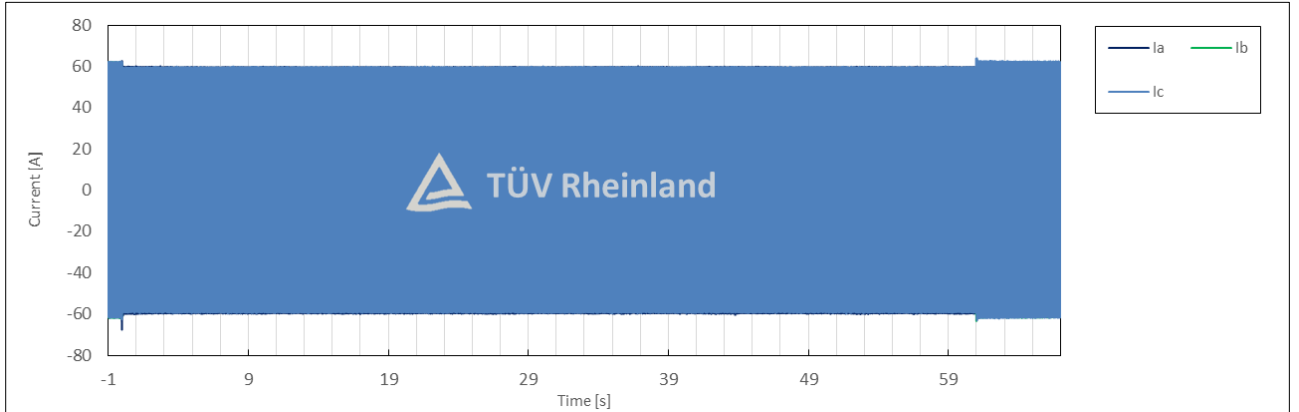
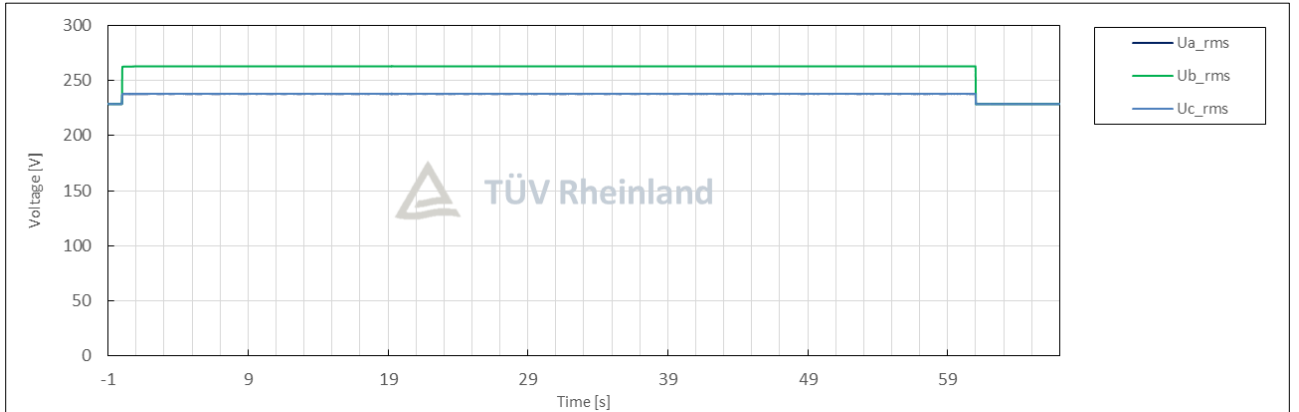
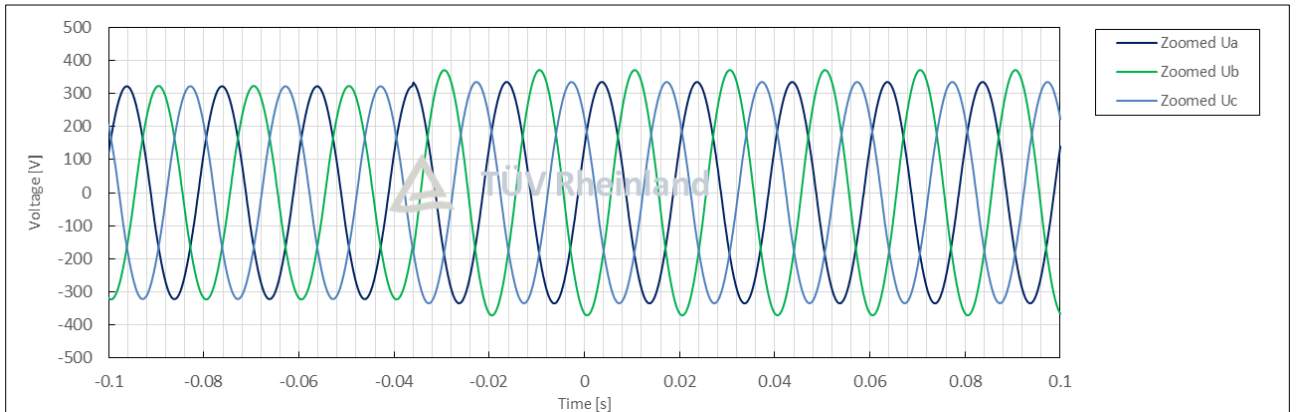
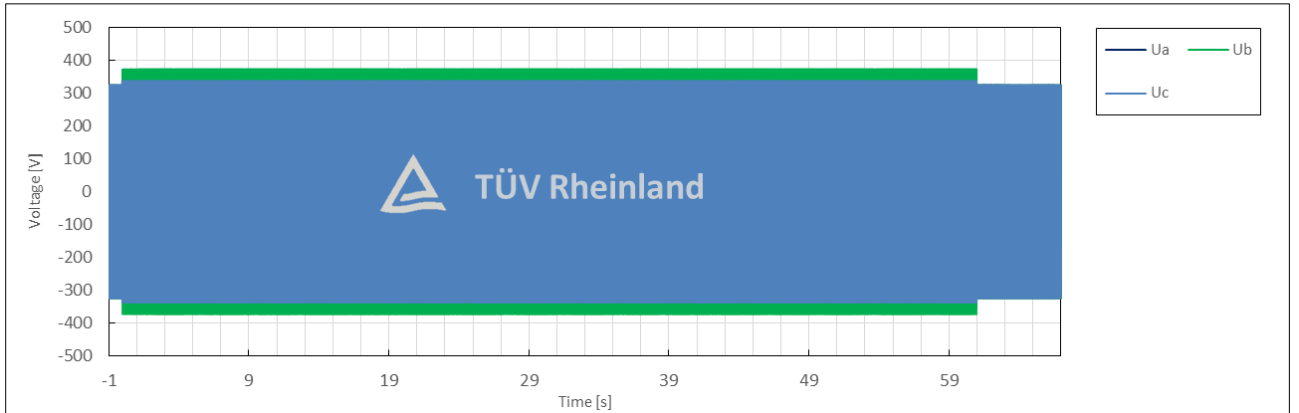

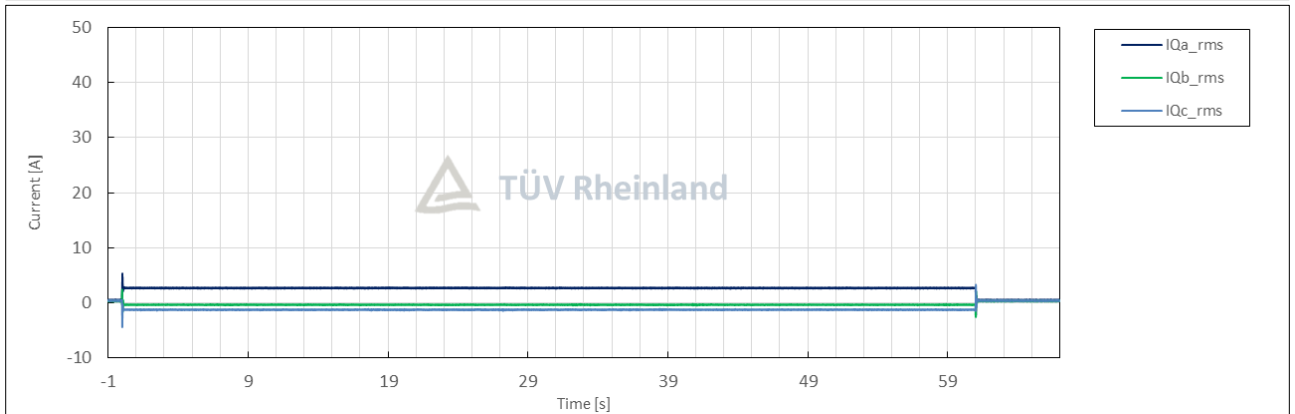
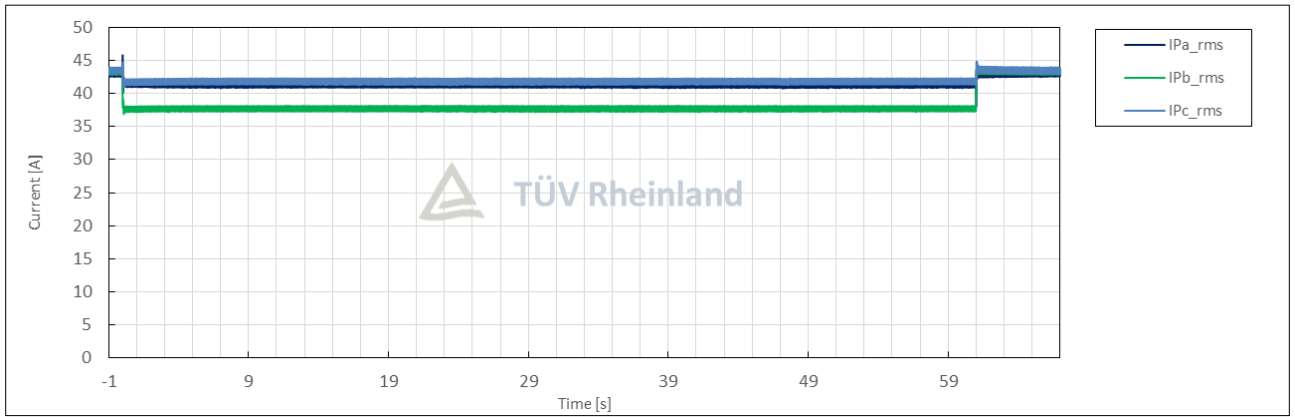
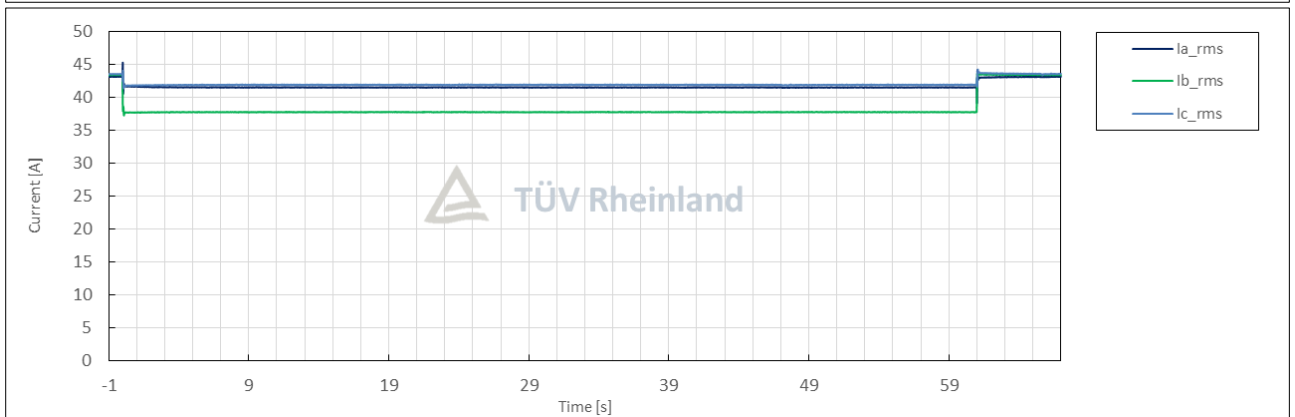
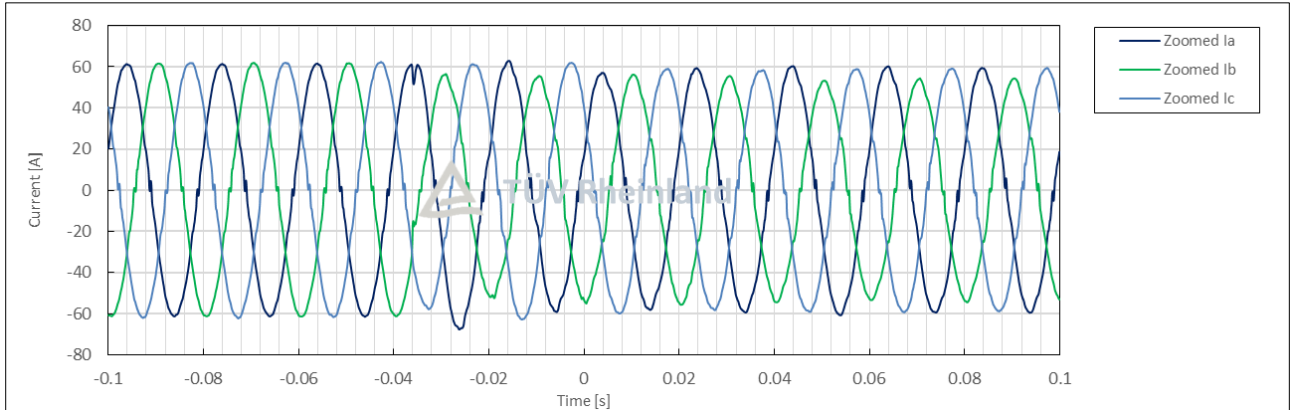

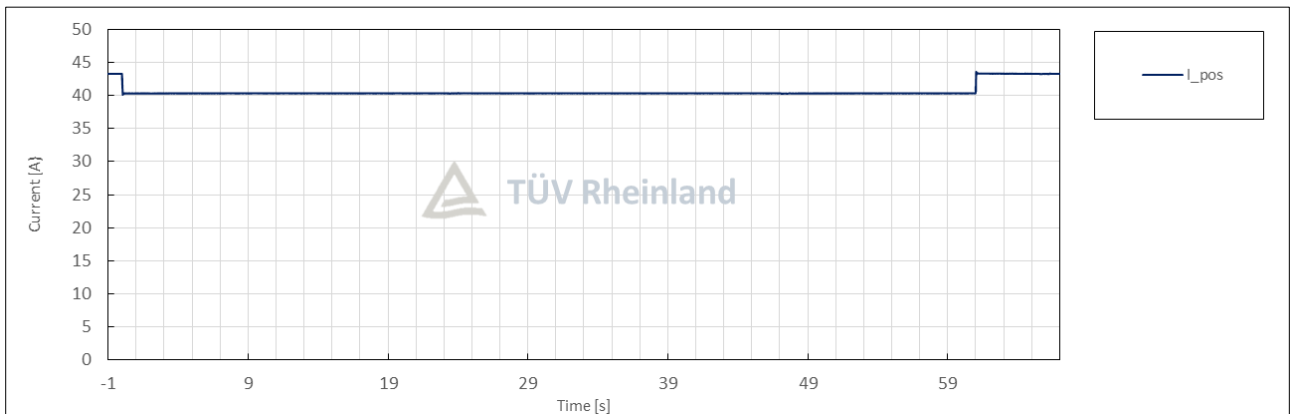
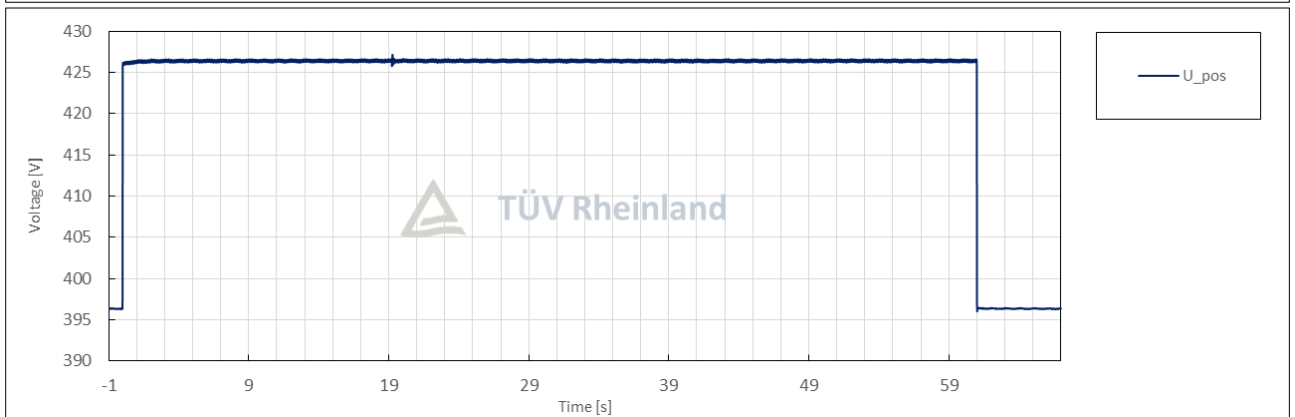
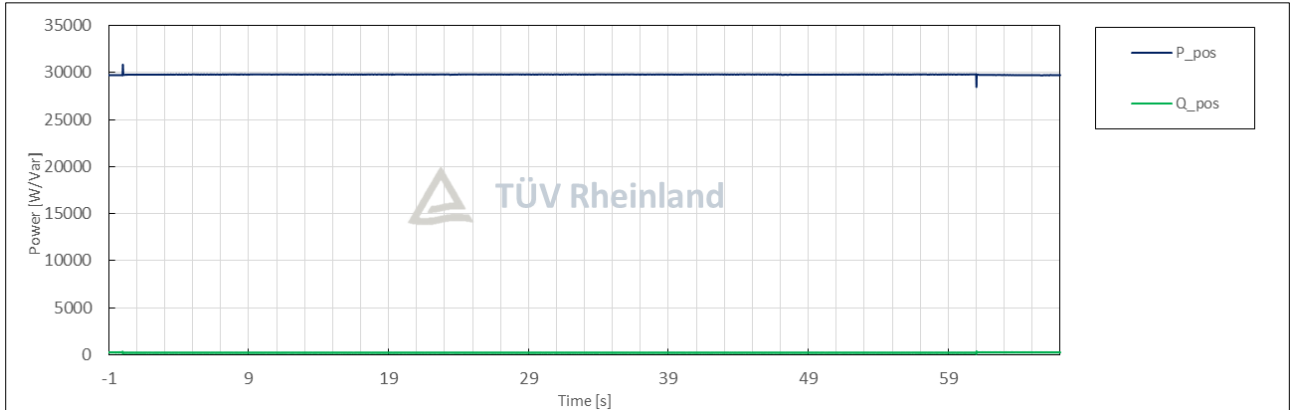

-End of attachment 1-



PHOTO DOCUMENTATION

CN25J408 002 Attachment 2

for

Hybrid Inverter

FINV-100-1-DAH

FENECON GmbH



This documentation consists of 5 pages (excluding this cover page)



Figure 1 The front side view

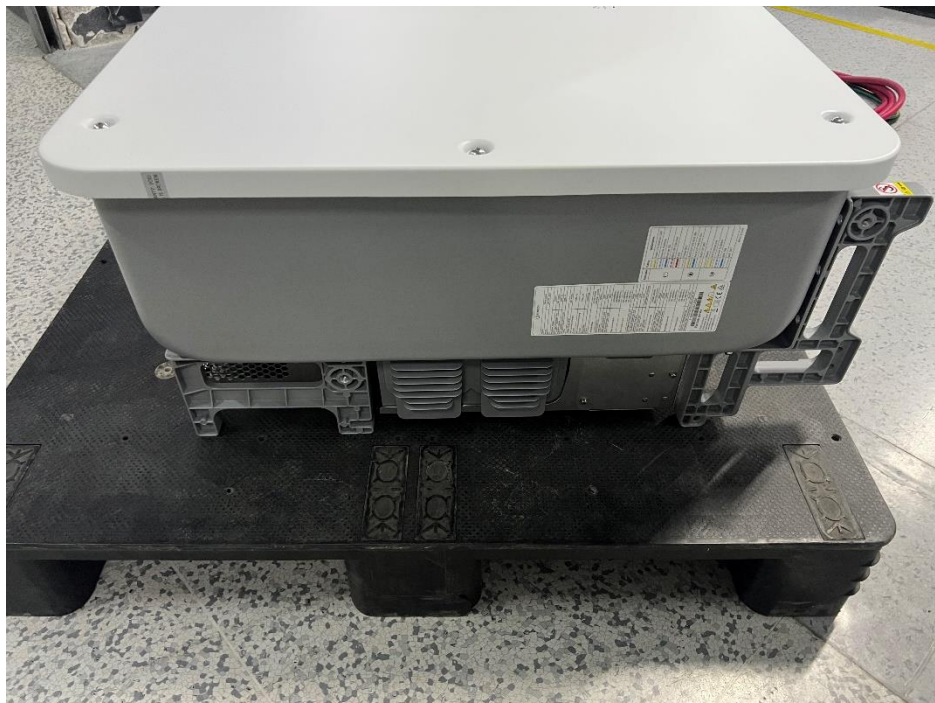

Figure 2 The left side view



Figure 3 The right-side view

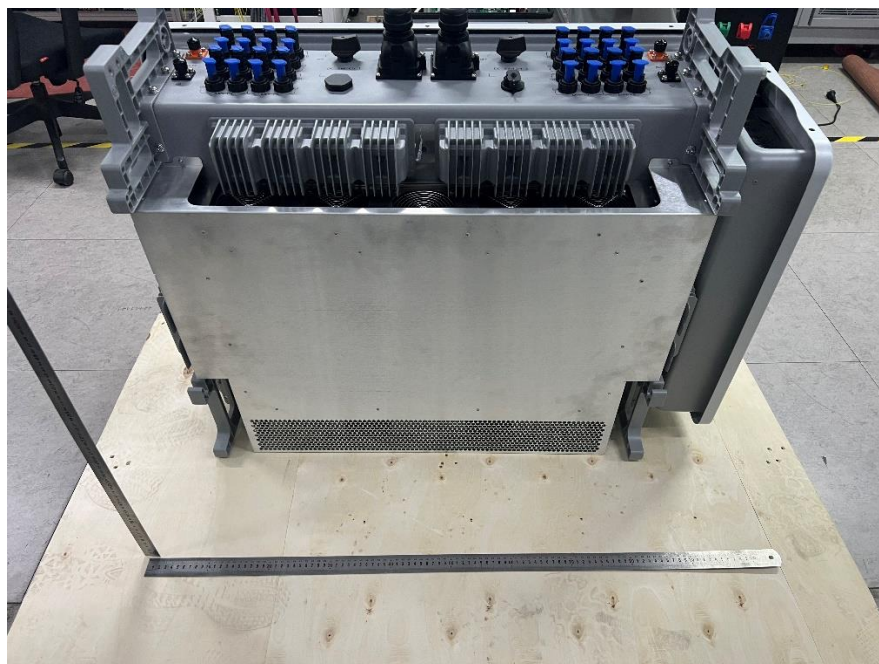

Figure 4 The rear side view

Report Number: CN25J408 002 Attachment 2

Model: See Cover page



Figure 5 The top view

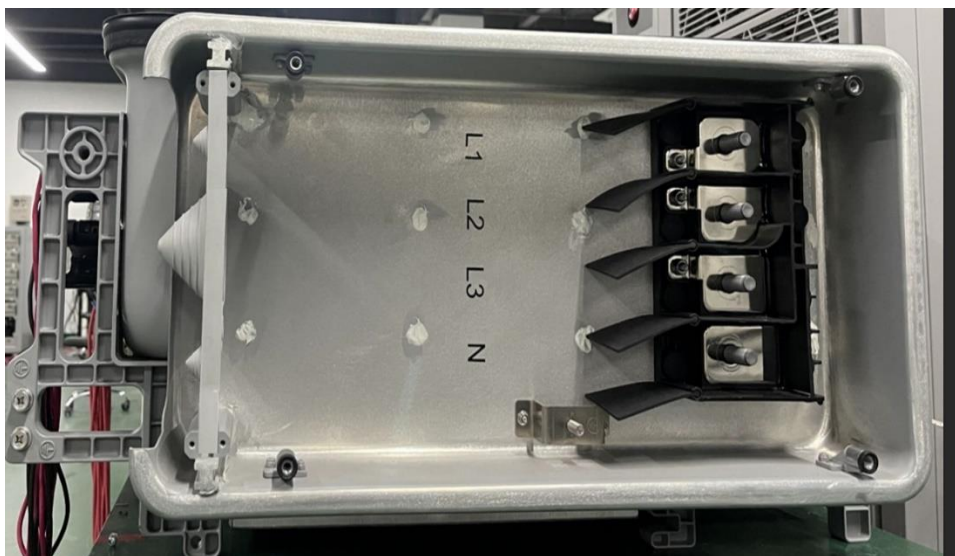

Figure 6 Internal view of AC port without cover

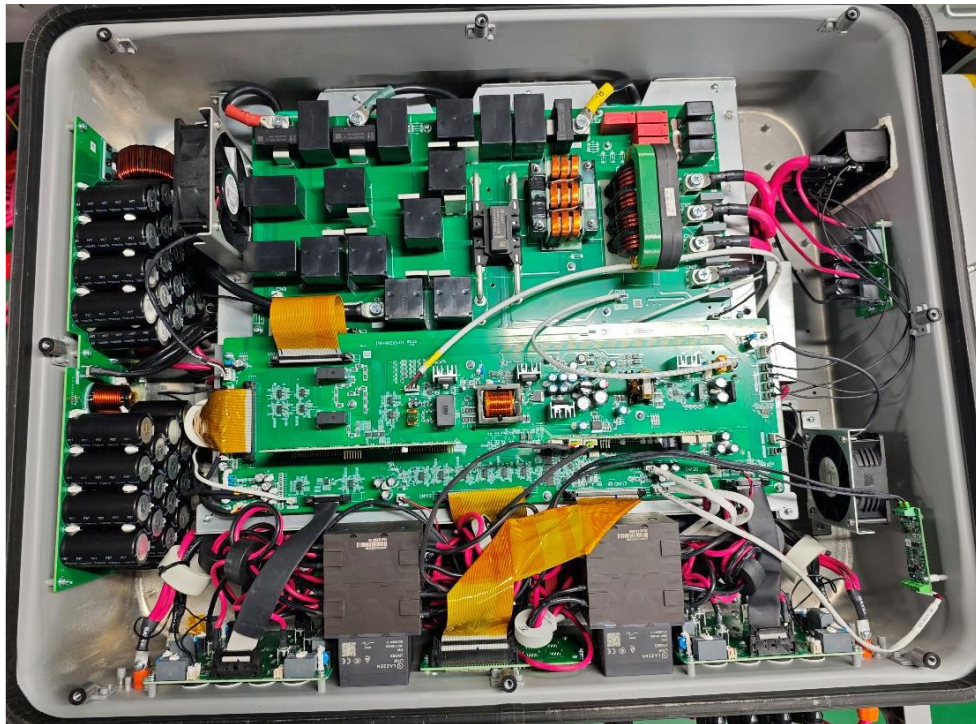

Figure 7 Internal view without cover

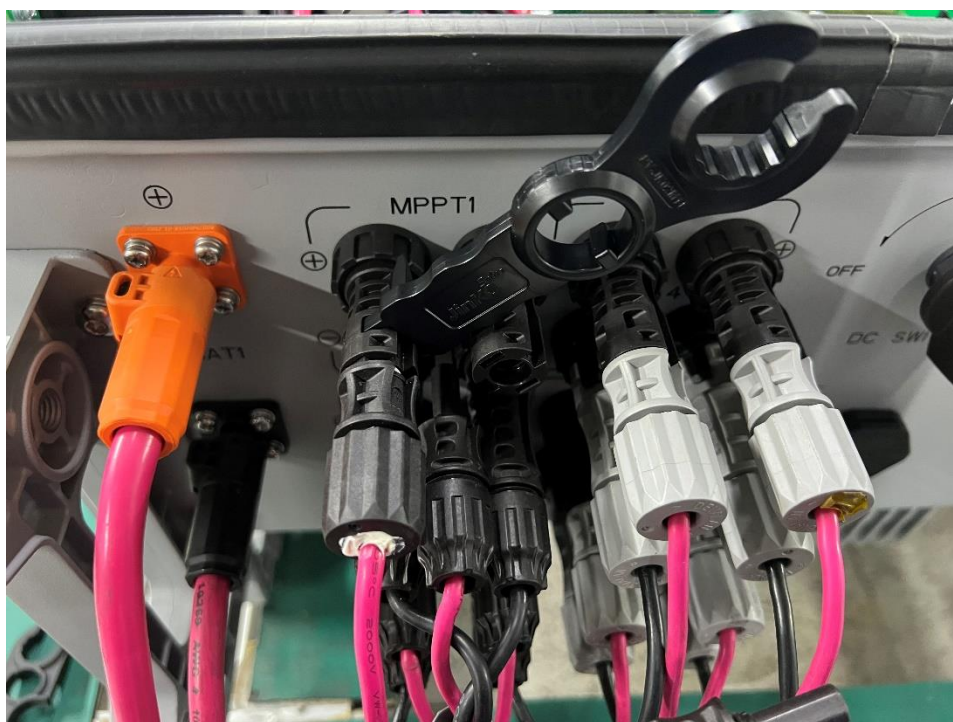

Figure 8 PV connector

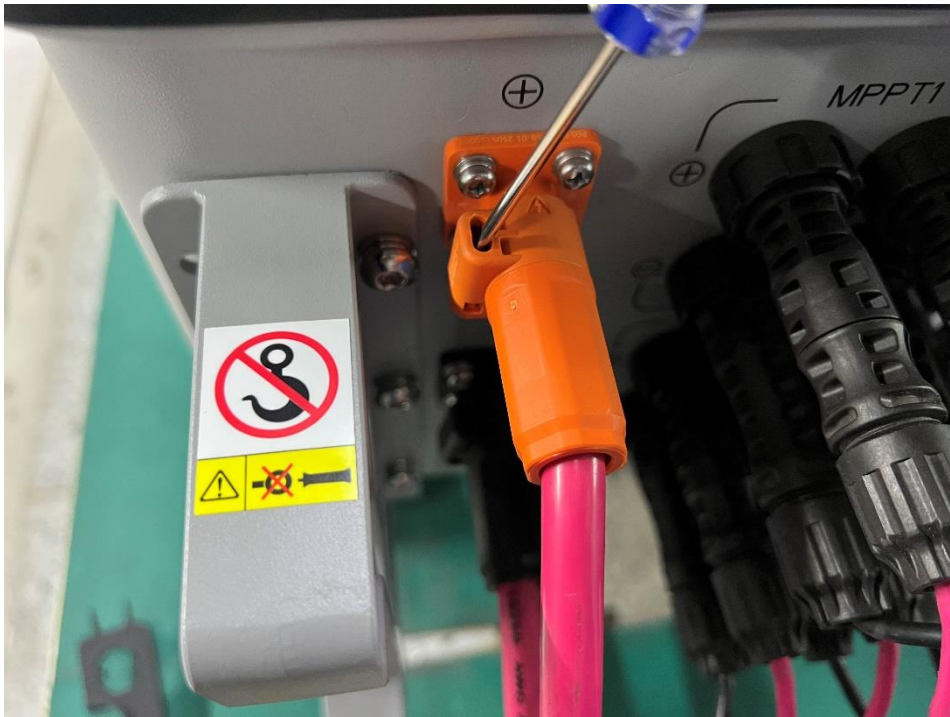

Figure 9 BAT connector

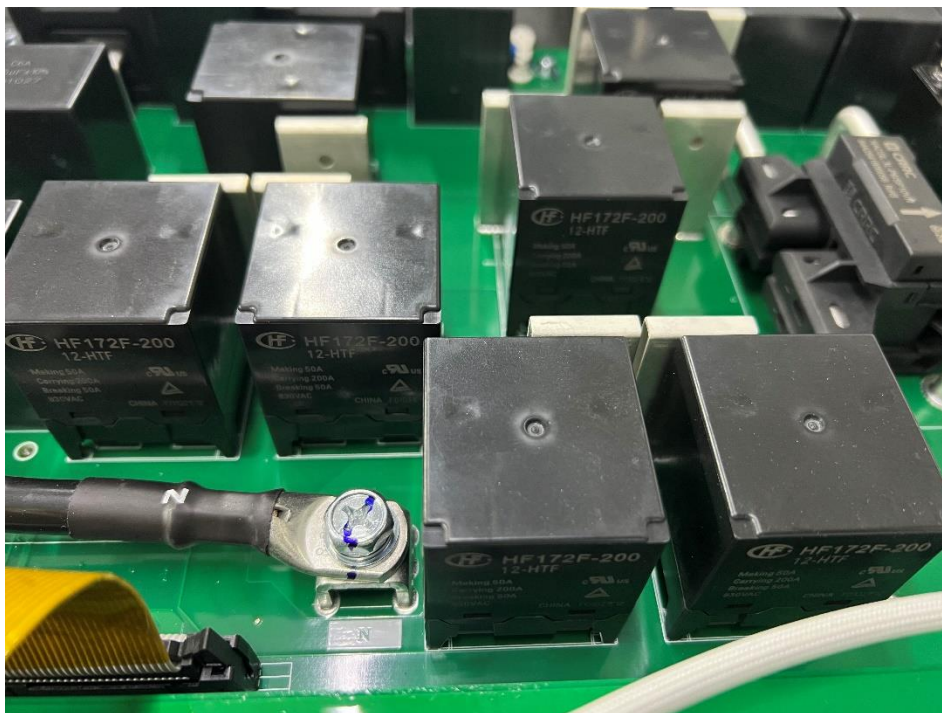

Figure 10 AC relay